

01/09/2021
Evening



Corporate Office: Aakash Tower, 8, Pusa Road, New Delhi-110005 Ph. 011-47623456

Time : 3 hrs.

Answers & Solutions

M.M. : 300

for

JEE (MAIN)-2021 (Online) Phase-4

(Physics, Chemistry and Mathematics)

IMPORTANT INSTRUCTIONS :

- (1) The test is of **3 hours** duration.
- (2) The Test Booklet consists of 90 questions. The maximum marks are 300.
- (3) There are **three** parts in the question paper A, B, C consisting of **Physics, Chemistry and Mathematics** having 30 questions in each part of equal weightage. Each part has two sections.
 - (i) Section-I : This section contains 20 multiple choice questions which have only one correct answer. Each question carries **4 marks** for correct answer and **-1 mark** for wrong answer.
 - (ii) Section-II : This section contains 10 questions. In Section-II, attempt any **five questions out of 10**. There will be **no negative marking for Section-II**. The answer to each of the questions is a numerical value. Each question carries **4 marks** for correct answer and there is no negative marking for wrong answer.

PART-A : PHYSICS

SECTION - I

Multiple Choice Questions: This section contains 20 multiple choice questions. Each question has 4 choices (1), (2), (3) and (4), out of which **ONLY ONE** is correct.

Choose the correct answer :

1. A block of mass m slides on the wooden wedge, which in turn slides backward on the horizontal surface. The acceleration of the block with respect to the wedge is:

Given $m = 8 \text{ kg}$, $M = 16 \text{ kg}$

Assume all the surfaces shown in the figure to be frictionless.

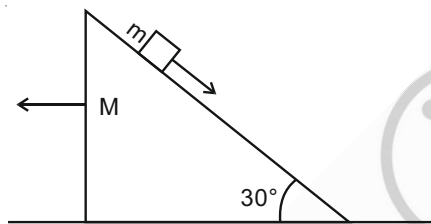

- (1) $\frac{2}{3} g$ (2) $\frac{4}{3} g$
(3) $\frac{6}{5} g$ (4) $\frac{3}{5} g$

Answer (1)

Sol. As, $\sum F_x = 0$
 $\Rightarrow a_{\text{com}} = 0$

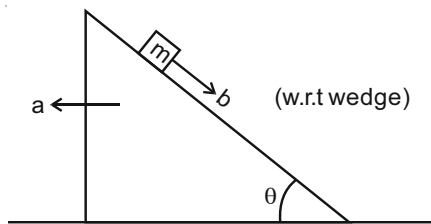

$$\Rightarrow M(-a) + m(b\cos\theta - a) = 0$$

$$\Rightarrow b\cos\theta - a = \frac{M}{m}a$$

$$\Rightarrow b\cos\theta = 3a \quad \dots(i) \quad \text{As } \frac{M}{m} = 2$$

and for block,
 $m\sin\theta + ma\cos\theta = mb$

$$b = g\sin\theta + \frac{b}{3}\cos^2\theta \Rightarrow b\left(1 - \frac{1}{3}\cos^2\theta\right) = g\sin\theta$$

$$\Rightarrow b = \frac{g \times \frac{1}{2}}{1 - \frac{1}{3} \times \frac{3}{4}} = \frac{2}{3} g$$

2. Following plots show Magnetization (M) vs Magnetising field (H) and Magnetic susceptibility χ vs Temperature (T) graph:

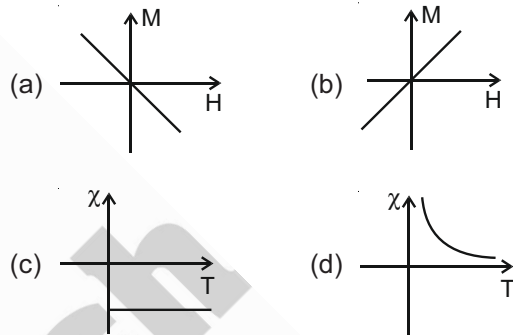

Which of the following combination will be represented by a diamagnetic material?

- (1) (a), (d) (2) (b), (c)
(3) (b), (d) (4) (a), (c)

Answer (4)

Sol. For diamagnetic material

χ is independent of temperature

and magnetisation (M) is directly proportional to H ($M = -CH$)

3. Due to cold weather a 1 m water pipe of cross-sectional area 1 cm^2 is filled with ice at -10°C . Resistive heating is used to melt the ice. Current of 0.5 A is passed through $4 \text{ k}\Omega$ resistance. Assuming that all the heat produced is used for melting, what is the minimum time required?

(Given latent heat of fusion for water/ice = $3.33 \times 10^5 \text{ J kg}^{-1}$, specific heat of ice = $2 \times 10^3 \text{ J kg}^{-1}$ and density of ice = 10^3 kg/m^3)

- (1) 35.3 s (2) 0.353 s
(3) 70.6 s (4) 3.53 s

Answer (1)

Sol. $ms\Delta t + mL = I^2Rt$

$$\Rightarrow 10^3 \times 1 \times 10^{-4} \times 1 [2 \times 10^3 \times 10 + 3.33 \times 10^5]$$

$$= 0.5^2 \times 4 \times 10^3 \times t$$

$$\Rightarrow t = 35.3 \text{ s}$$

4. The temperature of an ideal gas in 3-dimensions is 300 K. The corresponding de-Broglie wavelength of the electron approximately at 300 K, is:

$$[m_e = \text{mass of electron} = 9 \times 10^{-31} \text{ kg}]$$

$$h = \text{Planck constant} = 6.6 \times 10^{-34} \text{ J s}$$

$$k_B = \text{Boltzmann constant} = 1.38 \times 10^{-23} \text{ JK}^{-1}]$$

- (1) 2.26 nm (2) 6.26 nm
(3) 8.46 nm (4) 3.25 nm

Answer (2)

Sol. $\lambda = \frac{h}{\sqrt{2m(\text{K.E.})}}$

$$= \frac{h}{\sqrt{2 \times m \times \frac{3}{2} k_B T}}$$

$$= \frac{6.6 \times 10^{-34}}{\sqrt{9 \times 10^{-31} \times 3 \times 1.38 \times 10^{-23} \times 300}}$$

$$= 0.624 \times 10^{-8} = 6.24 \text{ nm}$$

5. An object of mass 'm' is being moved with a constant velocity under the action of an applied force of 2N along a frictionless surface with following surface profile.

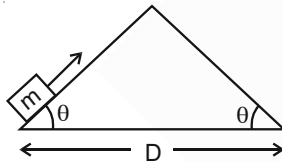

The correct applied force vs distance graph will be:

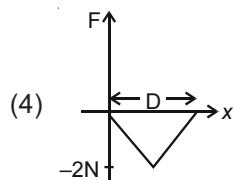
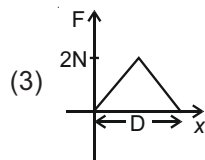
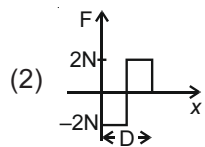
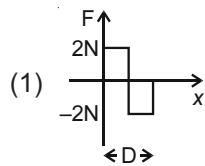

Answer (1)

Sol. In first half,

$$F = mg \sin \theta = 2 \text{ N (upwards along the incline)}$$

In 2nd half,

$$F = mg \sin \theta = 2 \text{ N (upwards along the incline)}$$

6. Four particles each of mass M, move along a circle of radius R under the action of their mutual gravitational attraction as shown in figure. The speed of each particle is:

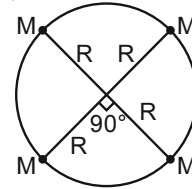

(1) $\frac{1}{2} \sqrt{\frac{GM}{R(2\sqrt{2}+1)}}$

(2) $\frac{1}{2} \sqrt{\frac{GM}{R}(2\sqrt{2}-1)}$

(3) $\sqrt{\frac{GM}{R}}$

(4) $\frac{1}{2} \sqrt{\frac{GM}{R}(2\sqrt{2}+1)}$

Answer (4)

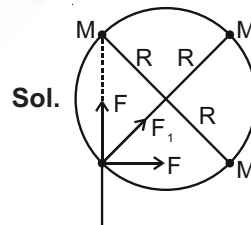

$$F = \frac{GM^2}{(R\sqrt{2})^2}, F_1 = \frac{GM^2}{(2R)^2}$$

$$F_R = (2F \cos 45^\circ + F_1)$$

$$\left(\frac{2F}{\sqrt{2}} + F_1 \right) = \frac{mv^2}{R}$$

$$\Rightarrow v = \frac{1}{2} \sqrt{\frac{GM}{R}(2\sqrt{2}+1)}$$

7. A square loop of side 20 cm and resistance 1Ω is moved towards right with a constant speed v_0 . The right arm of the loop is in a uniform magnetic field of 5 T. The field is perpendicular to the plane of the loop and is going into it. The loop is connected to a network of resistors each of value 4Ω . What should be the value of v_0 so that a steady current of 2 mA flows in the loop?

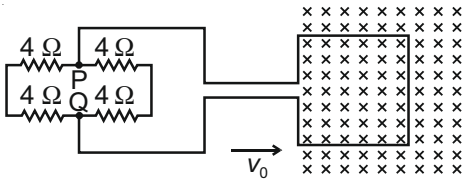

- (1) 1 m/s (2) 10^{-2} cm/s
(3) 1 cm/s (4) 10^2 m/s

Answer (3)

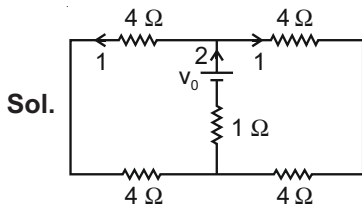

KVL

$$+(2 \times 10^{-3}) \times 1 - v_0 + 8 \times 10^{-3}$$

$$= 0$$

$$\Rightarrow v = 10 \times 10^{-3}$$

$$= 10^{-2} \text{ volts}$$

$$Bvl = v_0$$

$$v = \frac{v_0}{Bl}$$

8. In the given figure, each diode has a forward bias resistance of 30Ω and infinite resistance in reverse bias. The current I_1 will be:

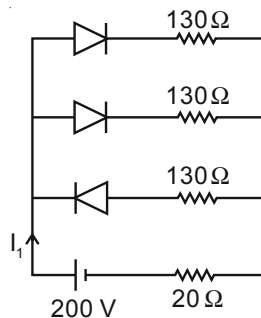

- (1) 2 A (2) 2.35 A
(3) 3.75 A (4) 2.73 A

Answer (1)

Sol. $I_1 = \frac{v}{R_{eq}}$

$$R_{eq} = \frac{200}{100} = 2 \text{ A}$$

9. The half life period of a radioactive element x is same as the mean life time of another radioactive element y. Initially they have the same number of atoms. Then:

- (1) x-will decay faster than y
(2) y-will decay faster than x
(3) x and y decay at the same rate always
(4) x and y have same decay rate initially and later on different decay rate

Answer (2)

Sol. $\frac{-dN}{dt} = \lambda N$

$$\lambda_x = \frac{\ln 2}{t_{1/2}^x}, \quad \lambda_y = \frac{1}{t_{1/2}^y}$$

\Rightarrow y will decay faster, than x

10. A capacitor is connected to a 20 V battery through a resistance of 10Ω . It is found that the potential difference across the capacitor rises to 2 V in 1 μ s. The capacitance of the capacitor is ____ μ F.

Given $\ln\left(\frac{10}{9}\right) = 0.105$

- (1) 0.95 (2) 1.85
(3) 9.52 (4) 0.105

Answer (1)

Sol. $V = \frac{Q}{C}$

$$V = V_0(1 - e^{-t/RC})$$

$$2 = 20 \left(1 - e^{-\frac{10^{-6}}{10C}} \right)$$

$$\Rightarrow C = 0.95 \mu\text{F}$$

11. A body of mass 'm' dropped from a height 'h' reaches the ground with a speed of $0.8 \sqrt{gh}$. The value of work done by the air-friction is:

- (1) mgh (2) 0.64 mgh
(3) 1.64 mgh (4) -0.68 mgh

Answer (4)

Sol. K.E. of particle = $\frac{1}{2}m(0.8\sqrt{gh})^2$
 $= \frac{0.64}{2} mgh$
 $= 0.32 mgh$

So work done by air friction = 0.32 mg – work done by mg = – 0.68 mgh

12. For the given circuit the current i through the battery when the key is closed and the steady state has been reached is _____.

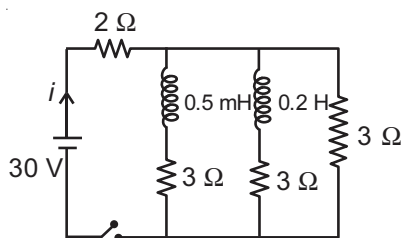

- (1) 6 A (2) 10 A
 (3) 0 A (4) 25 A

Answer (2)

Sol. We know in study state potential difference across inductor = 0

So equivalent circuit is

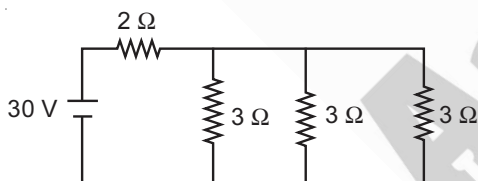

Equivalent resistance across cell = $1 + 2 = 3 \Omega$

So current, $i = \frac{30}{3} = 10 \text{ A}$

13. A glass tumbler having inner depth of 17.5 cm is kept on a table. A student starts pouring water ($\mu = \frac{4}{3}$) into it while looking at the surface of water from the above. When he feels that the tumbler is half filled, he stops pouring water. Up to what height, the tumbler is actually filled?

- (1) 11.7 cm (2) 7.5 cm
 (3) 10 cm (4) 8.75 cm

Answer (3)

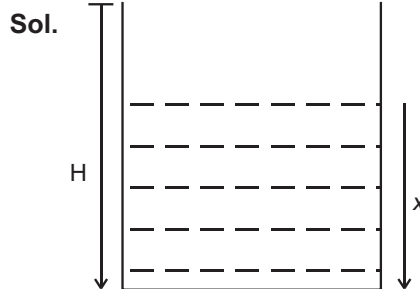

Sol.

$$\frac{x}{\mu} = H - x$$

$$x \left(1 + \frac{1}{\mu}\right) = H$$

$$x = \frac{\mu H}{1 + \mu}$$

$$x = 10 \text{ cm}$$

14. There are two infinitely long straight current carrying conductors and they are held at right angles to each other so that their common ends meet at the origin as shown in the figure given below. The ratio of current in both conductors is 1 : 1. The magnetic field at point P is _____.

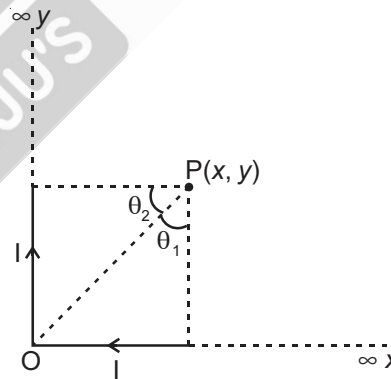

- (1) $\frac{\mu_0 Ixy}{4\pi} \left[\sqrt{x^2 + y^2} + (x + y) \right]$
 (2) $\frac{\mu_0 I}{4\pi xy} \left[\sqrt{x^2 + y^2} + (x + y) \right]$
 (3) $\frac{\mu_0 Ixy}{4\pi} \left[\sqrt{x^2 + y^2} - (x + y) \right]$
 (4) $\frac{\mu_0 I}{4\pi xy} \left[\sqrt{x^2 + y^2} - (x + y) \right]$

Answer (2)

Sol.

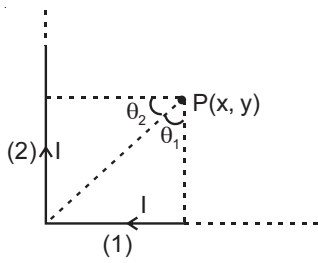

$$\vec{B}_1 = \frac{\mu_0 I}{4\pi y} (\sin\theta_1 + 1)(-\hat{k})$$

$$\vec{B}_2 = \frac{\mu_0 I}{4\pi x} (\sin\theta_2 + 1)(-\hat{k})$$

So, $B_{\text{Net}} = \vec{B}_1 + \vec{B}_2$

$$= \frac{\mu_0 I}{4\pi} \left(\frac{x}{y\sqrt{x^2 + y^2}} + \frac{1}{y} \right) + \frac{\mu_0 I}{4\pi} \left(\frac{1}{x\sqrt{x^2 + y^2}} + \frac{1}{x} \right)$$

$$= \frac{\mu_0 I}{4\pi xy} (\sqrt{x^2 + y^2} + x + y)$$

15. A cube is placed inside an electric field, $\vec{E} = 150y^2\hat{j}$. The side of the cube is 0.5 m and is placed in the field as shown in the given figure. The charge inside the cube is:

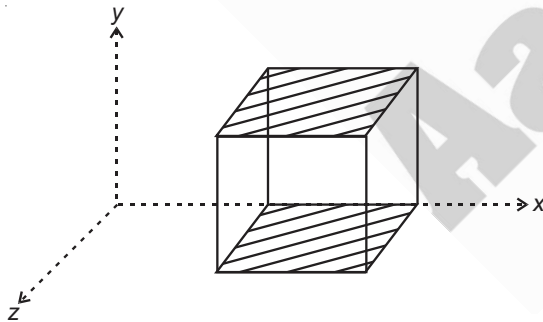

- (1) 8.3×10^{-11} C (2) 3.8×10^{-11} C
(3) 8.3×10^{-12} C (4) 3.8×10^{-12} C

Answer (1)

Sol.

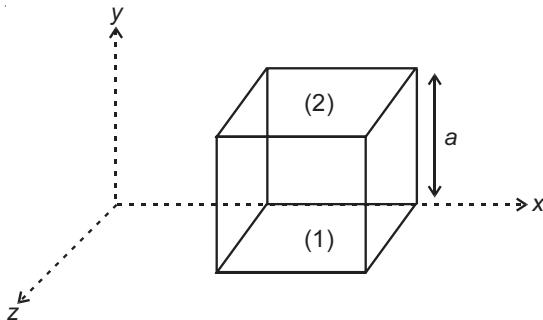

Flux through surface (1) = 0 As electric field is zero

Flux through surface (2) = $150 a^2 \cdot a^2$

$$= 150a^4 = 150 \times \left(\frac{1}{2}\right)^4$$

Flux through other surfaces are zero as electric field is perpendicular to Area vector

Now, using Gauss Law

$$\frac{Q_{\text{in}}}{\epsilon_0} = \phi_{\text{total}} = \frac{150}{16}$$

$$Q_{\text{in}} = \frac{150}{16} \times \epsilon_0$$

$$\approx 8.3 \times 10^{-11} \text{ C}$$

16. The ranges and heights for two projectiles projected with the same initial velocity at angles 42° and 48° with the horizontal are R_1, R_2 and H_1, H_2 respectively. Choose the correct option:

- (1) $R_1 > R_2$ and $H_1 = H_2$
(2) $R_1 < R_2$ and $H_1 < H_2$
(3) $R_1 = R_2$ and $H_1 < H_2$
(4) $R_1 = R_2$ and $H_1 = H_2$

Answer (3)

Sol. $R = \frac{U^2 \sin 2\theta}{g}$

$$H = \frac{U^2 \sin^2 \theta}{2g}$$

$$\theta_1 + \theta_2 = 90$$

$$\Rightarrow R_1 = R_2$$

$$\theta_1 < \theta_2$$

$$\Rightarrow H_1 < H_2$$

17. Electric field of a plane electromagnetic wave propagating through a non-magnetic medium is given by $E = 20\cos(2 \times 10^{10} t - 200x)$ V/m. The dielectric constant of the medium is equal to :

(Take $\mu_r = 1$)

(1) $\frac{1}{3}$ (2) 9

(3) 3 (4) 2

Answer (2)

Sol. Speed of light in medium = $\frac{2 \times 10^{10}}{200}$
 $= 10^8 \text{ m/s}$

$\mu = 3$

$C = \frac{1}{\sqrt{\mu_0 \epsilon_0}}$

$V = \sqrt{\frac{1}{\mu \epsilon}}$

$3 = \sqrt{\frac{\mu \epsilon}{\mu_0 \epsilon_0}}$

⇒ Dielectric constant = 9

18. A student determined Young's Modulus of elasticity

using the formula $Y = \frac{MgL^3}{4bd^3\delta}$. The value of g is taken to be 9.8 m/s², without any significant error, his observation are as following.

Physical Quantity	Least count of the Equipment used for measurement	Observed Value
Mass (M)	1g	2 kg
Length of bar (L)	1mm	1m
Breadth of bar (b)	0.1mm	4 cm
Thickness of bar (d)	0.01mm	0.4 cm
Depression (δ)	0.01mm	5 mm

Then the fractional error in the measurement of Y is :

- (1) 0.155 (2) 0.0083
 (3) 0.0155 (4) 0.083

Answer (3)

Sol. $Y = \frac{MgL^3}{4bd^3\delta}$

$\frac{dY}{Y} = \frac{dM}{M} + \frac{3dL}{L} + \frac{db}{b} + \frac{3dd}{d} + \frac{d\delta}{\delta}$

$= \frac{1}{2000} + \frac{3}{1000} + \frac{1}{400} + \frac{0.003}{0.4} + \frac{1}{500}$

$= \frac{1+6+5.0+15+4}{2000}$

$= \frac{31}{2000} = 0.0155$

19. A mass of 5 kg is connected to a spring. The potential energy curve of the simple harmonic motion executed by the system is shown in the figure. A simple pendulum of length 4 m has the same period of oscillation as the spring system. What is the value of acceleration due to gravity on the planet where these experiments are performed?

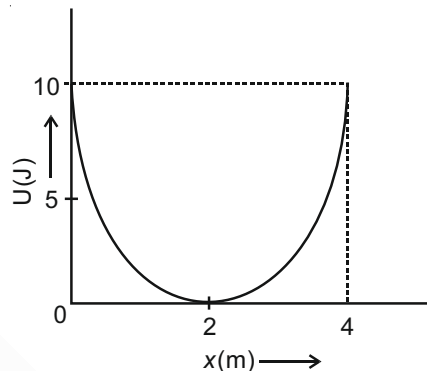

- (1) 9.8 m/s² (2) 4 m/s²
 (3) 10 m/s² (4) 5 m/s²

Answer (2)

Sol. $U = \frac{1}{2}k(x-2)^2$

$\frac{1}{2} \times k \times 4 = 10$

$k = 5$

$\sqrt{\frac{k}{m}} = \sqrt{\frac{g}{l}}$

⇒ $g = 4$

20. Two resistors $R_1 = (4 \pm 0.8) \Omega$ and $R_2 = (4 \pm 0.4) \Omega$ are connected in parallel. The equivalent resistance of their parallel combination will be :

- (1) $(4 \pm 0.4) \Omega$ (2) $(2 \pm 0.4) \Omega$
 (3) $(2 \pm 0.3) \Omega$ (4) $(4 \pm 0.3) \Omega$

Answer (3)

Sol. $\frac{1}{R} = \frac{1}{R_1} + \frac{1}{R_2}$... (1)

$-\frac{dR}{R^2} = -\frac{dR_1}{R_1^2} - \frac{dR_2}{R_2^2}$... (2)

From (1) $R = 2 \Omega$

$+\frac{dR}{4} = \frac{0.8}{16} + \frac{0.4}{16}$

$dR = \frac{4.8}{16} = 0.3$

SECTION - II

Numerical Value Type Questions: This section contains 10 questions. In Section II, attempt any five questions out of 10. The answer to each question is a **NUMERICAL VALUE**. For each question, enter the correct numerical value (in decimal notation, truncated/rounded-off to the second decimal place; e.g. 06.25, 07.00, -00.33, -00.30, 30.27, -27.30) using the mouse and the on-screen virtual numeric keypad in the place designated to enter the answer.

1. A uniform heating wire of resistance 36Ω is connected across a potential difference of 240 V. The wire is then cut into half and a potential difference of 240 V is applied across each half separately. The ratio of power dissipation in first case to the total power dissipation in the second case would be 1: x, where x is _____.

Answer (4)

Sol. $P_1 = \frac{V^2}{R}$

$$P_2 = \frac{V^2}{R/2} \times 2 = 4 \frac{V^2}{R}$$

$$\frac{P_1}{P_2} = \frac{1}{4}$$

2. An engine is attached to a wagon through a shock absorber of length 1.5 m. The system with a total mass of 40,000 kg is moving with a speed of 72 kmh^{-1} when the brakes are applied to bring it to rest. In the process of the system being brought to rest, the spring of the shock absorber gets compressed by 1.0 m. If 90% of energy of the wagon is lost due to friction, the spring constant is _____ $\times 10^5 \text{ N/m}$.

Answer (16)

Sol. $-\frac{1}{2} \cdot kx^2 + W_f = 0 - \frac{1}{2}Mv^2$

$$\frac{1}{2}k(1)^2 = (1-0.9)\frac{1}{2}Mv^2$$

$$k = 0.1 \times 40000 \times (20)^2 = 16 \times 10^5 \text{ N/m}$$

3. A steel rod with $y = 2.0 \times 10^{11} \text{ Nm}^{-2}$ and $\alpha = 10^{-5} \text{ }^\circ\text{C}^{-1}$ of length 4 m and area of cross-section 10 cm^2 is heated from 0°C to 400°C without being allowed to extend. The tension produced in the rod $x \times 10^5 \text{ N}$ where the value of x is _____.

Answer (8)

Sol. $F = Y \alpha \Delta\theta \cdot A$
 $= 2 \times 10^{11} \times 10^{-5} \times 400 \times 10 \times 10^{-4}$
 $= 8 \times 10^5 \text{ N}$

4. The width of one of the two slits in a Young's double slit experiment is three times the other slit. If the amplitude of the light coming from a slit is proportional to the slit-width, the ratio of minimum to maximum intensity in the interference pattern is $x : 4$ where x is _____.

Answer (1)

Sol. $\frac{I_{\min}}{I_{\max}} = \left(\frac{A_1 - A_2}{A_1 + A_2}\right)^2 = \left(\frac{3-1}{3+1}\right)^2 = \frac{1}{4}$

5. A carrier wave with amplitude of 250 V is amplitude modulated by a sinusoidal base band signal of amplitude 150 V. The ratio of minimum amplitude to maximum amplitude for the amplitude modulated wave is $50 : x$, then value of x is _____.

Answer (200)

Sol. $\frac{V_c - V_m}{V_c + V_m} = \frac{250 - 150}{250 + 150} = \frac{1}{4}$

6. The average translational kinetic energy of N_2 gas molecules at _____ $^\circ\text{C}$ becomes equal to the K.E. of an electron accelerated from rest through a potential difference of 0.1 volt. (Given $k_B = 1.38 \times 10^{-23} \text{ J/K}$) (Fill the nearest integer).

Answer (500)

Sol. $3 \times \frac{1}{2} k_B T = (1.6 \times 10^{-19}) (0.1) \cong 773 \text{ K} = 500^\circ\text{C}$

7. When a body slides down from rest along a smooth inclined plane making an angle of 30° with the horizontal, it takes time T. When the same body slides down from the rest along a rough inclined plane making the same angle and through the same distance, it takes time αT , where α is a constant greater than 1. The co-efficient of friction between

the body and the rough plane is $\frac{1}{\sqrt{x}} \left(\frac{\alpha^2 - 1}{\alpha^2} \right)$ where

x = _____.

Answer (3)

Sol. $\frac{T}{\alpha T} = \sqrt{\frac{a_{\text{rough}}}{a_{\text{smooth}}}}$
 $= \sqrt{\frac{1 - \mu\sqrt{3}}{\frac{2}{1/2}}}$

$$1 - \sqrt{3}\mu = \frac{1}{\alpha^2}$$

$$\mu = \frac{1}{\sqrt{3}} \left(\frac{\alpha^2 - 1}{\alpha^2} \right)$$

8. The temperature of 3.00 mol of an ideal diatomic gas is increased by 40.0°C without changing the pressure of the gas. The molecules in the gas rotate but do not oscillate. If the ratio of change in internal energy of the gas to the amount of workdone by the gas is $\frac{x}{10}$. Then the value of x (round off to the nearest integer) is _____.
 (Given R = 8.31 J mol⁻¹ K⁻¹)

Answer (25)

Sol. d.o.f = 5

For isobaric process polytropic coefficient = n = 0

$$\frac{\Delta U}{W} = \frac{1-n}{\gamma-1}$$

$$= \frac{1}{2} = \frac{5}{2} = \frac{25}{10}$$

$$\frac{1}{f}$$

9. Two satellites revolve around a planet in coplanar circular orbits in anticlockwise direction. Their period of revolutions are 1 hour and 8 hours respectively. The radius of the orbit of nearer satellite is 2×10^3 km. The angular speed of the farther satellite as observed from the nearer satellite at the instant when both the satellites are closest is $\frac{\pi}{x}$ rad h⁻¹ where x is _____.

Answer (3)

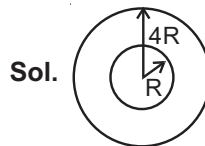

$$\omega = \frac{v_{\text{rel}}}{r_{\text{rel}}}$$

$$= \frac{2\pi\left(\frac{R}{T}\right) - 2\pi\left(\frac{4R}{8T}\right)}{3R}$$

$$\omega = \frac{\pi}{3T}$$

$$\omega = \frac{\pi}{3} \text{ rad h}^{-1}$$

10. A 2 kg steel rod of length 0.6 m is clamped on a table vertically at its lower end and is free to rotate in vertical plane. The upper end is pushed so that the rod falls under gravity. Ignoring the friction due to clamping at its lower end, the speed of the free end of rod when it passes through its lowest position is _____ ms⁻¹.
 (Take g = 10 ms⁻²)

Answer (6)

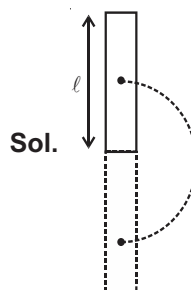

$$\frac{1}{2} \left(\frac{ml^2}{3} \right) \omega^2 = mgl$$

$$\Rightarrow \omega l = \sqrt{6gl} = 6 \text{ m/s}$$

PART-B : CHEMISTRY

SECTION - I

Multiple Choice Questions: This section contains 20 multiple choice questions. Each question has 4 choices (1), (2), (3) and (4), out of which **ONLY ONE** is correct.

Choose the correct answer :

1. Identify the element for which electronic configuration in +3 oxidation state is $[Ar]3d^5$:

- (1) Mn (2) Ru
(3) Co (4) Fe

Answer (4)

Sol. $Mn(25) = [Ar]3d^54s^2$



Ru-belong to 4d transition series

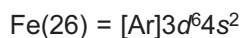
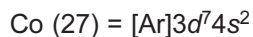

2. The oxide **without** nitrogen-nitrogen bond is :

- (1) N_2O_5 (2) N_2O_3
(3) N_2O_4 (4) N_2O

Answer (1)

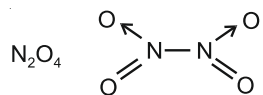
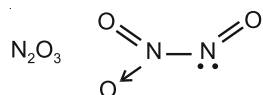
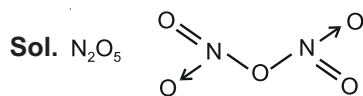

3. Experimentally reducing a functional group **cannot** be done by which one of the following reagents ?

- (1) Pd-C/ H_2 (2) Pt-C/ H_2
(3) Zn/ H_2O (4) Na/ H_2

Answer (4)

Sol. • Na in presence of H_2 , will not release electron which are required for reduction.

• H_2 gas also not get adsorbed on Na. Hence Na/ H_2 cannot be used as a reducing agent

4. Water sample is called cleanest on the basis of which one of the BOD values given below :

- (1) 3 ppm
(2) 21 ppm
(3) 15 ppm
(4) 11 ppm

Answer (1)

Sol. Lesser the value of BOD, cleaner will be the water sample

5. Which one of the following gives the most stable Diazonium salt?

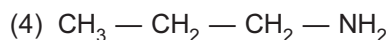
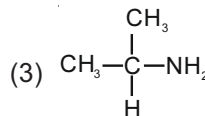
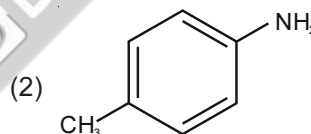

Answer (2)

Sol. 1° aromatic amines give the most stable diazonium salt

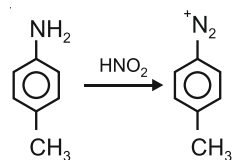

6. In the following sequence of reactions a compound A, (molecular formula $C_6H_{12}O_2$) with a straight chain structure gives a C_4 carboxylic acid. A is :

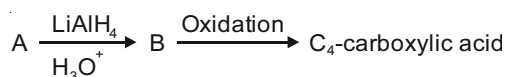

- (1) $CH_3 - CH_2 - COO - CH_2 - CH_2 - CH_3$
 (2) $CH_3 - CH_2 - CH_2 - O - CH = CH - CH_2 - OH$
 (3) $CH_3 - CH_2 - CH_2 - COO - CH_2 = CH_3$

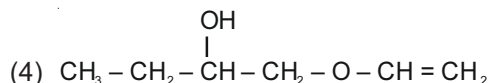

Answer (3)

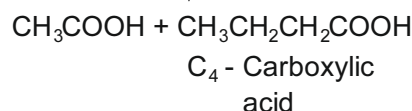
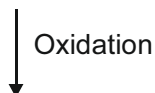
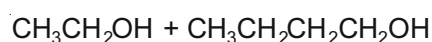
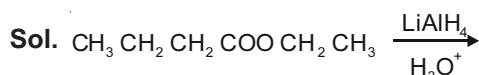

7. In the given chemical reaction colors of the Fe^{2+} and Fe^{3+} ions, are respectively :

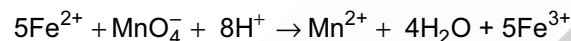

- (1) Yellow, Green (2) Green, Orange
 (3) Green, Yellow (4) Yellow, Orange

Answer (3)

Sol. Fe^{2+} is green in color
 Fe^{3+} is yellow in color

8. Which one of the following compounds is aromatic in nature?

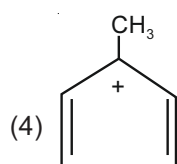
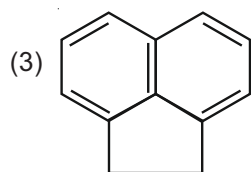
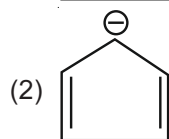
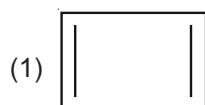

Answer (2 and 3, Bonus)

Sol. Compounds that are planar and that have $(4n + 2)$ πe^- are aromatic.

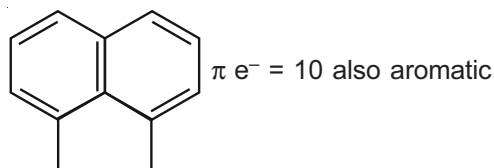
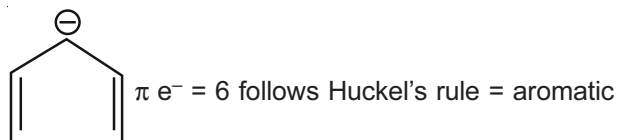

9. Calamine and Malachite, respectively, are the ores of :

- (1) Nickel and Aluminium
 (2) Aluminium and Zinc
 (3) Zinc and Copper
 (4) Copper and Iron

Answer (3)

Sol. Calamine is $ZnCO_3$, ore of Zinc
 Malachite is $CuCO_3 \cdot Cu(OH)_2$, ore of Cu.

10. In the following sequence of reactions,

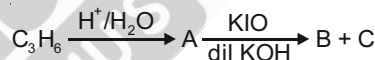

The compounds B and C respectively are :

- (1) Cl_3COOK , $HCOOH$
 (2) CHI_3 , CH_3COOK
 (3) Cl_3COOK , CH_3I
 (4) CH_3I , $HCOOK$

Answer (2)

Sol.

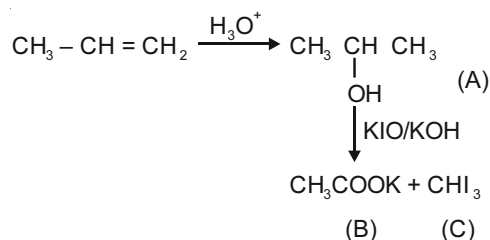

11. The stereoisomers that are formed by electrophilic addition of bromine to *trans*-but-2-ene is/are :

- (1) 1 racemic and 2 enantiomers
 (2) 2 identical mesomers
 (3) 2 enantiomers
 (4) 2 enantiomers and 2 mesomers

Answer (2)

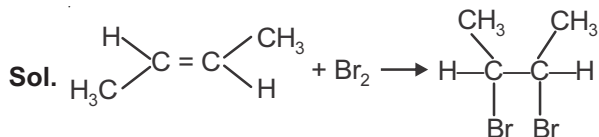

anti-addition on trans 2-butene will form mesomer

12. The potassium ferrocyanide solution gives a Prussian blue colour, when added to :

- (1) CoCl_3
- (2) CoCl_2
- (3) FeCl_2
- (4) FeCl_3

Answer (4)

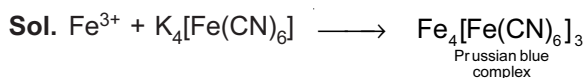

13. The Crystal Field Stabilization Energy (CFSE) and magnetic moment (spin-only) of an octahedral aqua complex of a metal ion (M^{2+}) are $-0.8 \Delta_0$ and 3.87 BM, respectively. Identify (M^{2+}) :

- (1) Cr^{3+}
- (2) V^{3+}
- (3) Mn^{4+}
- (4) Co^{2+}

Answer (4)

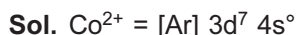

in $[\text{Co}(\text{H}_2\text{O})_6]^{2+}$, H_2O will behave as weak field ligand

$$\text{Co}^{2+} = t_2g^5, e_g^2$$

$$\text{CFSE} = (-0.4 \times 5 + 2 \times 0.6) \Delta_0$$

$$= -0.8 \Delta_0$$

Co^{2+} has 3 unpaired e^- , $\mu = 3.87 \text{ BM}$

14. Which one of the following given graphs represents the variation of rate constant (k) with temperature (T) for an endothermic reaction?

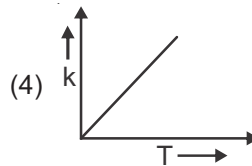
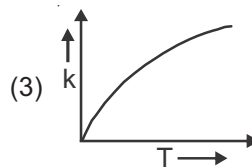
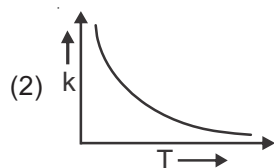
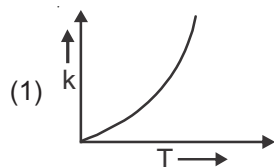

Answer (1)

Sol. According to Arrhenius equation

$$K = A e^{-E_a/RT}$$

The graph will varies as

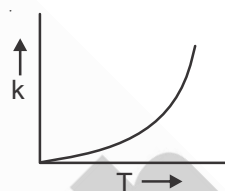

15. Monomer units of Dacron polymer are

- (1) Glycerol and phthalic acid
- (2) Glycerol and terephthalic acid
- (3) Ethylene glycol and phthalic acid
- (4) Ethylene glycol and terephthalic acid

Answer (4)

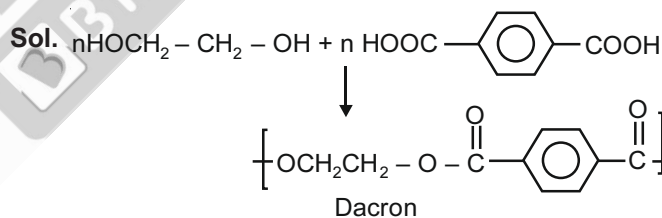

16. Given below are two statements:

Statement I : The nucleophilic addition of sodium hydrogen sulphite to an aldehyde or a ketone involves proton transfer to form a stable ion.

Statement II : The nucleophilic addition of hydrogen cyanide to an aldehyde or a ketone yields amine as final product.

In the light of the above statements, choose the most appropriate answer from the options given below:

- (1) Statement I is true but Statement II is false
- (2) Statement I is false but Statement II is true
- (3) Both Statement I and Statement II are true
- (4) Both Statement I and Statement II are false

Answer (1)

Sol.

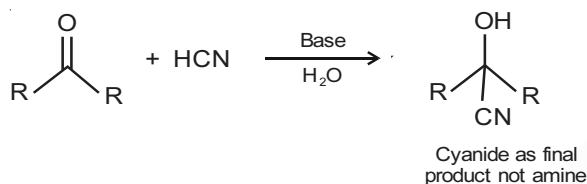
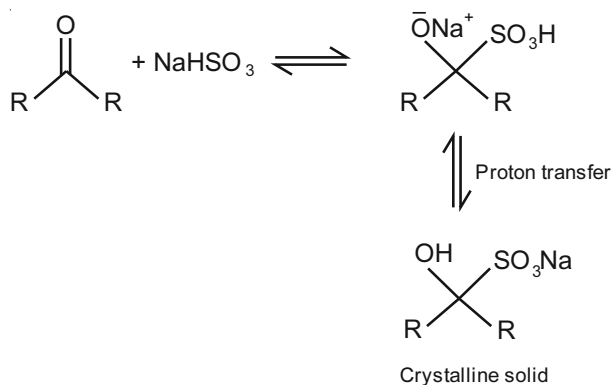

17. Number of paramagnetic oxides among the following given oxides is _____.

Li_2O , CaO , Na_2O_2 , KO_2 , MgO and K_2O

- (1) 3
- (2) 2
- (3) 1
- (4) 0

Answer (3)

Sol. Oxides

	Magnetic nature
Li_2O	Diamagnetic
CaO	Diamagnetic
Na_2O_2	Diamagnetic
KO_2	Paramagnetic
MgO	Diamagnetic
K_2O	Diamagnetic

18. Hydrogen peroxide reacts with iodine in basic medium to give

- (1) IO_3^-
- (2) IO^-
- (3) I^-
- (4) IO_4^-

Answer (3)

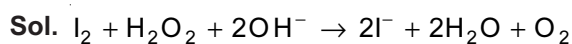

19. Identify A in the following reaction.

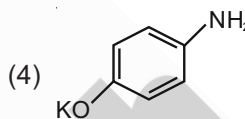
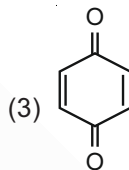
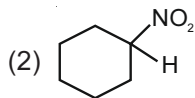
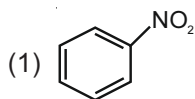
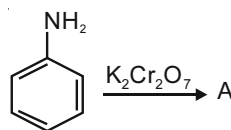

Answer (3)

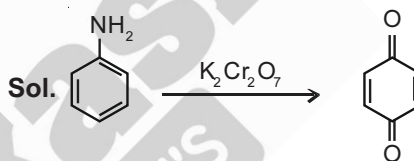

$\text{K}_2\text{Cr}_2\text{O}_7$ is oxidizing agent.

20. Match List-I with List-II.

List-I (Colloid Preparation Method)	List-II (Chemical Reaction)
(a) Hydrolysis	(i) $2\text{AuCl}_3 + 3\text{HCHO} + 3\text{H}_2\text{O} \rightarrow 2\text{Au(sol)} + 3\text{HCOOH} + 6\text{HCl}$
(b) Reduction	(ii) $\text{As}_2\text{O}_3 + 3\text{H}_2\text{S} \rightarrow \text{As}_2\text{S}_3(\text{sol}) + 3\text{H}_2\text{O}$
(c) Oxidation	(iii) $\text{SO}_2 + 2\text{H}_2\text{S} \rightarrow 3\text{S(sol)} + 2\text{H}_2\text{O}$
(d) Double Decomposition	(iv) $\text{FeCl}_3 + 3\text{H}_2\text{O} \rightarrow \text{Fe(OH)}_3(\text{sol}) + 3\text{HCl}$

Choose the **most appropriate** answer from the options given below

- (1) (a)-(iv), (b)-(ii), (c)-(iii), (d)-(i)
- (2) (a)-(i), (b)-(ii), (c)-(iv), (d)-(iii)
- (3) (a)-(i), (b)-(iii), (c)-(ii), (d)-(iv)
- (4) (a)-(iv), (b)-(i), (c)-(iii), (d)-(ii)

Answer (4)

Sol. In reaction (i), Au (sol) is formed by reduction of AuCl_3 , so the chemical method of preparation is "Reduction".

In reaction (ii), As_2S_3 (sol) is formed by double decomposition, so the chemical method of preparation is "Double decomposition".

In reaction (iii), S (sol) is formed by oxidation of H_2S , so the chemical method of preparation is "Oxidation".

In reaction (iv), $\text{Fe}(\text{OH})_3$ (sol) is formed by hydrolysis of FeCl_3 so the chemical method of preparation is "Hydrolysis".

SECTION - II

Numerical Value Type Questions: This section contains 10 questions. In Section II, attempt any five questions out of 10. The answer to each question is a **NUMERICAL VALUE**. For each question, enter the correct numerical value (in decimal notation, truncated/rounded-off to the second decimal place; e.g. 06.25, 07.00, -00.33, -00.30, 30.27, -27.30) using the mouse and the on-screen virtual numeric keypad in the place designated to enter the answer.

1. A 50 watt bulb emits monochromatic red light of wavelength of 795 nm. The number of photons emitted per second by the bulb is $x \times 10^{20}$. The value of x is _____. (Nearest integer)

[Given : $h = 6.63 \times 10^{-34}$ Js and $c = 3.0 \times 10^8$ ms^{-1}]

Answer (2)

Sol. $E = nh\nu$

50 watt bulb emits 50 J energy per second.

$$50 = \frac{n \times 6.63 \times 10^{-34} \times 3 \times 10^8}{795 \times 10^{-9}}$$

$$n = \frac{50 \times 795 \times 10^{-9}}{6.63 \times 10^{-34} \times 3 \times 10^8}$$

$$n \approx 2 \times 10^{20}$$

2. If 80 g of copper sulphate $\text{CuSO}_4 \cdot 5\text{H}_2\text{O}$ is dissolved in deionised water to make 5 L of solution. The concentration of the copper sulphate solution is $x \times 10^{-3}$ mol L^{-1} . The value of x is _____.

[Atomic masses Cu : 63.54 u, S : 32 u, O : 16 u, H : 1 u]

Answer (64)

Sol. $M = \frac{\text{moles of solute}}{\text{volume of solution in L}}$

$$M = \frac{80}{249.54 \times 5} \approx 64 \times 10^{-3} \text{ mol L}^{-1}$$

3. An empty LPG cylinder weighs 14.8 kg. When full, it weighs 29.0 kg and shows a pressure of 3.47 atm. In the course of use at ambient temperature, the mass of the cylinder is reduced to 23.0 kg. The final pressure inside the cylinder is _____ atm. (Nearest integer)

(Assume LPG to be an ideal gas)

Answer (2)

Sol. Initial amount of gas present in the cylinder

$$= (29.0 - 14.8)$$

$$= 14.2 \text{ kg}$$

Final amount of gas present in the cylinder

$$= (23.0 - 14.8)$$

$$= 8.2 \text{ kg}$$

$$\frac{P_1}{n_1} = \frac{P_2}{n_2}$$

$$P_2 = n_2 \times \frac{P_1}{n_1} = \frac{8200}{M.wt} \times \frac{3.47 \times M.wt}{14200}$$

$$P_2 = 2 \text{ atm}$$

4. The sum of oxidation states of two silver ions in $[\text{Ag}(\text{NH}_3)_2][\text{Ag}(\text{CN})_2]$ complex is _____.

Answer (2)

Sol. $[\text{Ag}(\text{NH}_3)_2]^+ [\text{Ag}(\text{CN})_2]^-$

Oxidation state of Ag in both ions is +1.

5. For the reaction $2\text{NO}_2(\text{g}) \rightleftharpoons \text{N}_2\text{O}_4(\text{g})$, when $\Delta S = -176.0 \text{ J K}^{-1}$ and $\Delta H = -57.8 \text{ kJ mol}^{-1}$, the magnitude of ΔG at 298 K for the reaction is _____ kJ mol^{-1} . (Nearest integer)

Answer (5)

Sol. $\Delta G = \Delta H - T\Delta S$

$$\Delta G = -57.8 + 298 \times 176 \times 10^{-3}$$

$$\Delta G \approx -5 \text{ kJ mol}^{-1}$$

6. The number of atoms in 8 g of sodium is $x \times 10^{23}$. The value of x is _____. (Nearest integer)

[Given : $N_A = 6.02 \times 10^{23} \text{ mol}^{-1}$

Atomic mass of Na = 23.0 u]

Answer (2)

Sol. Moles = $\frac{\text{Number of atom}}{\text{Avogadro's number}}$

$$\text{Moles} = \frac{\text{Given mass}}{\text{Molar mass}}$$

$$\frac{8}{23} = \frac{\text{Number of atoms}}{6.02 \times 10^{23}}$$

Number of atoms = 2×10^{23}

7. If the conductivity of mercury at 0°C is $1.07 \times 10^6 \text{ S m}^{-1}$ and the resistance of a cell containing mercury is 0.243Ω , then the cell constant of the cell is $x \times 10^4 \text{ m}^{-1}$. The value of x is _____. (Nearest integer)

Answer (26)

Sol. $\kappa = \frac{1}{R} \times (\text{Cell constant})$

$$1.07 \times 10^6 \text{ S m}^{-1} = \frac{1}{0.243} \times (\text{Cell constant})$$

Cell constant = 26×10^4

8. The spin-only magnetic moment value of B_2^+ species is _____ $\times 10^{-2} \text{ BM}$. (Nearest integer)

[Given : $\sqrt{3} = 1.73$]

Answer (173)

Sol. According to MOT, electronic configuration of B_2^+ is

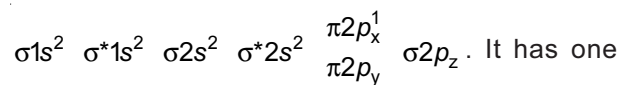

It has one unpaired electron.

(μ) Spin - only magnetic moment = $\sqrt{n(n+2)}$ B.M.

n = Number of unpaired electrons

$$\mu = \sqrt{1(1+2)} \text{ B.M.}$$

$$\mu = 1.73 \text{ B.M.}$$

$$\mu = 173 \times 10^{-2} \text{ B.M.}$$

9. A peptide synthesized by the reactions of one molecule each of Glycine, Leucine, Aspartic acid and Histidine will have _____ peptide linkages.

Answer (3)

Sol. Combination of n amino acids gives a polypeptide with $(n - 1)$ peptide linkages.

Similarly combination of four amino acids gives a tetrapeptide with three peptide linkages.

10. The molar solubility of $Zn(OH)_2$ in 0.1 M NaOH solution is $x \times 10^{-18} \text{ M}$. The value of x is _____. (Nearest integer)

(Given : The solubility product of $Zn(OH)_2$ is 2×10^{-20})

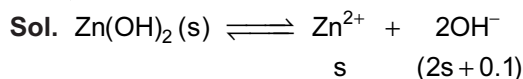
Answer (2)

$$K_{sp} = [Zn^{2+}][OH^-]^2$$

$$2 \times 10^{-20} = (s)(2s + 0.1)^2$$

Neglecting $2s$ w.r.t. 0.1 gives $s = 2 \times 10^{-18} \text{ M}$

So value of x is 2

PART-C : MATHEMATICS

SECTION - I

Multiple Choice Questions: This section contains 20 multiple choice questions. Each question has 4 choices (1), (2), (3) and (4), out of which **ONLY ONE** is correct.

Choose the correct answer :

1. Let the acute angle bisector of the two planes $x - 2y - 2z + 1$ and $2x - 3y - 6z + 1 = 0$ be the plane P . Then which of the following points lies on P ?

- (1) $\left(-2, 0, -\frac{1}{2}\right)$
- (2) $(0, 2, -4)$
- (3) $(4, 0, -2)$
- (4) $\left(3, 1, -\frac{1}{2}\right)$

Answer (1)

Sol. $P_1 \equiv x - 2y - 2z + 1 = 0$; $P_2 \equiv 2x - 3y - 6z + 1 = 0$

Pair of bisectors be

$$\frac{x - 2y - 2z + 1}{3} = \pm \frac{2x - 3y - 6z + 1}{7}$$

$$\text{As } a_1a_2 + b_1b_2 + c_1c_2 = 1(2) + (-2)(-3) + (-2)(-6) > 0$$

Ogive sign gives acute angle bisector

$$\text{i.e., } 7(x - 2y - 2z + 1) = -3(2x - 3y - 6z + 1)$$

$$\Rightarrow 13x - 23y - 32z + 10 = 0$$

Clearly $(-2, 0, -1/2)$ satisfy above plane.

2. $\cos^{-1}(\cos(-5)) + \sin^{-1}(\sin(6)) - \tan^{-1}(\tan(12))$

is equal to (The inverse trigonometric functions take the principal values)

- (1) $3\pi + 1$
- (2) $3\pi - 11$
- (3) $4\pi - 11$
- (4) $4\pi - 9$

Answer (3)

Sol. $\cos^{-1}(\cos(-5)) = -5 + 2\pi = a$ (say)

$$\sin^{-1}(\sin 6) = 6 - 2\pi = b$$
 (say)

$$\tan^{-1}(\tan 12) = 12 - 4\pi = c$$
 (say)

$$\therefore a + b - c = 2\pi - 5 + 6 - 2\pi - 12 + 4\pi = 4\pi - 11$$

3. Consider the system of linear equations

$$-x + y + 2z = 0$$

$$3x - ay + 5z = 1$$

$$2x - 2y - az = 7$$

Let S_1 be the set of all $a \in \mathbf{R}$ for which system is inconsistent and S_2 be the set of all $a \in \mathbf{R}$ for which the system has infinitely many solutions. If $n(S_1)$ and $n(S_2)$ denote the number of elements in S_1 and S_2 respectively, then

- (1) $n(S_1) = 2, n(S_2) = 0$
- (2) $n(S_1) = 1, n(S_2) = 0$
- (3) $n(S_1) = 2, n(S_2) = 2$
- (4) $n(S_1) = 0, n(S_2) = 2$

Answer (3)

Sol. Given $-x + y + 2z = 0 \Rightarrow x = y + 2z$

$$\therefore 3y + 6z - ay + 5z = 1 \dots(i)$$

$$2y + 4z - 2y - az = 7 \dots(ii)$$

$$(3 - a)y + 11z = 1 \dots(iii)$$

$$\text{and } z = \frac{7}{(4 - a)} \dots(iv)$$

For no solution (iii) and (iv) represent parallel lines

$$\text{i.e. } 7 \neq \frac{4 - a}{11} \Rightarrow a \neq -73 \text{ and } \frac{3 - a}{11} = 0 \Rightarrow a = 3$$

(also $a = 4$ is acceptable)

$$\therefore n(S_1) = 2$$

For infinite solution lines shall coincide

$$\text{i.e., } \frac{3 - a}{11} = 0 \text{ and } \frac{1}{11} = \frac{7}{4 - a} \Rightarrow 4 - a = 77$$

$$\Rightarrow a = 3 \quad \text{and} \quad \Rightarrow a = -73$$

$$\therefore n(S_2) = 0$$

4. The distance of line $3y - 2z - 1 = 0 = 3x - z + 4$ from the point $(2, -1, 6)$ is

- (1) $2\sqrt{6}$
- (2) $\sqrt{26}$
- (3) $4\sqrt{2}$
- (4) $2\sqrt{5}$

Answer (1)

Sol. Direction of given line

$$\begin{vmatrix} \hat{i} & \hat{j} & \hat{k} \\ 0 & 3 & -2 \\ 3 & 0 & -1 \end{vmatrix} = \hat{i}(-3) - \hat{j}(6) + \hat{k}(-9) \\ = -3\hat{i} - 6\hat{j} - 9\hat{k}$$

Let $z = 0 \Rightarrow y = \frac{1}{3}$ and $x = -\frac{4}{3}$

\therefore Line in Cartesian form is

$$\frac{x + \frac{4}{3}}{-3} = \frac{y - \frac{1}{3}}{-6} = \frac{z}{-9}$$

Let point of shortest distance be $P(\lambda)$ i.e.

$$P\left(-\lambda - \frac{4}{3}, -2\lambda + \frac{1}{3}, -3\lambda\right) \text{ and } Q(2, -1, 6)$$

For shortest distance $\overline{PQ} \cdot (\hat{i} + 2\hat{j} + 3\hat{k}) = 0$

$$\left(\left(\frac{10}{3} + \lambda\right)\hat{i} + \left(2\lambda - \frac{4}{3}\right)\hat{j} + (6 + 3\lambda)\hat{k}\right) \cdot (\hat{i} + 2\hat{j} + 3\hat{k}) = 0$$

$$\Rightarrow \lambda = -\frac{4}{3}$$

$$\therefore P \equiv (0, 3, 4)$$

$$\therefore |PQ| = 2\sqrt{6}$$

5. Let $S_n = 1 \cdot (n-1) + 2 \cdot (n-2) + 3 \cdot (n-3) + \dots + (n-1) \cdot 1, n \geq 4.$

The sum $\sum_{n=4}^{\infty} \left(\frac{2S_n}{n!} - \frac{1}{(n-2)!}\right)$ is equal to

- (1) $\frac{e-1}{3}$ (2) $\frac{e}{3}$
 (3) $\frac{e}{6}$ (4) $\frac{e-2}{6}$

Answer (1)

Sol. $S_n = 1(n-1) + 2(n-2) + \dots + (n-1)n$

i.e. $T_k = k(n-k)$

$$S_n = \sum_{k=1}^n T_k = \sum_{k=1}^n (kn - k^2) \\ = \frac{n(n(n+1))}{2} - \frac{n(n+1)(2n+1)}{6}$$

$$= \frac{n(n+1)}{2} \left(\frac{3n - (2n+1)}{3}\right) = \frac{n(n^2 - 1)}{6} = S_n$$

$$\sum_{n=4}^{\infty} \left(\frac{2 \cdot S_n}{n!} - \frac{1}{(n-2)!}\right) = \sum_{n=4}^{\infty} \left(\frac{n(n-1)(n+1)}{3n(n-1)(n-2)!} - \frac{1}{(n-2)!}\right)$$

$$= \sum_{n=4}^{\infty} \left(\frac{(n-2)+3}{3(n-2)(n-3)!} - \frac{1}{(n-2)!}\right)$$

$$= \sum_{n=4}^{\infty} \left(\frac{1}{3(n-3)!} + \frac{1}{(n-2)!} - \frac{1}{(n-2)!}\right) = \frac{1}{3}(e-1)$$

6. If $y = y(x)$ is the solution curve of the differential equation $x^2 dy + \left(y - \frac{1}{x}\right) dx = 0; x > 0,$ and $y(1) = 1,$ then $y\left(\frac{1}{2}\right)$ is equal to :

- (1) $3 - e$ (2) $\frac{3}{2} - \frac{1}{\sqrt{e}}$
 (3) $3 + \frac{1}{\sqrt{e}}$ (4) $3 + e$

Answer (1)

Sol. $x^2 dy = \left(\frac{1}{x} - y\right) dx$

$$x^2 \frac{dy}{dx} = \frac{1}{x} - y$$

$$x^2 \frac{dy}{dx} + y = \frac{1}{x}$$

$$\frac{dy}{dx} + \frac{1}{x^2} \cdot y = \frac{1}{x^3} \quad \dots(i)$$

$$IF = e^{\int \frac{1}{x^2} dx} = e^{-\frac{1}{x}}$$

$$y \cdot e^{-\frac{1}{x}} = \int e^{-\frac{1}{x}} \times \frac{1}{x^3} dx$$

Let $\frac{-1}{x} = t, \frac{1}{x^2} dx = dt$

$$y \cdot e^{-\frac{1}{x}} = -\int e^t t dt = -e^t(t-1) + c$$

$$y e^{-\frac{1}{x}} = -e^{-\frac{1}{x}} \left(\frac{-1}{x} - 1\right) + c$$

$$y = \frac{1}{x} + 1 + c e^{\frac{1}{x}}$$

$$y(1) = 1 \Rightarrow 1 = 2 + ce \Rightarrow c = \frac{-1}{e}$$

$$y\left(\frac{1}{2}\right) = 2 + 1 + \left(\frac{-1}{e}\right) \cdot e^2 = 3 - e$$

7. Let θ be the acute angle between the tangents to the ellipse $\frac{x^2}{9} + \frac{y^2}{1} = 1$ and the circle $x^2 + y^2 = 3$ at their point of intersection in the first quadrant. Then $\tan\theta$ is equal to :

- (1) $\frac{2}{\sqrt{3}}$ (2) 2
(3) $\frac{5}{2\sqrt{3}}$ (4) $\frac{4}{\sqrt{3}}$

Answer (1)

Sol. Ellipse : $x^2 + 9y^2 = 9$

Circle : $x^2 + y^2 = 3$

$$x^2 = \frac{9}{4}, y^2 = \frac{3}{4} \Rightarrow x = \frac{\pm 3}{2}, y = \frac{\pm\sqrt{3}}{2}$$

Point of intersection $\left(\frac{\pm 3}{2}, \frac{\pm\sqrt{3}}{2}\right)$

Consider one point, say $\left(\frac{3}{2}, \frac{\sqrt{3}}{2}\right)$

Tangent to ellipse $\frac{3}{2}x + \frac{9\sqrt{3}}{2}y = 9$

$$m_1 = \frac{-1}{3\sqrt{3}}$$

Tangent to circle $\frac{3}{2}x + \frac{\sqrt{3}}{2}y = 3$

$$m_2 = -\sqrt{3}$$

$$\tan\theta = \frac{\frac{-1}{3\sqrt{3}} + \sqrt{3}}{1 + \left(\frac{-1}{3\sqrt{3}}\right) \times (-\sqrt{3})}$$

$$\therefore \frac{8}{4\sqrt{3}} = \frac{2}{\sqrt{3}}$$

8. The area, enclosed by the curves $y = \sin x + \cos x$ and $y = |\cos x - \sin x|$ and the lines $x = 0$, $x = \frac{\pi}{2}$, is :

- (1) $4(\sqrt{2}-1)$ (2) $2\sqrt{2}(\sqrt{2}+1)$
(3) $2\sqrt{2}(\sqrt{2}-1)$ (4) $2(\sqrt{2}+1)$

Answer (3)

Sol. $y = |\cos x - \sin x| = |\sin x - \cos x|$

$$= \begin{cases} \cos x - \sin x & 0 \leq x \leq \frac{\pi}{4} \\ \sin x - \cos x & \frac{\pi}{4} \leq x \leq \frac{\pi}{2} \end{cases}$$

$$A = \int_0^{\pi/4} (\sin x + \cos x) - (\cos x - \sin x) dx$$

$$+ \int_{\pi/4}^{\pi/2} (\sin x + \cos x) - (\sin x - \cos x) dx$$

$$= 2 \int_0^{\pi/4} \sin x dx + 2 \int_{\pi/4}^{\pi/2} \cos x dx = 2(-\cos x)\Big|_0^{\pi/4} + 2 \sin x \Big|_{\pi/4}^{\pi/2}$$

$$= 2\left(1 - \frac{1}{\sqrt{2}}\right) + 2\left(1 - \frac{1}{\sqrt{2}}\right)$$

$$= 4\left(1 - \frac{1}{\sqrt{2}}\right)$$

$$= 2\sqrt{2}(\sqrt{2}-1)$$

9. If n is the number of solutions of the equation

$$2\cos x \left(4\sin\left(\frac{\pi}{4} + x\right)\sin\left(\frac{\pi}{4} - x\right) - 1\right) = 1, x \in [0, \pi]$$

and S is the sum of all these solutions, then the ordered pair (n, S) is :

- (1) $\left(3, \frac{5\pi}{3}\right)$ (2) $\left(3, \frac{13\pi}{9}\right)$
(3) $\left(2, \frac{2\pi}{3}\right)$ (4) $\left(2, \frac{8\pi}{9}\right)$

Answer (2)

Sol. $2\cos x \left(4\sin\left(\frac{\pi}{4} + x\right)\sin\left(\frac{\pi}{4} - x\right) - 1\right) = 1$

$$2\cos x \left(4\left(\sin^2 \frac{\pi}{4} - \sin^2 x\right) - 1\right) = 1$$

$$2\cos x \left(4 \times \frac{1}{2} - 4\sin^2 x - 1\right) = 1$$

$$2\cos x (1 - 2(1 - \cos 2x)) = 1$$

$$4\cos x \cos 2x - 2\cos x = 1$$

$$2[\cos 3x + \cos x] - 2\cos x = 1$$

$$2\cos 3x = 1$$

$$\cos 3x = \frac{1}{2} = \cos \frac{\pi}{3}$$

$$3x = 2n\pi \pm \frac{\pi}{3} = (6n \pm 1) \frac{\pi}{3}$$

$$x = (6n \pm 1) \frac{\pi}{9}$$

$$x = \frac{\pi}{9}, \frac{5\pi}{9}, \frac{7\pi}{9}$$

$$\text{Sum} = \frac{\pi}{9} + \frac{5\pi}{9} + \frac{7\pi}{9} = \frac{13\pi}{9}$$

10. Let a_1, a_2, \dots, a_{21} be an AP such that

$$\sum_{n=1}^{20} \frac{1}{a_n a_{n+1}} = \frac{4}{9}. \text{ If the sum of this AP is } 189, \text{ then}$$

$a_6 a_{16}$ is equal to :

- (1) 36 (2) 57
(3) 72 (4) 48

Answer (3)

Sol. Let first term a and common difference d

$$\frac{1}{a_1 a_2} + \frac{1}{a_2 a_3} + \dots + \frac{1}{a_{20} a_{21}} = \frac{4}{9} \quad \dots(i)$$

$$\text{Also, } a_1 + a_2 + \dots + a_{21} = 189 \quad \dots(ii)$$

by (i)

$$\frac{1}{a_1} - \frac{1}{a_2} + \frac{1}{a_2} - \frac{1}{a_3} + \dots + \frac{1}{a_{20}} - \frac{1}{a_{21}} = \frac{4d}{9}$$

$$\Rightarrow \frac{1}{a} - \frac{1}{a+20d} = \frac{4d}{9}$$

$$\Rightarrow \frac{20d}{a(a+20d)} = \frac{4d}{9} \Rightarrow 45 = a(a+20d) \quad \dots(iii)$$

and

$$21a + 210d = 189 \Rightarrow a + 10d = 9 \quad \dots(iv)$$

by (iii) and (iv)

$$d = \frac{3}{5} \text{ and } a = 3$$

$$\therefore a_6 a_{16} = (3 + 3)(3 + 9) = 72$$

11. Which of the following is equivalent to the Boolean expression $p \wedge \sim q$?

- (1) $\sim(q \rightarrow p)$
(2) $\sim(p \rightarrow \sim q)$
(3) $\sim(p \rightarrow q)$
(4) $\sim p \rightarrow \sim q$

Answer (3)

Sol. $p \wedge \sim q = \sim(\sim p \vee q)$
 $= \sim(p \rightarrow q)$

12. The number of pairs (a, b) of real numbers, such that whenever α is a root of the equation $x^2 + ax + b = 0$, $\alpha^2 - 2$ is also a root of this equation, is :

- (1) 8
(2) 4
(3) 6
(4) 2

Answer (3)

Sol. Let α, β are the roots of a quadratic, then

$$\alpha = \beta^2 - 2 \text{ and } \beta = \alpha^2 - 2$$

$$\Rightarrow (\alpha^2 - 2)^2 - 2 = \alpha \Rightarrow \alpha^4 - 4\alpha^2 - \alpha + 2 = 0$$

$$\Rightarrow (\alpha + 1)(\alpha - 2)(\alpha^2 + \alpha - 1) = 0$$

$$\Rightarrow (\alpha, \beta) = (-1, -1), (-1, 1), (2, 2), (2, -2), (-1, 2)$$

$$\text{and } \left(\frac{\sqrt{5}-1}{2}, -\frac{\sqrt{5}+1}{2} \right)$$

Hence there will be 6 possible values of (a, b) .

13. Two squares are chosen at random on a chessboard (see figure). The probability that they have a side in common is :

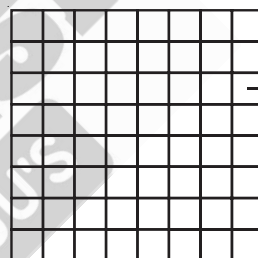

- (1) $\frac{2}{7}$ (2) $\frac{1}{7}$
(3) $\frac{1}{18}$ (4) $\frac{1}{9}$

Answer (3)

Sol. Total ways = ${}^{64}C_2$

$$\text{Favourable ways} = 2(8 \times 7) = 112$$

$$\text{Required probability} = \frac{112}{32 \times 63} = \frac{1}{18}$$

14. The function $f(x)$, that satisfies the condition

$$f(x) = x + \int_0^{\pi/2} \sin x \cdot \cos y f(y) dy, \text{ is :}$$

- (1) $x + (\pi + 2) \sin x$ (2) $x + \frac{2}{3}(\pi - 2) \sin x$
(3) $x + \frac{\pi}{2} \sin x$ (4) $x + (\pi - 2) \sin x$

Answer (4)

Sol. $f(x) = x + \int_0^{\pi/2} \sin x \cdot \cos y f(y) dy$

Let $\int_0^{\pi/2} \cos y f(y) dy = k$

then $f(x) = x + k \sin x$

So, $k = \int_0^{\pi/2} \cos y (y + k \sin y) dy = [y \sin y + \cos y]_0^{\pi/2} - \frac{k}{4} \cos 2y \Big|_0^{\pi/2}$

$\Rightarrow k = \left(\frac{\pi}{2} - 1\right) + \frac{k}{2}$

$\Rightarrow k = \pi - 2$

So $f(x) = x + (\pi - 2) \sin x$

15. The range of the function

$f(x) = \log_{\sqrt{5}} \left(3 + \cos\left(\frac{3\pi}{4} + x\right) + \cos\left(\frac{\pi}{4} + x\right) + \cos\left(\frac{\pi}{4} - x\right) - \cos\left(\frac{3\pi}{4} - x\right) \right)$

is

(1) $[0, 2]$

(2) $[-2, 2]$

(3) $(0, \sqrt{5})$

(4) $\left[\frac{1}{\sqrt{5}}, \sqrt{5}\right]$

Answer (1)

Sol. $f(x) = \log_{\sqrt{5}} \left(3 + 2 \sin\left(\frac{3\pi}{4}\right) \sin(-x) + 2 \cos\left(\frac{\pi}{4}\right) \cdot \cos(x) \right)$

$= \log_{\sqrt{5}} (3 + \sqrt{2}(\cos x - \sin x))$

\therefore Range of $\cos x - \sin x$ is $[-\sqrt{2}, \sqrt{2}]$

Then range of $f(x)$ is $[0, 2]$

16. Consider the parabola with vertex $\left(\frac{1}{2}, \frac{3}{4}\right)$ and the

directrix $y = \frac{1}{2}$. Let P be the point where the

parabola meets the line $x = -\frac{1}{2}$. If the normal to the parabola at P intersects the parabola again at the point Q , then $(PQ)^2$ is equal to

(1) $\frac{15}{2}$

(2) $\frac{125}{16}$

(3) $\frac{75}{8}$

(4) $\frac{25}{2}$

Answer (2)

Sol. The equation of parabola is

$\left(x - \frac{1}{2}\right)^2 = \left(y - \frac{3}{4}\right)$

$\therefore y = x^2 - x + 1$

\therefore Point $P = \left(-\frac{1}{2}, \frac{7}{4}\right)$

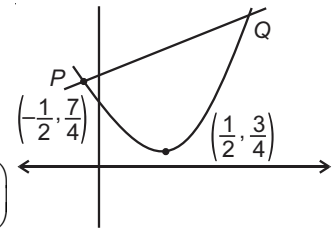

$\therefore \frac{dy}{dx} = 2x - 1$

Slope of normal at $x = -\frac{1}{2}$ is $\frac{1}{2}$.

Equation of normal is : $y - \frac{7}{4} = \frac{1}{2}\left(x + \frac{1}{2}\right)$

$\therefore 2x - 4y + 8 = 0$

$\therefore x - 2y + 4 = 0$

\therefore Coordinate of $Q = (2, 3)$

$\therefore PQ^2 = \left(2 + \frac{1}{2}\right)^2 + \left(3 - \frac{7}{4}\right)^2 = \frac{125}{16}$

17. The function $f(x) = x^3 - 6x^2 + ax + b$ is such that $f(2) = f(4) = 0$. Consider two statements.

(S1) There exists $x_1, x_2 \in (2, 4)$, $x_1 < x_2$, such that $f'(x_1) = -1$ and $f'(x_2) = 0$.

(S2) There exists $x_3, x_4 \in (2, 4)$, $x_3 < x_4$, such that f is decreasing in $(2, x_4)$, increasing in $(x_4, 4)$ and $2f'(x_3) = \sqrt{3}f(x_4)$.

(1) Both (S1) and (S2) are true

(2) Both (S1) and (S2) are false

(3) (S1) is false and (S2) is true

(4) (S1) is true and (S2) is false

Answer (1)

Sol. $\therefore f(2) = f(4) = 0 \Rightarrow a = 8$ and $b = 0$

$f(x) = x^3 - 6x^2 + 8x;$

$f'(x) = 3x^2 - 12x + 8 = 0 \Rightarrow x = 2 + \frac{2}{\sqrt{3}}$

For statement S1, $x_2 = 2 + \frac{2}{\sqrt{3}}$

$\therefore f'(2) = -4$ and $f'(x_2) = 0$ hence there exist x_1 such that $x_1 \in (2, x_2)$ and $f'(x_1) = -1$

\Rightarrow Statement S1 is true.

For statement S2; $x_4 = 2 + \frac{2}{\sqrt{3}}$

So $f'(x_3) = \frac{\sqrt{3}}{2} f(x_4) = -\frac{8}{3}$

$f'(2) < f'(x_3) < f'(x_4)$ so statement S2 is also true.

18. Let $J_{n,m} = \int_0^{\frac{1}{2}} \frac{x^n}{x^m - 1} dx, \forall n > m$ and $n, m \in \mathbb{N}$.

Consider a matrix $A = [a_{ij}]_{3 \times 3}$ where

$$a_{ij} = \begin{cases} J_{6+i, 3} - J_{i+3, 3}, & i \leq j \\ 0, & i > j \end{cases} \text{ Then } |\text{adj } A^{-1}| \text{ is}$$

- (1) $(105)^2 \times 2^{38}$ (2) $(15)^2 \times 2^{42}$
 (3) $(15)^2 \times 2^{34}$ (4) $(105)^2 \times 2^{36}$

Answer (1)

Sol. $J_{6+i, 3} - J_{i+3, 3} = \int_0^{\frac{1}{2}} \frac{x^{6+i}}{x^3 - 1} dx - \int_0^{\frac{1}{2}} \frac{x^{i+3}}{x^3 - 1} dx$
 $= \int_0^{\frac{1}{2}} \frac{x^{i+3}(x^3 - 1)}{(x^3 - 1)} dx$
 $= \left[\frac{x^{i+4}}{i+4} \right]_0^{\frac{1}{2}} = \frac{\left(\frac{1}{2}\right)^{i+4}}{i+4}$

$\therefore \det(A) = a_{11} \cdot a_{22} \cdot a_{33}$

$$= \frac{\left(\frac{1}{2}\right)^5}{5} \cdot \frac{\left(\frac{1}{2}\right)^6}{6} \cdot \frac{\left(\frac{1}{2}\right)^7}{7} = \frac{1}{105 \times 2^{19}}$$

Now, $|\text{adj } A^{-1}| = \frac{1}{(\det A)^2} = (105)^2 \times 2^{38}$

19. Let $f : \mathbb{R} \rightarrow \mathbb{R}$ be a continuous function. Then

$$\lim_{x \rightarrow \frac{\pi}{4}} \frac{\frac{\pi}{4} \int_{\frac{\pi}{4}}^{\sec^2 x} f(x) dx}{x^2 - \frac{\pi^2}{16}}$$
 is equal to

- (1) $f(2)$ (2) $4f(2)$
 (3) $2f(2)$ (4) $2f(\sqrt{2})$

Answer (3)

Sol. $\lim_{x \rightarrow \frac{\pi}{4}} \frac{\frac{\pi}{4} \int_{\frac{\pi}{4}}^{\sec^2 x} f(x) dx}{x^2 - \frac{\pi^2}{16}} = \begin{bmatrix} 0 \\ 0 \end{bmatrix}$

$$= \frac{\pi}{4} \lim_{x \rightarrow \frac{\pi}{4}} \frac{2 \sec^2 x \cdot \tan x \cdot f(\sec^2 x)}{2x}$$

$$= \frac{\pi}{4} \cdot \frac{2 \cdot 1 \cdot f(2)}{\frac{\pi}{4}}$$

$$= 2f(2)$$

20. Let P_1, P_2, \dots, P_{15} be 15 points on a circle. The number of distinct triangles formed by points P_i, P_j, P_k such that $i + j + k \neq 15$, is

- (1) 455 (2) 12
 (3) 419 (4) 443

Answer (4)

Sol. Total number of triangles = ${}^{15}C_3 = 455$

Let $i < j < k$ so $i = 1, 2, 3, 4$ only

When $i = 1, i + j + k = 15$ has 5 solutions

$i = 2, i + j + k = 15$ has 4 solutions

$i = 3, i + j + k = 15$ has 2 solutions

$i = 4, i + j + k = 15$ has 1 solution

Required number of triangles = $455 - 12 = 443$

SECTION - II

Numerical Value Type Questions: This section contains 10 questions. In Section II, attempt any five questions out of 10. The answer to each question is a **NUMERICAL VALUE**. For each question, enter the correct numerical value (in decimal notation, truncated/rounded-off to the second decimal place; e.g. 06.25, 07.00, -00.33, -00.30, 30.27, -27.30) using the mouse and the on-screen virtual numeric keypad in the place designated to enter the answer.

1. Let X be a random variable with distribution.

x	-2	-1	3	4	6
$P(X = x)$	$\frac{1}{5}$	a	$\frac{1}{3}$	$\frac{1}{5}$	b

If the mean X is 2.3 and variance of X is σ^2 , then $100\sigma^2$ is equal to

Answer (781)

Sol. $\frac{1}{5} + \frac{1}{3} + \frac{1}{5} + a + b = 1 \Rightarrow a + b = \frac{4}{15}$

$$\sum P_i X_i = 2.3 \Rightarrow \frac{1}{5}(-2) - a + 1 + \frac{4}{5} + 6b = \frac{23}{10}$$

$$\left. \begin{aligned} -a + 6b &= \frac{9}{10} \\ a + b &= \frac{4}{15} \end{aligned} \right\} \begin{aligned} a &= \frac{1}{10} \\ b &= \frac{1}{6} \end{aligned}$$

$$\begin{aligned} \text{Variance} &= \sum P_i X_i^2 - (\bar{X})^2 \\ &= \left(\frac{1}{5} \cdot 4 + a + 3 + \frac{16}{5} + 36b \right) - \left(\frac{23}{10} \right)^2 \\ &= \frac{781}{100} \end{aligned}$$

$$100\sigma^2 = 781$$

2. All the arrangements, with or without meaning, of the word FARMER are written excluding any word that has two R appearing together. The arrangements are listed serially in the alphabetic order as in the English dictionary. Then the serial number of the word FARMER in this list is _____.

Answer (77)

Sol. First find all possible words and then subtract words from each case that have both R together i.e.,

$$\text{A.....} \Rightarrow \frac{5!}{2!} - 4! = 36$$

$$\text{E.....} \Rightarrow \frac{5!}{2!} - 4! = 36$$

$$\text{FAE.....} \Rightarrow \frac{3!}{2!} - 2 = 1$$

$$\text{FAM.....} \Rightarrow \frac{3!}{2!} - 2 = 1$$

$$\text{FARE.....} \Rightarrow 2! = 2$$

$$\text{FARMER} \Rightarrow 1 = 1$$

77

∴ Rank of farmer is 77

3. Let $[t]$ denote the greatest integer $\leq t$. The number of points where the function

$$f(x) = [x] |x^2 - 1| + \sin\left(\frac{\pi}{[x] + 3}\right) - [x + 1], \quad x \in (-2, 2)$$

is not continuous is _____.

Answer (2)

$$\text{Sol. } f(x) = \begin{cases} -2|x^2 - 1| + 1 & x \in (-2, -1) \\ -|x^2 - 1| + 1 & x \in [-1, 0) \\ \sin\frac{\pi}{3} + 1 & x \in [0, 1) \\ |x^2 - 1| + \frac{1}{\sqrt{2}} - 2 & x \in [1, 2) \end{cases}$$

$$\therefore \text{ at } x = -1 \quad \lim_{x \rightarrow -1^-} f(x) = 1 \text{ and } \lim_{x \rightarrow -1^+} f(x) = 1$$

Hence continuous at $x = -1$

Similarly check at $x = 0$

$$\lim_{x \rightarrow 0^-} f(x) = -1 \text{ and } \lim_{x \rightarrow 0^+} f(x) = 1 + \frac{\sqrt{3}}{2}$$

⇒ discontinuous

and at $x = 1$

$$\lim_{x \rightarrow 1^-} f(x) = 1 + \frac{\sqrt{3}}{2} \text{ and } \lim_{x \rightarrow 1^+} f(x) = \frac{1}{\sqrt{2}} - 2$$

⇒ discontinuous

Hence 2 points of discontinuity.

4. If for the complex number z satisfying $|z - 2 - 2i| \leq 1$, the maximum value of $|3iz + 6|$ is attained at $a + ib$, then $a + b$ is equal to _____.

Answer (5)

Sol.

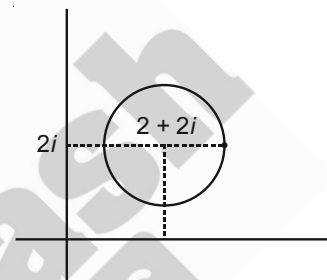

$$|z - 2 - 2i| \leq 1$$

⇒ z lies inside the circle with centre at $2 + 2i$ and radius = 1, as shown in figure.

$$|3iz + 6| = |3i| \left| z + \frac{6}{3i} \right|$$

$$= 3|z - 2i|$$

This is distance of z from $2i$

Hence for maximum value $z = 3 + 2i$ (Refer figure)

Hence $a + b = 5$

5. Let the points of intersections of the lines $x - y + 1 = 0$, $x - 2y + 3 = 0$ and $2x - 5y + 11 = 0$ are the mid points of the sides of a triangle ABC . Then the area of the triangle ABC is _____.

Answer (6)

Sol. Let P.O.I of lines are D, E, F

$$\begin{array}{l|l|l} x - y + 1 = 0 & x - y + 1 = 0 & x - 2y + 3 = 0 \\ x - 2y + 3 = 0 & 2x - 5y + 11 = 0 & 2x - 5y + 11 = 0 \\ \hline x = 1, y = 2 & x = 2, y = 3 & x = 7, y = 5 \end{array}$$

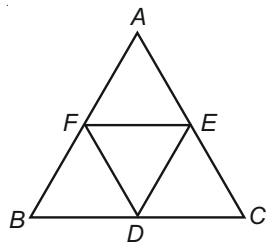

Area of $\triangle ABC = 4$. (Area of $\triangle DEF$)

$$\Delta ABC = 4 \times \frac{1}{2} \begin{vmatrix} 1 & 2 & 1 \\ 2 & 3 & 1 \\ 7 & 5 & 1 \end{vmatrix}$$

$$= |2[1(3 - 5) + 2(7 - 2) + 1(10 - 21)]|$$

$$= |2 \times [-2 + 10 - 11]|$$

$$= 6 \text{ sq. units}$$

6. If the sum of the coefficients in the expansion of $(x + y)^n$ is 4096, then the greatest coefficient in the expansion is _____.

Answer (924)

Sol. Sum of coeff. in $(x + y)^n = 4096$

Put $x = y = 1 \Rightarrow 2^n = 2^{12} \Rightarrow n = 12$

Greatest coeff. in $(x + y)^{12} =$ coeff. of middle term $= {}^{12}C_6$

$$= \frac{12!}{6! \times 6!}$$

$$= \frac{12 \times 11 \times 10 \times 9 \times 8 \times 7}{6 \times 5 \times 4 \times 3 \times 2 \times 1}$$

$$= 924$$

7. Let $\vec{a} = 2\hat{i} - \hat{j} + 2\hat{k}$ and $\vec{b} = \hat{i} + 2\hat{j} - \hat{k}$. Let a vector \vec{v} be in the plane containing \vec{a} and \vec{b} . If \vec{v} is perpendicular to the vector $3\hat{i} + 2\hat{j} - \hat{k}$ and its projection on \vec{a} is 19 units, then $|2\vec{v}|^2$ is equal to _____.

Answer (1494)

Sol. Normal of plane containing \vec{a} and \vec{b} is

$$\vec{n} = \begin{vmatrix} \hat{i} & \hat{j} & \hat{k} \\ 2 & -1 & 2 \\ 1 & 2 & -1 \end{vmatrix} = -3\hat{i} + 4\hat{j} + 5\hat{k}$$

\vec{v} is perpendicular to $(3\hat{i} + 2\hat{j} - \hat{k})$ and also \vec{n}

$$\vec{v} = \lambda \begin{vmatrix} \hat{i} & \hat{j} & \hat{k} \\ 3 & 2 & -1 \\ -3 & 4 & 5 \end{vmatrix} = \lambda[14\hat{i} - 12\hat{j} + 18\hat{k}]$$

Given

$$\frac{\vec{a} \cdot \vec{v}}{|\vec{a}|} = 19 \Rightarrow \frac{\lambda((2)(14) + (-12)(-1) + (18)(2))}{3} = 19$$

$$\lambda = \frac{3}{4}$$

$$\vec{v} = \frac{3}{4}(14\hat{i} - 12\hat{j} + 18\hat{k}) \Rightarrow 2\vec{v} = 3(7\hat{i} - 6\hat{j} + 9\hat{k})$$

$$|2\vec{v}|^2 = 1494$$

8. Let $f(x)$ be a polynomial of degree 3 such that $f(k) = -\frac{2}{k}$ for $k = 2, 3, 4, 5$. Then the value of $52 - 10 f(10)$ is equal to _____.

Answer (26)

Sol. Let $P(k) = kf(k) + 2$

So $kf(k) + 2 = a(x - 2)(x - 3)(x - 4)(x - 5)$

If $k = 0,$

$$2 = a(-2)(-3)(-4)(-5)$$

$$a = \frac{1}{60}$$

$$kf(k) + 2 = \frac{1}{60}(x - 2)(x - 3)(x - 4)(x - 5)$$

Putting $k = 10$

$$10f(10) + 2 = \frac{1}{60} \cdot 8 \cdot 7 \cdot 6 \cdot 5$$

$$= 28$$

$$10f(10) = 26$$

$$52 - 10f(10) = 26$$

9. Let $f(x) = x^6 + 2x^4 + x^3 + 2x + 3, x \in \mathbf{R}$. Then the natural number n for which $\lim_{x \rightarrow 1} \frac{x^n f(1) - f(x)}{x - 1} = 44$ is _____.

Answer (7)

Sol. $\lim_{x \rightarrow 1} \frac{x^n f(1) - f(x)}{x - 1} = 44$

By L.H. Rule

$$\lim_{x \rightarrow 1} (nx^{n-1}f(1) - f'(x)) = 44$$

$$n \cdot f(1) - f'(1) = 44$$

$$n(9) - 19 = 44$$

$$n = 7$$

10. A man starts walking from the point $P(-3, 4)$, touches the x -axis at R , and then turns to reach at the point $Q(0, 2)$. The man is walking at a constant speed. If the man reaches the point Q in the minimum time, then $50(PR)^2 + (RQ)^2$ is equal to _____.

Answer (1250)

Sol.

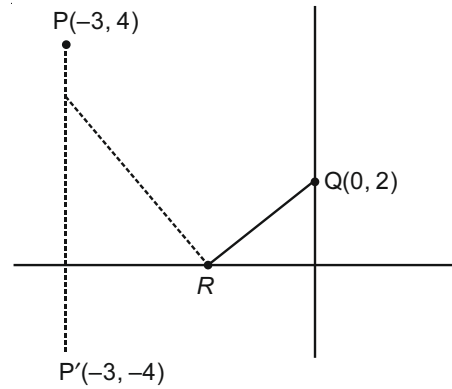

To minimize distance $PR + RQ$

Take mirror image of P in $y = 0$

$$P' = (-3, -4)$$

If we join $P'Q$ we will get required R

$$\text{Equation of } P'Q \Rightarrow y = 2x + 2 \quad \text{So } R = (-1, 0)$$

$$P = (-3, 4) \quad R(-1, 0) \quad Q(0, 2)$$

$$PR^2 + RQ^2 = 20 + 5 = 25$$

