

25/07/2022

Morning



Corporate Office : Aakash Tower, 8, Pusa Road, New Delhi-110005 | Ph.: 011-47623456

Answers & Solutions

Time : 3 hrs.

for

M.M. : 300

JEE (Main)-2022 (Online) Phase-2

(Physics, Chemistry and Mathematics)

IMPORTANT INSTRUCTIONS:

- (1) The test is of **3 hours** duration.
- (2) The Test Booklet consists of 90 questions. The maximum marks are 300.
- (3) There are **three** parts in the question paper consisting of **Physics, Chemistry** and **Mathematics** having 30 questions in each part of equal weightage. Each part (subject) has two sections.
 - (i) **Section-A:** This section contains 20 multiple choice questions which have only one correct answer. Each question carries **4 marks** for correct answer and **-1 mark** for wrong answer.
 - (ii) **Section-B:** This section contains 10 questions. In Section-B, attempt any **five questions out of 10**. The answer to each of the questions is a numerical value. Each question carries **4 marks** for correct answer and **-1 mark** for wrong answer. For Section-B, the answer should be rounded off to the nearest integer.

PHYSICS

SECTION - A

Multiple Choice Questions: This section contains 20 multiple choice questions. Each question has 4 choices (1), (2), (3) and (4), out of which **ONLY ONE** is correct.

Choose the correct answer :

1. If momentum [P], area [A] and time [T] are taken as fundamental quantities, then the dimensional formula for coefficient of viscosity is

- (A) $[PA^{-1}T^0]$ (B) $[PAT^{-1}]$
(C) $[PA^{-1}T]$ (D) $[PA^{-1}T^{-1}]$

Answer (A)

Sol. $[\eta] = [ML^{-1}T^{-1}]$

Now if $[\eta] = [P]^a [A]^b [T]^c$

$$\Rightarrow [ML^{-1}T^{-1}] = [ML^1T^{-1}]^a [L^2]^b [T]^c$$

$$\Rightarrow a = 1, a + 2b = -1, -a + c = -1$$

$$\Rightarrow a = 1, b = -1, c = 0$$

$$\Rightarrow [\eta] = [P] [A]^{-1} [T]^0 \\ = [PA^{-1}T^0]$$

2. Which of the following physical quantities have the same dimensions?

- (A) Electric displacement (\vec{D}) and surface charge density
(B) Displacement current and electric field
(C) Current density and surface charge density
(D) Electric potential and energy

Answer (A)

Sol. Electric displacement (\vec{D}) = $\epsilon_0 \vec{E}$

$$\Rightarrow [\vec{D}] = [\epsilon_0][\vec{E}]$$

$$= [M^{-1}L^{-3}T^4A^2] [ML^1A^{-1}T^{-3}]$$

$$[\vec{D}] = [L^{-2}T^1A^1]$$

$$[\text{Surface charge density}] = \frac{[Q]}{[A]}$$

$$[\sigma] = [ATL^{-2}]$$

$\Rightarrow \vec{D}$ and $[\sigma]$ have same dimensions

3. A person moved from A to B on a circular path as shown in figure. If the distance travelled by him is 60 m, then the magnitude of displacement would be (Given $\cos 135^\circ = -0.7$)

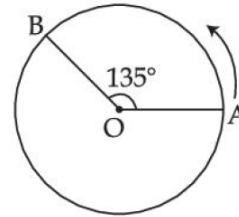

- (A) 42 m (B) 47 m
(C) 19 m (D) 40 m

Answer (B)

Sol. Distance travelled = 60 m

$$\Rightarrow \text{Angle covered} = 135^\circ$$

$$\text{Displacement} = 2R \sin\left(\frac{135^\circ}{2}\right)$$

$$= 2 \left(\frac{60}{135} \times \frac{180}{\pi} \right) \left[\frac{1 - \cos(135^\circ)}{2} \right]^{1/2}$$

$$= 2 \left(\frac{80}{\pi} \right) (0.85)^{1/2}$$

$$\approx 47 \text{ m}$$

4. A body of mass 0.5 kg travels on straight line path with velocity $v = (3x^2 + 4)$ m/s. The net workdone by the force during its displacement from $x = 0$ to $x = 2$ m is

- (A) 64 J (B) 60 J
(C) 120 J (D) 128 J

Answer (B)

Sol. $v = 3x^2 + 4$

$$\text{at } x = 0, v_1 = 4 \text{ m/s}$$

$$x = 2, v_2 = 16 \text{ m/s}$$

\Rightarrow Work done = Δ kinetic energy

$$= \frac{1}{2} \times m (v_2^2 - v_1^2)$$

$$= \frac{1}{2} (256 - 16)$$

$$= 60 \text{ J}$$

5. A solid cylinder and a solid sphere, having same mass M and radius R , roll down the same inclined plane from top without slipping. They start from rest. The ratio of velocity of the solid cylinder to that of the solid sphere, with which they reach the ground, will be

- (A) $\sqrt{\frac{5}{3}}$ (B) $\sqrt{\frac{4}{5}}$
 (C) $\sqrt{\frac{3}{5}}$ (D) $\sqrt{\frac{14}{15}}$

Answer (D)

Sol. $a = \frac{g \sin \theta}{1 + \frac{K^2}{R^2}}$

$$v = \sqrt{\frac{2Sg \sin \theta}{1 + \frac{K^2}{R^2}}}$$

$$\Rightarrow \frac{v_c}{v_{ss}} \sqrt{\frac{1 + \frac{K_{ss}^2}{R^2}}{1 + \frac{K_c^2}{R^2}}} = \sqrt{\frac{1 + \frac{2}{5}}{1 + \frac{1}{2}}}$$

$$\Rightarrow \sqrt{\frac{7}{5}} = \sqrt{\frac{14}{15}}$$

6. Three identical particles A , B and C of mass 100 kg each are placed in a straight line with $AB = BC = 13 \text{ m}$. The gravitational force on a fourth particle P of the same mass is F , when placed at a distance 13 m from the particle B on the perpendicular bisector of the line AC . The value of F will be approximately

- (A) $21G$
 (B) $100G$
 (C) $59G$
 (D) $42G$

Answer (B)

Sol.

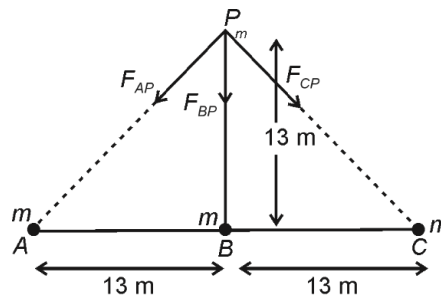

$m = 100 \text{ kg}$

$$F_{AP} = \frac{Gm^2}{(13\sqrt{2})^2}$$

$$F_{BP} = \frac{Gm^2}{13^2}$$

$$F_{CP} = \frac{Gm^2}{(13\sqrt{2})^2}$$

$$F_{\text{net}} = F_{BP} + F_{AP} \cos 45^\circ + F_{CP} \cos 45^\circ$$

$$= \frac{Gm^2}{13^2} \left(1 + \frac{1}{\sqrt{2}} \right)$$

$$= \frac{G100^2}{169} (1 + 0.707)$$

$$\approx 100G$$

7. A certain amount of gas of volume V at 27°C temperature and pressure $2 \times 10^7 \text{ Nm}^{-2}$ expands isothermally until its volume gets doubled. Later it expands adiabatically until its volume gets redoubled. The final pressure of the gas will be (Use, $\gamma = 1.5$)

- (A) $3.536 \times 10^5 \text{ Pa}$ (B) $3.536 \times 10^6 \text{ Pa}$
 (C) $1.25 \times 10^6 \text{ Pa}$ (D) $1.25 \times 10^5 \text{ Pa}$

Answer (B)

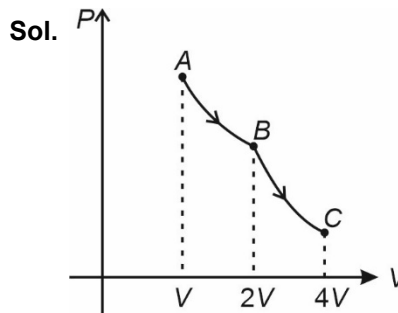

Let AB is isothermal process and BC is adiabatic process then for AB process

$$P_A V_A = P_B V_B$$

$$\Rightarrow P_B = 10^7 \text{ Nm}^{-2}$$

For process BC

$$P_B V_B^{\gamma} = P_C V_C^{\gamma}$$

$$P_C = 3.536 \times 10^6 \text{ Pa}$$

8. Following statements are given:

- (A) The average kinetic energy of a gas molecule decreases when the temperature is reduced.
- (B) The average kinetic energy of a gas molecule increases with increase in pressure at constant temperature.
- (C) The average kinetic energy of a gas molecule decreases with increase in volume.
- (D) Pressure of a gas increases with increase in temperature at constant pressure.
- (E) The volume of gas decreases with increase in temperature.

Choose the correct answer from the options given below:

- (A) (A) and (D) only (B) (A), (B) and (D) only
- (C) (B) and (D) only (D) (A), (B) and (E) only

Answer (Bonus)

Sol. Because $KE \propto T$ so A is correct, B is incorrect, statement C can not be said, statement D is contradicting it self, statement E is incorrect (Isothermal process)

So No answer correct (Bonus)

If the statement of D would have been.

“Pressure of gas increases with increase in temperature at constant volume, “then statement D would have been correct, so in that case answer would have been ‘ A ’

9. In figure (A), mass ' $2m$ ' is fixed on mass ' m ' which is attached to two springs of spring constant k . In figure (B), mass ' m ' is attached to two springs of spring constant ' k ' and ' $2k$ '. If mass ' m ' in (A) and in (B) are displaced by distance ' x ' horizontally and then released, then time period T_1 and T_2 corresponding to (A) and (B) respectively follow the relation.

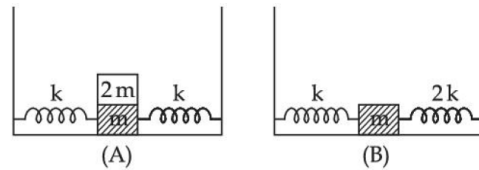

- (A) $\frac{T_1}{T_2} = \frac{3}{\sqrt{2}}$
- (B) $\frac{T_1}{T_2} = \sqrt{\frac{3}{2}}$
- (C) $\frac{T_1}{T_2} = \sqrt{\frac{2}{3}}$
- (D) $\frac{T_1}{T_2} = \frac{\sqrt{2}}{3}$

Answer (A)

Sol. Both the springs are in parallel combination in both the diagrams so

$$T_1 = 2\pi\sqrt{\frac{3m}{2k}}$$

$$\text{and } T_2 = 2\pi\sqrt{\frac{m}{3k}}$$

$$\text{So, } \frac{T_1}{T_2} = \frac{3}{\sqrt{2}}$$

10. A condenser of $2\mu\text{F}$ capacitance is charged steadily from 0 to 5 C. Which of the following graph represents correctly the variation of potential difference (V) across it's plates with respect to the charge (Q) on the condenser?

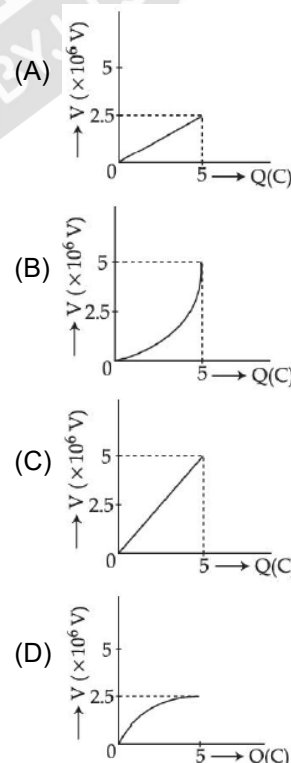

Answer (A)

Sol. $Q = CV$

As capacitance is constant $Q \propto V$

$$\text{and } V_f = \frac{Q_f}{C} = \frac{5}{2 \times 10^{-6}} = 2.5 \times 10^6 \text{ V}$$

So correct graph will be A

11. Two charged particles, having same kinetic energy, are allowed to pass through a uniform magnetic field perpendicular to the direction of motion. If the ratio of radii of their circular path is 6 : 5 and their respective masses ratio is 9 : 4. Then, the ratio of their charges will be :

- (A) 8 : 5 (B) 5 : 4
(C) 5 : 3 (D) 8 : 7

Answer (B)

Sol. We know that $R = \frac{mv}{Bq} = \sqrt{\frac{2mK}{Bq}}$

$$\Rightarrow \text{Ratio of radii} = \frac{R_1}{R_2} = \sqrt{\frac{m_1 q_2}{m_2 q_1}}$$

$$\Rightarrow \frac{6}{5} = \sqrt{\frac{9 q_2}{4 q_1}}$$

$$\Rightarrow \frac{q_1}{q_2} = \frac{3}{2} \times \frac{5}{6} = \frac{5}{4}$$

12. To increase the resonant frequency in series LCR circuit,

- (A) Source frequency should be increased.
(B) Another resistance should be added in series with the first resistance.
(C) Another capacitor should be added in series with the first capacitor.
(D) The source frequency should be decreased.

Answer (C)

Sol. Resonant frequency $= \frac{1}{\sqrt{LC}} = \omega_0$

\Rightarrow If we decrease C, ω_0 would increase

\Rightarrow Another capacitor should be added in series.

13. A small square loop of wire of side l is placed inside a large square loop of wire L ($L \gg l$). Both loops are coplanar and their centres coincide at point O as shown in figure. The mutual inductance of the system is :

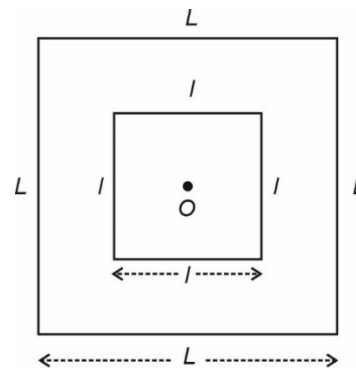

- (A) $\frac{2\sqrt{2} \mu_0 L^2}{\pi l}$ (B) $\frac{\mu_0 l^2}{2\sqrt{2} \pi L}$
(C) $\frac{2\sqrt{2} \mu_0 l^2}{\pi L}$ (D) $\frac{\mu_0 L^2}{2\sqrt{2} \pi l}$

Answer (C)

Sol. We know $\phi = Mi$

Let i current be flowing in the larger loop

$$\Rightarrow \phi = \left[4 \times \frac{\mu_0 i}{4\pi(L/2)} [\sin 45^\circ + \sin 45^\circ] \right] \times \text{Area}$$

$$= \frac{2\sqrt{2} \mu_0 i}{\pi L} \times l^2$$

$$\Rightarrow M = \frac{\phi}{i} = \frac{2\sqrt{2} \mu_0 l^2}{\pi L}$$

14. The rms value of conduction current in a parallel plate capacitor is 6.9 μ A. The capacity of this capacitor, if it is connected to 230 V ac supply with an angular frequency of 600 rad/s, will be :

- (A) 5 pF (B) 50 pF
(C) 100 pF (D) 200 pF

Answer (B)

Sol. $Z_C = \frac{V}{I}$

$$\Rightarrow \frac{1}{\omega C} = \frac{230}{6.9} M \Omega$$

$$\Rightarrow C = \frac{6.9}{230 \omega} \mu F$$

$$= \frac{6.9}{230 \times 600} \mu F$$

$$C = 50 \text{ pF}$$

15. Which of the following statement is correct?
- (A) In primary rainbow, observer sees red colour on the top and violet on the bottom
- (B) In primary rainbow, observer sees violet colour on the top and red on the bottom
- (C) In primary rainbow, light wave suffers total internal reflection twice before coming out of water drops
- (D) Primary rainbow is less bright than secondary rainbow

Answer (A)

Sol. In primary rainbow, observer sees red colour on the top and violet on the bottom.

16. Time taken by light to travel in two different materials *A* and *B* of refractive indices μ_A and μ_B of same thickness is t_1 and t_2 respectively. If $t_2 - t_1 = 5 \times 10^{-10}$ s and the ratio of μ_A to μ_B is 1 : 2. Then, the thickness of material, in meter is: (Given v_A and v_B are velocities of light in *A* and *B* materials respectively.)
- (A) $5 \times 10^{-10} v_A$ m (B) 5×10^{-10} m
- (C) 1.5×10^{-10} m (D) $5 \times 10^{-10} v_B$ m

Answer (A)

Sol. $t_2 - t_1 = 5 \times 10^{-10}$

$$\Rightarrow \frac{d}{v_B} - \frac{d}{v_A} = 5 \times 10^{-10}$$

$$\text{and, } \frac{v_B}{v_A} = \frac{\mu_A}{\mu_B} = \frac{1}{2}$$

$$\Rightarrow d \left(1 - \frac{v_B}{v_A} \right) = 5 \times 10^{-10} \times v_B$$

$$\Rightarrow d \left(1 - \frac{1}{2} \right) = 5 \times 10^{-10} \times v_B$$

$$\Rightarrow d = 10 \times 10^{-10} \times v_B \text{ m}$$

$$\Rightarrow d = 5 \times 10^{-10} \times v_A \text{ m}$$

17. A metal exposed to light of wavelength 800 nm and emits photoelectrons with a certain kinetic energy. The maximum kinetic energy of photo-electron doubles when light of wavelength 500 nm is used. The workfunction of the metal is:

(Take $hc = 1230$ eV-nm)

- (A) 1.537 eV (B) 2.46 eV
- (C) 0.615 eV (D) 1.23 eV

Answer (C)

Sol. $\therefore K_m = \frac{hc}{\lambda} - \phi$

$$\Rightarrow K = \frac{1230}{800} - \phi$$

$$\text{and, } 2K = \frac{1230}{500} - \phi$$

$$\Rightarrow 2 \times \frac{1230}{800} - 2\phi = \frac{1230}{500} - \phi$$

$$\Rightarrow \phi = 0.615 \text{ eV}$$

18. The momentum of an electron revolving in n^{th} orbit is given by: (Symbols have their usual meanings)

(A) $\frac{nh}{2\pi r}$

(B) $\frac{nh}{2r}$

(C) $\frac{nh}{2\pi}$

(D) $\frac{2\pi r}{nh}$

Answer (A)

Sol. $\therefore mvr = \frac{nh}{2\pi}$

$$\Rightarrow mv = \frac{nh}{2\pi r}$$

19. The magnetic moment of an electron (*e*) revolving in an orbit around nucleus with an orbital angular momentum is given by:

(A) $\vec{\mu}_L = \frac{e\vec{L}}{2m}$

(B) $\vec{\mu}_L = -\frac{e\vec{L}}{2m}$

(C) $\vec{\mu}_L = -\frac{e\vec{L}}{m}$

(D) $\vec{\mu}_L = \frac{2e\vec{L}}{m}$

Answer (B)

Sol. $\therefore \vec{\mu} = \frac{q\vec{L}}{2m}$

$$\Rightarrow \vec{\mu} = \frac{-e\vec{L}}{2m}$$

20. In the circuit, the logical value of $A = 1$ or $B = 1$ when potential at A or B is 5 V and the logical value of $A = 0$ or $B = 0$ when potential at A or B is 0 V .

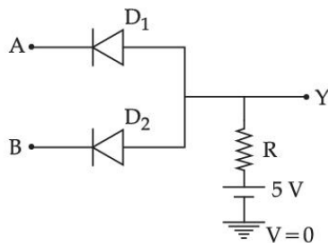

The truth table of the given circuit will be:

(A)

A	B	Y
0	0	0
1	0	0
0	1	0
1	1	1

(B)

A	B	Y
0	0	0
1	0	1
0	1	1
1	1	1

(C)

A	B	Y
0	0	0
1	0	0
0	1	0
1	1	0

(D)

A	B	Y
0	0	1
1	0	1
0	1	1
1	1	0

Answer (A)

Sol. Given circuit is equivalent to an AND gate.

∴

A	B	Y
0	0	0
0	1	0
1	0	0
1	1	1

SECTION - B

Numerical Value Type Questions: This section contains 10 questions. In Section B, attempt any five questions out of 10. The answer to each question is a **NUMERICAL VALUE**. For each question, enter the correct numerical value (in decimal notation, truncated/rounded-off to the second decimal place; e.g. 06.25, 07.00, -00.33, -00.30, 30.27, -27.30) using the mouse and the on-screen virtual numeric keypad in the place designated to enter the answer.

1. A car is moving with speed of 150 km/h and after applying the break it will move 27 m before it stops. If the same car is moving with a speed of one third the reported speed then it will stop after travelling ___ m distance.

Answer (3)

Sol. $F_R d = \frac{1}{2}mv^2$

$$\frac{d_2}{d_1} = \left(\frac{v_2}{v_1}\right)^2 = \left(\frac{1}{3}\right)^2$$

$$d_2 = d_1 \times \frac{1}{9} = 3\text{m}$$

2. For forces are acting at a point P in equilibrium as shown in figure. The ratio of force F_1 to F_2 is $1 : x$ where $x = \underline{\hspace{1cm}}$.

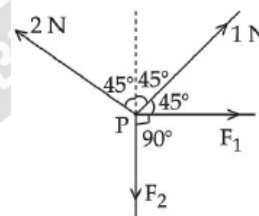

Answer (3)

Sol. $F_1 = +2 \times \frac{1}{\sqrt{2}} - \frac{1}{\sqrt{2}} = \frac{1}{\sqrt{2}}$

$$F_2 = 2 \times \frac{1}{\sqrt{2}} + \frac{1}{\sqrt{2}} = \frac{3}{\sqrt{2}}$$

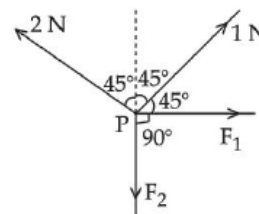

$$\frac{F_1}{F_2} = \frac{1}{3} = \frac{1}{x} \Rightarrow x = 3$$

3. A wire of length L and radius r is clamped rigidly at one end. When the other end of the wire is pulled by a force F , its length increases by 5 cm. Another wire of the same material of length $4L$ and radius $4r$ is pulled by a force $4F$ under same conditions. The increase in length of this wire is ___ cm.

Answer (5)

Sol. $\frac{F/A}{\Delta L/L} = Y$

$$\Rightarrow \Delta L = \frac{FL}{AY}$$

$$\frac{\Delta L_2}{\Delta L_1} = \left(\frac{F_2}{F_1}\right) \times \left(\frac{L_2}{L_1}\right) \times \left(\frac{A_1}{A_2}\right)$$

$$= 4 \times 4 \times \frac{1}{16} = 1$$

$$\Delta L_2 = \Delta L_1 = 5 \text{ cm.}$$

4. A unit scale is to be prepared whose length does not change with temperature and remains 20 cm, using a bimetallic strip made of brass and iron each of different length. The length of both components would change in such a way that difference between their lengths remains constant. If length of brass is 40 cm and length of iron will be ___ cm.

$$(\alpha_{\text{iron}} = 1.2 \times 10^{-5} \text{ K}^{-1} \text{ and } \alpha_{\text{brass}} = 1.8 \times 10^{-5} \text{ K}^{-1}).$$

Answer (60)

Sol. $\Delta L_1 = \alpha_1 L_1 \Delta T$

$$\Delta L_2 = \alpha_2 L_2 \Delta T$$

$$\alpha_1 L_1 = \alpha_2 L_2$$

$$1.2 \times 10^{-5} \times L_1 = 1.8 \times 10^{-5} L_2$$

$$L_1 = \frac{1.8}{1.2} \times 40 = 60 \text{ cm}$$

5. An observer is riding on a bicycle and moving towards a hill at 18 kmh^{-1} . He hears a sound from a source at some distance behind him directly as well as after its reflection from the hill. If the original frequency of the sound as emitted by source is 640 Hz and velocity of the sound in air is 320 m/s, the beat frequency between the two sounds heard by observer will be ___ Hz.

Answer (20)

Sol.

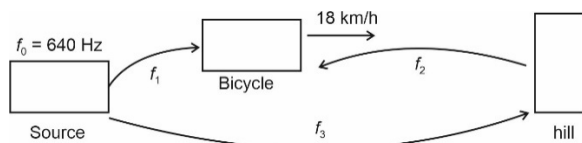

$$f_1 = f_0 \left(\frac{320 - 5}{320}\right) = 640 \left(\frac{315}{320}\right)$$

$$= 630 \text{ Hz}$$

$$f_3 = f_0 \text{ [No relative motion]}$$

$$f_2 = f_0 \left[\frac{320 + 5}{320}\right] = 640 \left(\frac{325}{320}\right)$$

$$= 650$$

$$\text{Beat frequency} = f_2 - f_1$$

$$= 650 - 630 = 20 \text{ Hz}$$

6. The volume charge density of a sphere of radius 6 m is $2 \mu\text{C cm}^{-3}$. The number of lines of force per unit surface area coming out from the surface of the sphere is _____ $\times 10^{10} \text{ NC}^{-1}$.

$$[\text{Given : Permittivity of vacuum } \epsilon_0 = 8.85 \times 10^{-12} \text{ C}^2 \text{ N}^{-1} \text{ m}^{-2}).$$

Answer (45)

Sol. $\rho = 2 \mu\text{C/cm}^3$

$$R = 6 \text{ m}$$

Number of lines of force per unit area = Electric field at surface.

$$= \frac{KQ}{R^2}$$

$$= \frac{1}{4\pi\epsilon_0} \frac{\rho \frac{4}{3}\pi R^3}{R^2}$$

$$= \frac{\rho R}{3\epsilon_0}$$

$$= \frac{2 \times 10^{-6} \times 10^6 \times 6}{3 \times 8.85 \times 10^{-12}}$$

$$= 0.45197 \times 10^{12}$$

$$= 45.19 \times 10^{10} \text{ N/C}$$

$$\approx 45 \times 10^{10}$$

7. In the given figure, the value of V_0 will be _____ V.

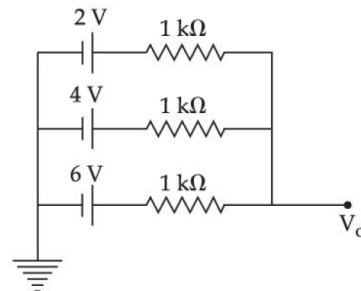

Answer (4)

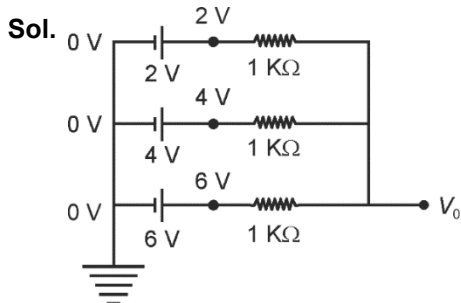

Using Kirchoff's junction rule.

$$\frac{2 - V_0}{1} + \frac{4 - V_0}{1} + \frac{6 - V_0}{1} = 0$$

$$12 - 3V_0 = 0$$

$$V_0 = 4 \text{ V}$$

8. Eight copper wire of length l and diameter d are joined in parallel to form a single composite conductor of resistance R . If a single copper wire of length $2l$ have the same resistance (R) then its diameter will be _____ d .

Answer (4)

Sol.

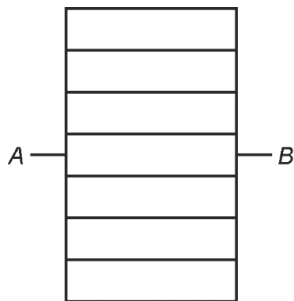

$$RAB = R$$

$$R = \frac{1}{8} (\text{Resistance of one wire})$$

$$= \frac{1}{8} \rho \frac{l}{\pi \frac{d^2}{4}} = \frac{\rho l}{2\pi d^2}$$

Resistance of copper wire of length $2l$ and diameter $x = R$.

$$\rho \frac{2l}{\pi \frac{x^2}{4}} = R$$

$$\frac{8\rho l}{\pi x^2} = \frac{\rho l}{2\pi d^2}$$

$$16d^2 = x^2$$

$$x = 4d$$

9. The energy band gap of semiconducting material to produce violet (wavelength = 4000 \AA) LED is _____ eV. (Round off to the nearest integer).

Answer (3)

Sol. Energy corresponding to wavelength 4000 \AA

$$E = \frac{hc}{\lambda}$$

$$= \frac{6.6 \times 10^{-34} \times 3 \times 10^8}{4000 \times 10^{-10} \times 1.6 \times 10^{-19}} \text{ eV}$$

$$= \frac{12400}{4000}$$

$$= 3.1 \text{ eV}$$

$$\approx 3 \text{ eV}$$

10. The required height of a TV tower which can cover the population of 6.03 lakh is h . If the average population density is 100 per square km and the radius of earth is 6400 km, then the value of h will be _____ m.

Answer (150)

Sol.

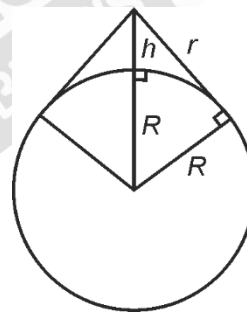

$$r = \sqrt{(h + R)^2 - R^2} \approx \sqrt{2hR}$$

$$A = \frac{6.03 \times 10^5}{100}$$

$$\pi r^2 = 6.03 \times 10^3$$

$$\pi 2Rh = 6.03 \times 10^3$$

$$h = \frac{6.03 \times 10^3}{2 \times \pi \times R} = 0.015 \times 10 \times 10^3 \text{ m}$$

$$= 150 \text{ m}$$

CHEMISTRY

SECTION - A

Multiple Choice Questions: This section contains 20 multiple choice questions. Each question has 4 choices (1), (2), (3) and (4), out of which **ONLY ONE** is correct.

Choose the correct answer :

1. SO_2Cl_2 on reaction with excess of water results into acidic mixture

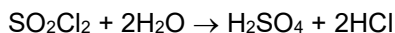

16 moles of NaOH is required for the complete neutralisation of the resultant acidic mixture. The number of moles of SO_2Cl_2 used is

- (A) 16
(B) 8
(C) 4
(D) 2

Answer (C)

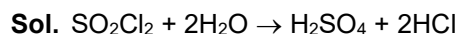

Moles of NaOH required for complete neutralisation of resultant acidic mixture = 16 moles

And 1 mole of SO_2Cl_2 produced 4 moles of H^+ .

$$\therefore \text{Moles of } \text{SO}_2\text{Cl}_2 \text{ used will be} = \frac{16}{4} = 4 \text{ moles}$$

2. Which of the following sets of quantum numbers is not allowed?

- (A) $n = 3, l = 2, m_l = 0, s = +\frac{1}{2}$
(B) $n = 3, l = 2, m_l = -2, s = +\frac{1}{2}$
(C) $n = 3, l = 3, m_l = -3, s = -\frac{1}{2}$
(D) $n = 3, l = 0, m_l = 0, s = -\frac{1}{2}$

Answer (C)

Sol. If $n = 3$, then possible values of $l = 0, 1, 2$

But in option (C), the value of l is given '3', this is not possible.

3. The depression in freezing point observed for a formic acid solution of concentration 0.5 mL L^{-1} is 0.0405°C . Density of formic acid is 1.05 g mL^{-1} . The Van't Hoff factor of the formic acid solution is nearly (Given for water $k_f = 1.86 \text{ k kg mol}^{-1}$)

- (A) 0.8
(B) 1.1
(C) 1.9
(D) 2.4

Answer (C)

Sol. ΔT_f of formic acid = 0.0405°C

Concentration = 0.5 mL/L

and density = 1.05 g/mL

$$\therefore \text{Mass of formic acid in solution} = 1.05 \times 0.5 \text{ g} = 0.525 \text{ g}$$

\therefore According to Van't Hoff equation,

$$\Delta T_f = i k_f m$$

$$0.0405 = i \times 1.86 \times \frac{0.525}{46 \times 1}$$

(Assuming mass of 1 L water = kg)

$$i = \frac{0.0405 \times 46}{1.86 \times 0.525} = 1.89 \approx 1.9$$

4. 20 mL of 0.1 M NH_4OH is mixed with 40 mL of 0.05 M HCl. The pH of the mixture is nearest to (Given : $K_b(\text{NH}_4\text{OH}) = 1 \times 10^{-5}$, $\log 2 = 0.30$, $\log 3 = 0.48$, $\log 5 = 0.69$, $\log 7 = 0.84$, $\log 11 = 1.04$)

- (A) 3.2
(B) 4.2
(C) 5.2
(D) 6.2

Answer (C)

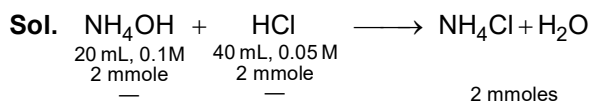

\therefore In final solution 2 millimoles of NH_4Cl is present.

$$\therefore [\text{NH}_4\text{Cl}] = \frac{1}{30} \text{ molar}$$

$$\begin{aligned} \text{pH} &= \frac{1}{2} [\text{p}K_w - \text{p}K_b - \log C] \\ &= \frac{1}{2} [14 - 5 - (-1.48)] \\ &= 5.24 \end{aligned}$$

5. Match **List-I** with **List-II**.

List-I	List-II
(A) $\text{N}_2(\text{g}) + 3\text{H}_2(\text{g}) \rightarrow 2\text{NH}_3(\text{g})$	(I) Cu
(B) $\text{CO}(\text{g}) + 3\text{H}_2(\text{g}) \rightarrow \text{CH}_4(\text{g}) + \text{H}_2\text{O}(\text{g})$	(II) Cu/ZnO - Cr_2O_3
(C) $\text{CO}(\text{g}) + \text{H}_2(\text{g}) \rightarrow \text{HCHO}(\text{g})$	(III) $\text{Fe}_x\text{O}_y + \text{K}_2\text{O} + \text{Al}_2\text{O}_3$
(D) $\text{CO}(\text{g}) + 2\text{H}_2(\text{g}) \rightarrow \text{CH}_3\text{OH}(\text{g})$	(IV) Ni

Choose the **correct** answer from the options given below :

- (A) (A) - (II), (B) - (IV), (C) - (I), (D) - (III)
 (B) (A) - (II), (B) - (I), (C) - (IV), (D) - (III)
 (C) (A) - (III), (B) - (IV), (C) - (I), (D) - (II)
 (D) (A) - (III), (B) - (I), (C) - (IV), (D) - (II)

Answer (C)

Sol. Here, we have to match the reactions with their correct catalyst :

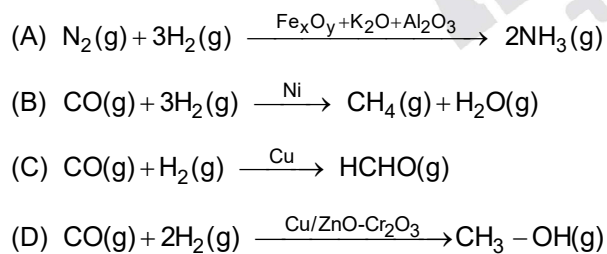

∴ Option (C) is correct option.

6. The IUPAC nomenclature of an element with electronic configuration $[\text{Rn}] 5f^{14}6d^{17}s^2$ is

- (A) Unnilbium (B) Unnilunium
 (C) Unnilquadium (D) Unniltrium

Answer (D)

Sol. The element with electronic configuration $[\text{Rn}] 5f^{14}6d^{17}s^2$ has atomic number $\rightarrow 103$

∴ Its IUPAC name is : Unniltrium

7. The compound(s) that is(are) removed as slag during the extraction of copper is

- (A) CaO
 (B) FeO
 (C) Al_2O_3
 (D) ZnO
 (E) NiO

Choose the correct answer from the options given below :

- (A) (C), (D) only (B) (A), (B), (E) only
 (C) (A), (B) only (D) (B) only

Answer (D)

Sol. The compound(s) that are removed as a slag during the extraction of copper is :

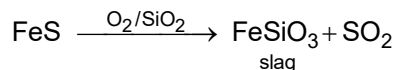

∴ Only iron oxide (FeO) formed slag during extraction of copper.

8. The reaction of H_2O_2 with potassium permanganate in acidic medium leads to the formation of mainly

- (A) Mn^{2+} (B) Mn^{4+}
 (C) Mn^{3+} (D) Mn^{6+}

Answer (A)

Sol. The reaction of KMnO_4 with H_2O_2 in acidic medium is as

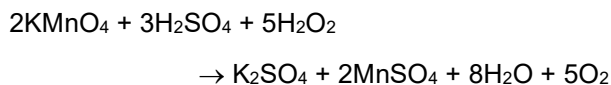

∴ Mn^{2+} will be formed as the product.

9. Choose the **correct** order of density of the alkali metals.

- (A) $\text{Li} < \text{K} < \text{Na} < \text{Rb} < \text{Cs}$
 (B) $\text{Li} < \text{Na} < \text{K} < \text{Rb} < \text{Cs}$
 (C) $\text{Cs} < \text{Rb} < \text{K} < \text{Na} < \text{Li}$
 (D) $\text{Li} < \text{Na} < \text{K} < \text{Cs} < \text{Rb}$

Answer (A)

Sol. The increasing order of density of alkali metals as

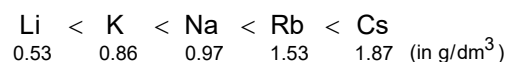

'K' metal has less density as compare to 'Na' metal.

10. The geometry around boron in the product 'B' formed from the following reaction is

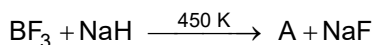

- (A) Trigonal planar
(B) Tetrahedral
(C) Pyramidal
(D) Square planar

Answer (B)

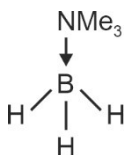
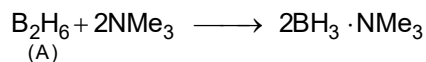
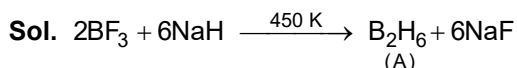

∴ Geometry of boron will be tetrahedral.

11. The interhalogen compound formed from the reaction of bromine with excess of fluorine is a :

- (A) hypohalite
(B) halate
(C) perhalate
(D) halite

Answer (B)

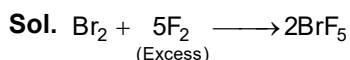

If BrF_5 undergoes hydrolysis it will produce halide.

12. The photochemical smog does not generally contain :

- (A) NO
(B) NO_2
(C) SO_2
(D) HCHO

Answer (C)

Sol. Photochemical smog contain:

Ozone, nitric oxide, organic compounds, nitrogen dioxide, formaldehyde.

∴ SO_2 is not the part of photochemical smog.

13. A compound 'A' on reaction with 'X' and 'Y' produces the same major product but different by product 'a' and 'b'. Oxidation of 'a' gives a substance produced by ants.

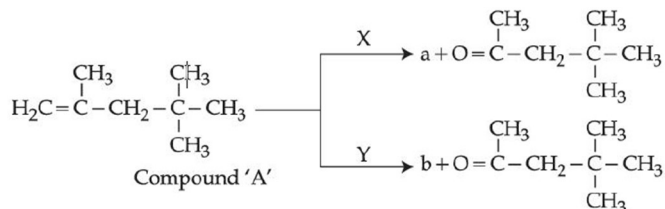

'X' and 'Y' respectively are

- (A) KMnO_4/H^+ and dil. KMnO_4 , 273 K
(B) KMnO_4 (dilute), 273 K and KMnO_4/H^+
(C) KMnO_4/H^+ and O_3 , $\text{H}_2\text{O}/\text{Zn}$
(D) O_3 , $\text{H}_2\text{O}/\text{Zn}$ and KMnO_4/H^+

Answer (D)

Sol.

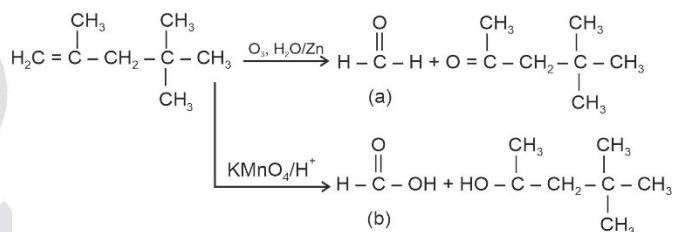

* Ants produce formic acid in their venom gland.

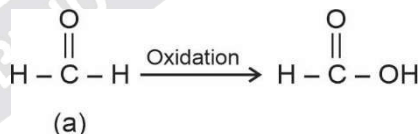

14. Most stable product of the following reaction is :

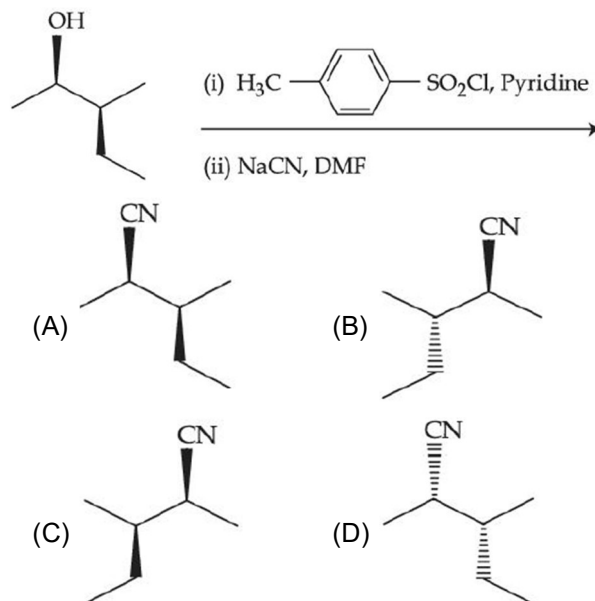

Answer (B)

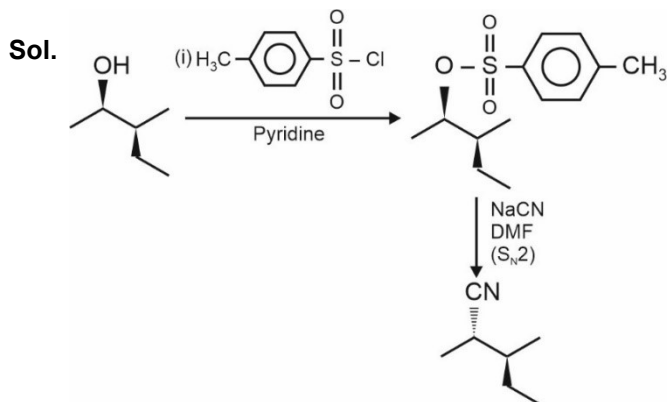

∴ Option (B) is correct option.

15. Which one of the following reactions does not represent correct combination of substrate and product under the given conditions?

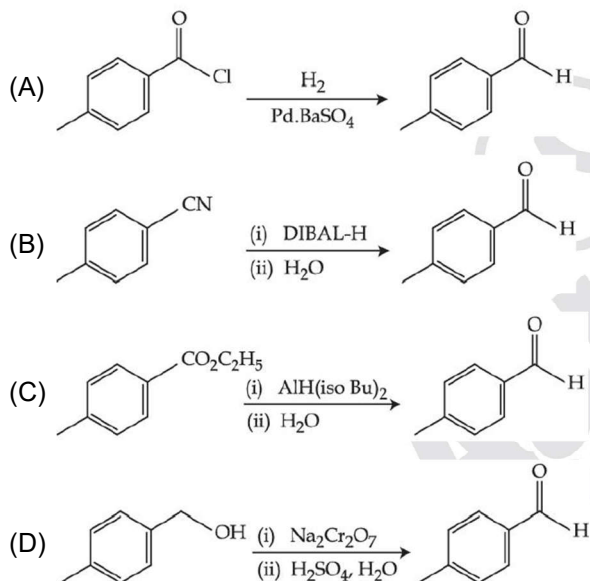

Answer (D)

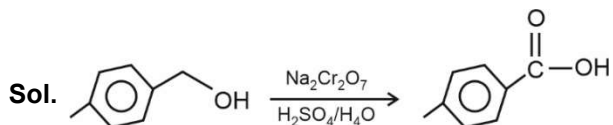

$\text{Na}_2\text{Cr}_2\text{O}_7$, $\text{H}_2\text{SO}_4/\text{H}_2\text{O}$ is the strongest oxidising agent and it will oxidise 1° alcohol into acids.

16. An organic compound 'A' on reaction with NH_3 followed by heating gives compound B. Which on further strong heating gives compound C ($\text{C}_8\text{H}_5\text{NO}_2$). Compound C on sequential reaction with ethanolic KOH, alkyl chloride and hydrolysis with alkali gives a primary amine. The compound A is :

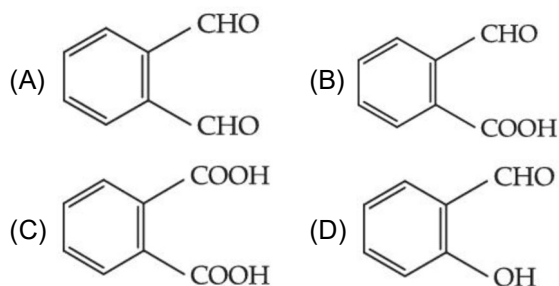

Answer (C)

Sol.

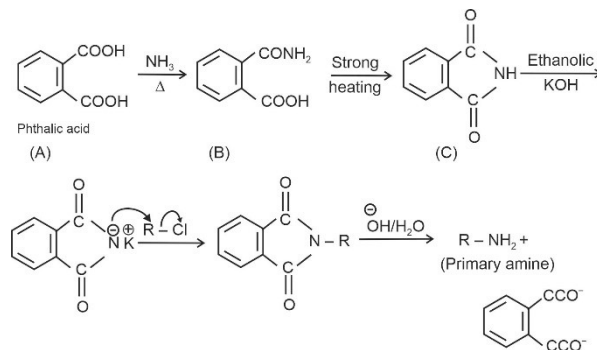

All the given reactions can be explained if organic compound (A) is phthalic acid.

17. Melamine polymer is formed by the condensation of :

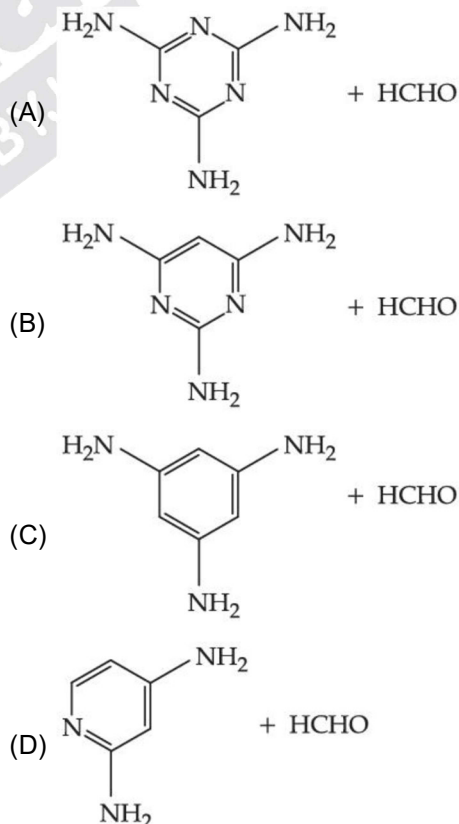

Answer (A)

Sol. Melamine polymer is formed by the condensation polymerisation of melamine and formaldehyde.

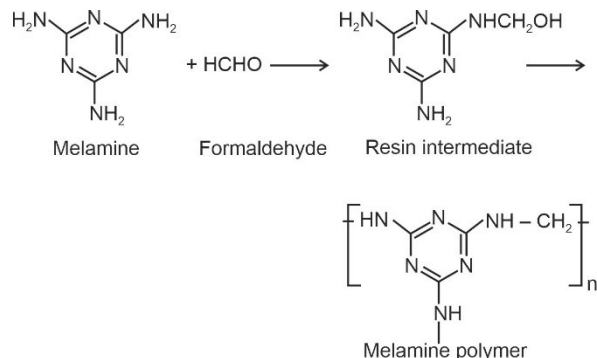

18. During the denaturation of proteins, which of these structures will remain intact?

- (A) Primary (B) Secondary
(C) Tertiary (D) Quaternary

Answer (A)

Sol. During the denaturation of proteins hydrogen bonds are disturbed. As a result, the secondary and tertiary structures are destroyed but the primary structures remain intact.

19. Drugs used to bind to receptors, inhibiting its natural function and blocking a message are called:

- (A) Agonists (B) Antagonists
(C) Allosterists (D) Anti histaminists

Answer (B)

Sol. Drugs that bind to the receptor site and inhibit its natural function are called Antagonists.

20. Given below are two statements:

Statement I: On heating with KHSO_4 , glycerol is dehydrated and acrolein is formed.

Statement II: Acrolein has fruity odour and can be used to test glycerol's presence.

Choose the **correct** option.

- (A) Both Statement I and Statement II are correct.
(B) Both Statement I and Statement II are incorrect.
(C) Statement I is correct but Statement II is incorrect.
(D) Statement I is incorrect but Statement II is correct.

Answer (C)

Sol. Glycerol, on heating with KHSO_4 , undergoes dehydration to give unsaturated aldehyde called acrolein. So, statement I is correct.

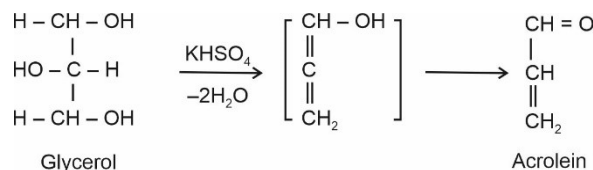

Acrolein has piercing unpleasant smell. So, statement-II is incorrect.

SECTION - B

Numerical Value Type Questions: This section contains 10 questions. In Section B, attempt any five questions out of 10. The answer to each question is a **NUMERICAL VALUE**. For each question, enter the correct numerical value (in decimal notation, truncated/rounded-off to the second decimal place; e.g. 06.25, 07.00, -00.33, -00.30, 30.27, -27.30) using the mouse and the on-screen virtual numeric keypad in the place designated to enter the answer.

1. Among the following species



the number of species showing diamagnetism is _____.

Answer (2)

Sol. According to molecules orbital theory. The electronic configurations of the given species are

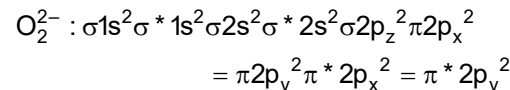
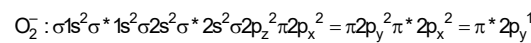
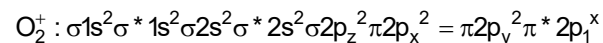
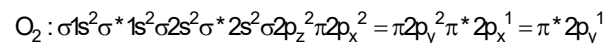
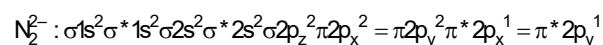
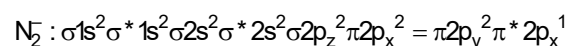
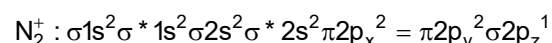
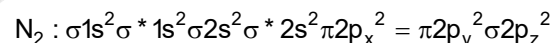

Diamagnetic species are N_2 and O_2^{2-}

\therefore Number of species showing diamagnetism = 2

2. The enthalpy of combustion of propane, graphite and dihydrogen at 298 K are $-2220.0 \text{ kJ mol}^{-1}$, $-393.5 \text{ kJ mol}^{-1}$ and $-285.8 \text{ kJ mol}^{-1}$ respectively. The magnitude of enthalpy of formation of propane (C_3H_8) is _____ kJ mol^{-1} . (Nearest integer)

Answer (104)

Sol. Enthalpy of combustion of propane, graphite and H_2 at 298K are

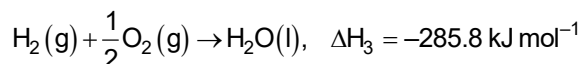
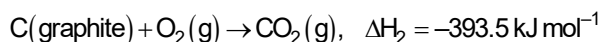
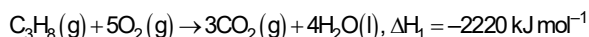

The desired reaction is

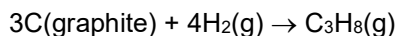

$$\begin{aligned} \Delta H_f &= 3\Delta H_2 + 4\Delta H_3 - \Delta H_1 \\ &= 3(-393.5) + 4(-285.8) - (-2220) \\ &= -103.7 \text{ kJ mol}^{-1} \end{aligned}$$

$$|\Delta H_f| = 104 \text{ kJ mol}^{-1}$$

3. The pressure of a moist gas at 27°C is 4 atm. The volume of the container is doubled at the same temperature. The new pressure of the moist gas is _____ $\times 10^{-1}$ atm. (Nearest integer)
(Given: The vapour pressure of water at 27°C is 0.4 atm.)

Answer (22)

Sol. From ideal gas equation,

$$P \propto \frac{1}{V}$$

$$P_1V_1 = P_2V_2$$

$$\text{Pressure of the gas} = 4 - 0.4 = 3.6 \text{ atm}$$

$$3.6 V_1 = P_2 (2V_1)$$

$$P_2 = 1.8 \text{ atm}$$

Hence, new pressure of moist gas is $1.8 + 0.4 = 2.2 \text{ atm} = 22 \times 10^{-1} \text{ atm}$

4. The cell potential for $\text{Zn}|\text{Zn}^{2+}(\text{aq})||\text{Sn}^{+x}|\text{Sn}$ is 0.801 V at 298 K. The reaction quotient for the above reaction is 10^{-2} . The number of electrons involved in the given electrochemical cell reaction is _____.

$$\left(\text{Given: } E_{\text{Zn}^{2+}|\text{Zn}}^\circ = -0.763 \text{ V}, E_{\text{Sn}^{+x}|\text{Sn}}^\circ = +0.008 \text{ V and } \frac{2.303RT}{F} = 0.06 \text{ V} \right)$$

Answer (4)

Sol. A: $\text{Zn} \rightarrow \text{Zn}^{2+} + 2\text{e}^-$

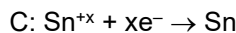

$$E_{\text{Cell}}^\circ = E_{\text{Zn}|\text{Zn}^{2+}}^\circ + E_{\text{Sn}^{+x}|\text{Sn}}^\circ$$

$$\Rightarrow 0.763 + 0.008 = 0.771 \text{ V}$$

From Nernst equation,

$$E_{\text{Cell}} = E_{\text{Cell}}^\circ - \frac{2.303 RT}{nF} \log Q$$

$$0.801 = 0.771 - \frac{0.06}{n} \log 10^{-2}$$

$$0.03 = \frac{0.06}{n} \times 2$$

$$n = 4$$

5. The half-life for the decomposition of gaseous compound A is 240 s when the gaseous pressure was 500 torr initially. When the pressure was 250 torr, the half-life was found to be 4.0 min. The order of the reaction is _____. (Nearest integer)

Answer (1)

Sol. $(t_{1/2})_A = 240 \text{ s}$ when $P = 500 \text{ torr}$

$$(t_{1/2})_A = 4 \text{ min} = 4 \times 60 = 240 \text{ sec when } P = 250 \text{ torr}$$

If means half-life is independent of concentration of reactant present.

$$\therefore \text{Order of reaction} = 1$$

6. Consider the following metal complexes:

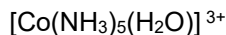

The spin-only magnetic moment value of the complex that absorbs light with shortest wavelength is _____ B.M. (Nearest integer)

Answer (0)

Sol. In all complexes, Co is present in +3 oxidation state and all complexes are low spin or inner orbital complex.

Stronger the ligand, higher the crystal field splitting.

So, order of crystal field splitting is

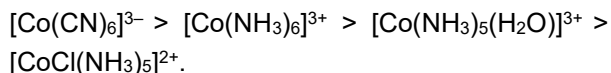

Shortest wavelength is shown by complex having maximum crystal field splitting.

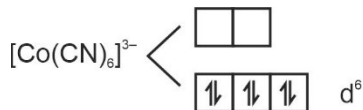

Spin only magnetic moment = $\sqrt{0(0+2)} = 0$ B.M

7. Among Co^{3+} , Ti^{2+} , V^{2+} and Cr^{2+} ions, one if used as a reagent cannot liberate H_2 from dilute mineral acid solution, its spin-only magnetic moment in gaseous state is _____ B.M. (Nearest integer)

Answer (5)

Sol. Co^{3+} will not liberate H_2 gas an reaction with dilute acid

$$E^\circ_{\text{Co}^{3+}/\text{Co}^{2+}} = +1.97$$

And Co^{3+} has electronic configuration = $[\text{Ar}] 3d^6$

\therefore 4 unpaired e^- are present in it

$$\begin{aligned} \therefore \text{Spin-only magnetic moment} &= \sqrt{4(4+2)} \\ &= 4.92 \\ &\approx 5 \end{aligned}$$

8. While estimating the nitrogen present in an organic compound by Kjeldahl's method, the ammonia evolved from 0.25 g of the compound neutralized 2.5 mL of 2 M H_2SO_4 . The percentage of nitrogen present in organic compound is _____.

Answer (56)

Sol. NH_3 gas is neutralized by 2.5 mL of 2 M H_2SO_4

$$\begin{aligned} \therefore \text{Moles of } \text{NH}_3 \text{ neutralized} &= 2.5 \times 2 \times 2 \text{ millimole} \\ &= 10 \times 10^{-3} \text{ moles} \end{aligned}$$

$$\begin{aligned} \therefore \text{Weight of N present in compound will be} &= 10 \times 10^{-3} \times 14 \\ &= 0.14 \text{ g} \end{aligned}$$

$$\begin{aligned} \therefore \% \text{ of 'N' in compound} &= \frac{0.14}{0.25} \times 100 \\ &= 56\% \end{aligned}$$

9. The number of sp^3 hybridised carbons in an acyclic neutral compound with molecular formula $\text{C}_4\text{H}_5\text{N}$ is _____.

Answer (1)

Sol. $\text{C}_4\text{H}_5\text{N}$

$$\begin{aligned} \text{DBE} &= (\text{C} + 1) - \left(\frac{\text{H} + \text{X} - \text{N}}{2} \right) \\ &= 4 + 1 - \left(\frac{5 - 1}{2} \right) = 5 - 2 = 3 \end{aligned}$$

3 double bond equivalent are present in compound

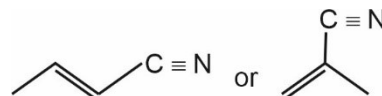

Only 1 sp^3 hybridised carbon is there

(Keeping compound as acyclic)

10. In the given reaction,

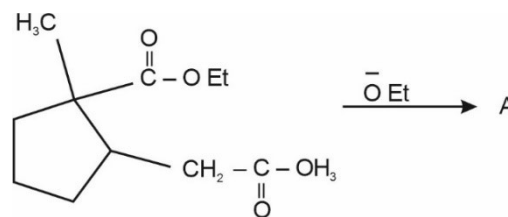

(where Et is $-\text{C}_2\text{H}_5$)

The number of chiral carbon(s) in product A is _____.

Answer (2)

Sol.

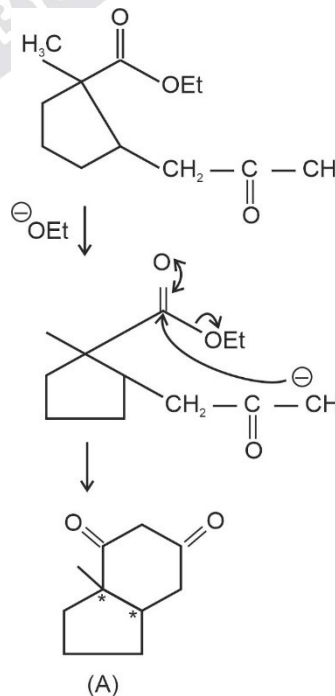

2 chiral carbons are there in product A.

MATHEMATICS

SECTION - A

Multiple Choice Questions: This section contains 20 multiple choice questions. Each question has 4 choices (1), (2), (3) and (4), out of which **ONLY ONE** is correct.

Choose the correct answer :

1. The total number of functions, $f: \{1, 2, 3, 4\} \rightarrow \{1, 2, 3, 4, 5, 6\}$ such that $f(1) + f(2) = f(3)$, is equal to
 (A) 60 (B) 90
 (C) 108 (D) 126

Answer (B)

Sol. Case 1: If $f(3) = 3$ then $f(1)$ and $f(2)$ take 1 OR 2

No. of ways = $2 \cdot 2 = 4$

Case 2: If $f(3) = 5$ then $f(1)$ and $f(2)$ take 2 OR 3 OR 1 and 4

No. of ways = $2 \cdot 2 = 4$

Case 3: If $f(3) = 2$ then $f(1) = f(2) = 1$

No. of ways = 6

Case 4: If $f(3) = 4$ then $f(1) = f(2) = 2$

No. of ways = 6

OR $f(1)$ and $f(2)$ take 1 and 3

No. of ways = 12

Case 5: If $f(3) = 6$ then $f(1) = f(2) = 3 \Rightarrow 6$ ways

OR $f(1)$ and $f(2)$ take 1 and 5 $\Rightarrow 12$ ways

OR $f(2)$ and $f(1)$ take 2 and 4 $\Rightarrow 12$ ways

2. If $\alpha, \beta, \gamma, \delta$ are the roots of the equation $x^4 + x^3 + x^2 + x + 1 = 0$, then $\alpha^{2021} + \beta^{2021} + \gamma^{2021} + \delta^{2021}$ is equal to
 (A) -4 (B) -1
 (C) 1 (D) 4

Answer (B)

Sol. $x^4 + x^3 + x^2 + x + 1 = 0$ OR $\frac{x^5 - 1}{x - 1} = 0$ ($x \neq 1$)

So roots are $e^{i2\pi/5}, e^{i4\pi/5}, e^{i6\pi/5}, e^{i8\pi/5}$

i.e. α, β, γ and δ

From properties of n^{th} root of unity

$$1^{2021} + \alpha^{2021} + \beta^{2021} + \gamma^{2021} + \delta^{2021} = 0$$

$$\Rightarrow \alpha^{2021} + \beta^{2021} + \gamma^{2021} + \delta^{2021} = -1$$

3. For $n \in \mathbb{N}$, let $S_n = \left\{ z \in \mathbb{C} : |z - 3 + 2i| = \frac{n}{4} \right\}$ and $T_n = \left\{ z \in \mathbb{C} : |z - 2 + 3i| = \frac{1}{n} \right\}$. Then the number of elements in the set $\{n \in \mathbb{N} : S_n \cap T_n = \emptyset\}$ is
 (A) 0 (B) 2
 (C) 3 (D) 4

Answer (*)

Sol. $S_n = \left\{ z \in \mathbb{C} : |z - 3 + 2i| = \frac{n}{4} \right\}$ represents a circle

with centre $C_1(3, -2)$ and radius $r_1 = \frac{n}{4}$

Similarly T_n represents circle with centre $C_2(2, -3)$

and radius $r_2 = \frac{1}{n}$

As $S_n \cap T_n = \emptyset$

$$C_1 C_2 > r_1 + r_2 \quad \text{OR} \quad C_1 C_2 < |r_1 - r_2|$$

$$\sqrt{2} > \frac{n}{4} + \frac{1}{n} \quad \text{OR} \quad \sqrt{2} < \left| \frac{n}{4} - \frac{1}{n} \right|$$

$n = 1, 2, 3, 4$

n may take infinite values

4. The number of $q \in (0, 4\pi)$ for which the system of linear equations
 $3(\sin 3\theta) x - y + z = 2$
 $3(\cos 2\theta) x + 4y + 3z = 3$
 $6x + 7y + 7z = 9$
 has no solution, is
 (A) 6
 (B) 7
 (C) 8
 (D) 9

Answer (B)

Sol. $\Delta = \begin{vmatrix} 3\sin 3\theta & -1 & 1 \\ 3\cos 2\theta & 4 & 3 \\ 6 & 7 & 7 \end{vmatrix}$

$$= 3\sin 3\theta(7) + 1(21\cos 2\theta - 18) + 1(21\cos 2\theta - 24)$$

$$\Delta = 21\sin 3\theta + 42\cos 2\theta - 42$$

For no solution

$$\sin 3\theta + 2\cos 2\theta = 2$$

$$\Rightarrow \sin 3\theta = 2 \cdot 2\sin^2 \theta$$

$$\Rightarrow 3\sin\theta - 4\sin^3\theta = 4\sin^2\theta$$

$$\Rightarrow \sin\theta(3 - 4\sin\theta - 4\sin^2\theta) = 0$$

$$\sin\theta = 0 \text{ OR } \sin\theta = \frac{1}{2}$$

$$\theta = \pi, 2\pi, 3\pi, \frac{\pi}{6}, \frac{5\pi}{6}, \frac{13\pi}{6}, \frac{17\pi}{6}$$

5. If $\lim_{n \rightarrow \infty} (\sqrt{n^2 - n - 1} + n\alpha + \beta) = 0$, then $8(\alpha + \beta)$ is equal to
- (A) 4 (B) -8
(C) -4 (D) 8

Answer (C)

Sol. $\lim_{n \rightarrow \infty} (\sqrt{n^2 - n - 1} + n\alpha + \beta) = 0$

$$= \lim_{n \rightarrow \infty} n \left[\sqrt{1 - \frac{1}{n} - \frac{1}{n^2}} + \alpha + \frac{\beta}{n} \right] = 0$$

$$\therefore \alpha = -1$$

Now,

$$\lim_{n \rightarrow \infty} n \left[\left\{ 1 - \left(\frac{1}{n} + \frac{1}{n^2} \right) \right\}^{\frac{1}{2}} + \frac{\beta}{n} - 1 \right] = 0$$

$$= \lim_{n \rightarrow \infty} \frac{\left(1 - \frac{1}{2} \left(\frac{1}{n} + \frac{1}{n^2} \right) + \dots \right) + \frac{\beta}{n} - 1}{\frac{1}{n}} = 0$$

$$\Rightarrow \beta - \frac{1}{2} = 0$$

$$\therefore \beta = \frac{1}{2}$$

$$\text{Now, } 8(\alpha + \beta) = 8 \left(-\frac{1}{2} \right) = -4$$

6. If the absolute maximum value of the function $f(x) = (x^2 - 2x + 7) e^{(4x^3 - 12x^2 - 180x + 31)}$ in the interval $[-3, 0]$ is $f(\alpha)$, then
- (A) $\alpha = 0$ (B) $\alpha = -3$
(C) $\alpha \in (-1, 0)$ (D) $\alpha \in (-3, -1]$

Answer (B)

Sol. Given, $f(x) = \underbrace{(x^2 - 2x + 7)}_{f_1(x)} \underbrace{e^{(4x^3 - 12x^2 - 180x + 31)}}_{f_2(x)}$

$$f_1(x) = x^2 - 2x + 7$$

$$f_1'(x) = 2x - 2, \text{ so } f(x) \text{ is decreasing in } [-3, 0]$$

and positive also

$$f_2(x) = e^{4x^3 - 12x^2 - 180x + 31}$$

$$f_2'(x) = e^{4x^3 - 12x^2 - 180x + 31} \cdot (12x^2 - 24x - 180)$$

$$= 12(x - 5)(x + 3) e^{4x^3 - 12x^2 - 180x + 31}$$

So, $f_2(x)$ is also decreasing and positive in $[-3, 0]$

\therefore absolute maximum value of $f(x)$ occurs at $x = -3$

$$\therefore \boxed{\alpha = -3}$$

7. The curve $y(x) = ax^3 + bx^2 + cx + 5$ touches the x -axis at the point $P(-2, 0)$ and cuts the y -axis at the point Q , where y is equal to 3. Then the local maximum value of $y(x)$ is

- (A) $\frac{27}{4}$ (B) $\frac{29}{4}$
(C) $\frac{37}{4}$ (D) $\frac{9}{2}$

Answer (A)

Sol. $f(x) = y = ax^3 + bx^2 + cx + 5 \dots(i)$

$$\frac{dy}{dx} = 3ax^2 + 2bx + c \dots(ii)$$

Touches x -axis at $P(-2, 0)$

$$\Rightarrow y|_{x=-2} = 0 \Rightarrow -8a + 4b - 2c + 5 = 0 \dots(iii)$$

Touches x -axis at $P(-2, 0)$ also implies

$$\frac{dy}{dx}|_{x=-2} = 0 \Rightarrow 12a - 4b + c = 0 \dots(iv)$$

$y = f(x)$ cuts y -axis at $(0, 5)$

$$\text{Given, } \frac{dy}{dx}|_{x=0} = c = 3 \dots(v)$$

From (iii), (iv) and (v)

$$a = -\frac{1}{2}, b = -\frac{3}{4}, c = 3$$

$$\Rightarrow f(x) = \frac{-x^3}{2} - \frac{3}{4}x^2 + 3x + 5$$

$$f'(x) = \frac{-3}{2}x^2 - \frac{3}{2}x + 3$$

$$= \frac{-3}{2}(x + 2)(x - 1)$$

$$f'(x) = 0 \text{ at } x = -2 \text{ and } x = 1$$

By first derivative test $x = 1$ in point of local maximum

Hence local maximum value of $f(x)$ is $f(1)$

$$\text{i.e., } \frac{27}{4}$$

8. The area of the region given by

$$A = \{(x, y); x^2 \leq y \leq \min\{x+2, 4-3x\}\}$$

- (A) $\frac{31}{8}$ (B) $\frac{17}{6}$
 (C) $\frac{19}{6}$ (D) $\frac{27}{8}$

Answer (B)

Sol. $A = \{(x, y) : x^2 \leq y \leq \min\{x+2, 4-3x\}\}$

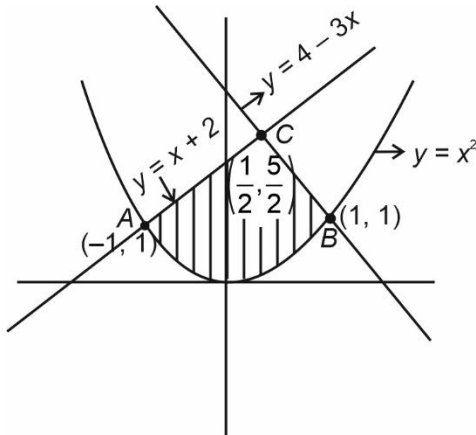

So area of required region

$$A = \int_{-1}^{\frac{1}{2}} (x+2-x^2) dx + \int_{\frac{1}{2}}^1 (4-3x-x^2) dx$$

$$= \left[\frac{x^2}{2} + 2x - \frac{x^3}{3} \right]_{-1}^{\frac{1}{2}} + \left[4x - \frac{3x^2}{2} - \frac{x^3}{3} \right]_{\frac{1}{2}}^1$$

$$= \left(\frac{1}{8} + 1 - \frac{1}{24} \right) - \left(\frac{1}{2} - 2 + \frac{1}{3} \right) + \left(4 - \frac{3}{2} - \frac{1}{3} \right) - \left(2 - \frac{3}{8} - \frac{1}{24} \right)$$

$$= \frac{17}{6}$$

9. For any real number x , let $[x]$ denote the largest integer less than equal to x . Let f be a real valued function defined on the interval $[-10, 10]$ by

$$f(x) = \begin{cases} x - [x], & \text{if } [x] \text{ is odd} \\ 1 + [x] - x, & \text{if } [x] \text{ is even.} \end{cases}$$

Then the value of $\frac{\pi^2}{10} \int_{-10}^{10} f(x) \cos \pi x dx$ is

- (A) 4 (B) 2
 (C) 1 (D) 0

Answer (A)

Sol. $f(x) = \begin{cases} x - [x], & \text{if } [x] \text{ is odd} \\ 1 + [x] - x, & \text{if } [x] \text{ is even} \end{cases}$

Graph of $f(x)$

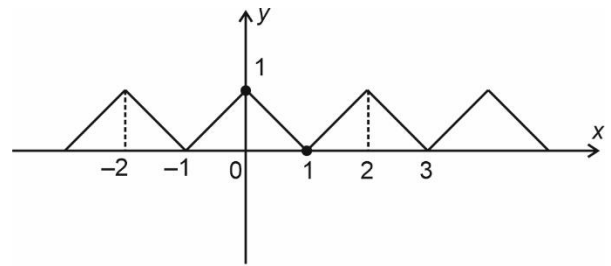

$f(x)$ is an even and periodic function

$$\text{So, } \frac{\pi^2}{10} \int_{-10}^{10} f(x) \cos \pi x dx = \frac{\pi^2}{10} \cdot 20 \int_0^1 f(x) \cos \pi x dx$$

$$= 2\pi^2 \int_0^1 (1-x) \cos \pi x dx$$

$$= 2\pi^2 \left\{ (1-x) \frac{\sin \pi x}{\pi} \Big|_0^1 - \frac{\cos \pi x}{\pi^2} \Big|_0^1 \right\} = 4$$

10. The slope of the tangent to a curve $C : y = y(x)$ at any point (x, y) on it is $\frac{2e^{2x} - 6e^{-x} + 9}{2 + 9e^{-2x}}$. If C passes through the points

$\left(0, \frac{1}{2} + \frac{\pi}{2\sqrt{2}}\right)$ and $\left(\alpha, \frac{1}{2} e^{2\alpha}\right)$, then e^α is equal to

- (A) $\frac{3+\sqrt{2}}{3-\sqrt{2}}$ (B) $\frac{3}{\sqrt{2}} \left(\frac{3+\sqrt{2}}{3-\sqrt{2}} \right)$
 (C) $\frac{1}{\sqrt{2}} \left(\frac{\sqrt{2}+1}{\sqrt{2}-1} \right)$ (D) $\frac{\sqrt{2}+1}{\sqrt{2}-1}$

Answer (B)

Sol. $\frac{dy}{dx} = \frac{2e^{2x} - 6e^{-x} + 9}{2 + 9e^{-2x}} = e^{2x} - \frac{6e^{-x}}{2 + 9e^{-2x}}$

$$\int dy = \int e^{2x} dx - 3 \int \frac{e^{-x}}{1 + \left(\frac{3e^{-x}}{\sqrt{2}}\right)^2} dx$$

put $e^{-x} = t$

$$= \frac{e^{2x}}{2} + 3 \int \frac{dt}{1 + \left(\frac{3t}{\sqrt{2}}\right)^2}$$

$$= \frac{e^{2x}}{2} + \sqrt{2} \tan^{-1} \frac{3t}{\sqrt{2}} + C$$

$$y = \frac{e^{2x}}{2} + \sqrt{2} \tan^{-1} \left(\frac{3e^{-x}}{\sqrt{2}} \right) + C$$

It is given that the curve passes through

$$\left(0, \frac{1}{2} + \frac{\pi}{2\sqrt{2}} \right)$$

$$\frac{1}{2} + \frac{\pi}{2\sqrt{2}} = \frac{1}{2} + \sqrt{2} \tan^{-1} \left(\frac{3}{\sqrt{2}} \right) + C$$

$$\Rightarrow C = \frac{\pi}{2\sqrt{2}} - \sqrt{2} \tan^{-1} \left(\frac{3}{\sqrt{2}} \right)$$

Now if $\left(\alpha, \frac{1}{2} e^{2\alpha} \right)$ satisfies the curve, then

$$\frac{1}{2} e^{2\alpha} = \frac{e^{2\alpha}}{2} + \sqrt{2} \tan^{-1} \left(\frac{3e^{-\alpha}}{\sqrt{2}} \right) + \frac{\pi}{2\sqrt{2}} - \sqrt{2} \tan^{-1} \left(\frac{3}{\sqrt{2}} \right)$$

$$\tan^{-1} \left(\frac{3}{\sqrt{2}} \right) - \tan^{-1} \left(\frac{3e^{-\alpha}}{\sqrt{2}} \right) = \frac{\pi}{2\sqrt{2}} \times \frac{1}{\sqrt{2}} = \frac{\pi}{4}$$

$$\frac{\frac{3}{\sqrt{2}} - \frac{3e^{-\alpha}}{\sqrt{2}}}{1 + \frac{9}{2} e^{-\alpha}} = 1$$

$$\frac{3}{\sqrt{2}} e^{\alpha} - \frac{3}{\sqrt{2}} = e^{\alpha} + \frac{9}{2}$$

$$e^{\alpha} = \frac{\frac{9}{2} + \frac{3}{\sqrt{2}}}{\frac{3}{\sqrt{2}} - 1} = \frac{3}{\sqrt{2}} \left(\frac{3 + \sqrt{2}}{3 - \sqrt{2}} \right)$$

11. The general solution of the differential equation $(x - y^2)dx + y(5x + y^2)dy = 0$ is :

(A) $(y^2 + x)^4 = C(y^2 + 2x)^3$

(B) $(y^2 + 2x)^4 = C(y^2 + x)^3$

(C) $\left| (y^2 + x)^3 \right| = C(2y^2 + x)^4$

(D) $\left| (y^2 + 2x)^3 \right| = C(2y^2 + x)^4$

Answer (A)

Sol. $(x - y^2)dx + y(5x + y^2)dy = 0$

$$y \frac{dy}{dx} = \frac{y^2 - x}{5x + y^2}$$

Let $y^2 = t$

$$\frac{1}{2} \cdot \frac{dt}{dx} = \frac{t - x}{5x + t}$$

Now substitute, $t = vx$

$$\frac{dt}{dx} = v + x \frac{dv}{dx}$$

$$\frac{1}{2} \left\{ v + x \frac{dv}{dx} \right\} = \frac{v - 1}{5 + v}$$

$$x \frac{dv}{dx} = \frac{2v - 2}{5 + v} - v = \frac{-3v - v^2 - 2}{5 + v}$$

$$\int \frac{5 + v}{v^2 + 3v + 2} dv = \int -\frac{dx}{x}$$

$$\int \frac{4}{v+1} dv - \int \frac{3}{v+2} dv = -\int \frac{dx}{x}$$

$$4 \ln|v+1| - 3 \ln|v+2| = -\ln x + \ln C$$

$$\left| \frac{(v+1)^4}{(v+2)^3} \right| = \frac{C}{x}$$

$$\left| \frac{\left(\frac{y^2}{x} + 1 \right)^4}{\left(\frac{y^2}{x} + 2 \right)^3} \right| = \frac{C}{x}$$

$$\left| (y^2 + x)^4 \right| = C \left| (y^2 + 2x)^3 \right|$$

12. A line, with the slope greater than one, passes through the point $A(4, 3)$ and intersects the line $x - y - 2 = 0$ at the point B . If the length of the line segment AB is $\frac{\sqrt{29}}{3}$, then B also lies on the line :

(A) $2x + y = 9$

(B) $3x - 2y = 7$

(C) $x + 2y = 6$

(D) $2x - 3y = 3$

Answer (C)

Sol.

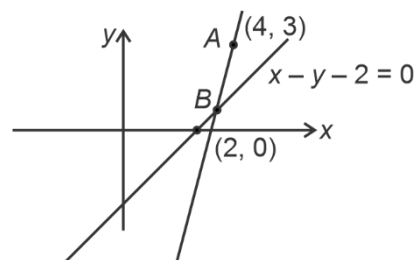

Let inclination of required line is θ ,

So the coordinates of point B can be assumed as

$$\left(4 - \frac{\sqrt{29}}{3} \cos \theta, 3 - \frac{\sqrt{29}}{3} \sin \theta \right)$$

Which satisfies $x - y - 2 = 0$

$$4 - \frac{\sqrt{29}}{3} \cos \theta - 3 + \frac{\sqrt{29}}{3} \sin \theta - 2 = 0$$

$$\sin \theta - \cos \theta = \frac{3}{\sqrt{29}}$$

By squaring

$$\sin 2\theta = \frac{20}{29} = \frac{2 \tan \theta}{1 + \tan^2 \theta}$$

$\tan \theta = \frac{5}{2}$ only (because slope is greater than 1)

$$\sin \theta = \frac{5}{\sqrt{29}}, \cos \theta = \frac{2}{\sqrt{29}}$$

Point $B: \left(\frac{10}{3}, \frac{4}{3} \right)$

Which also satisfies $x + 2y = 6$

13. Let the locus of the centre (α, β) , $\beta > 0$, of the circle which touches the circle $x^2 + (y - 1)^2 = 1$ externally and also touches the x-axis be L . Then the area bounded by L and the line $y = 4$ is :

- (A) $\frac{32\sqrt{2}}{3}$
 (B) $\frac{40\sqrt{2}}{3}$
 (C) $\frac{64}{3}$
 (D) $\frac{32}{3}$

Answer (C)

Sol.

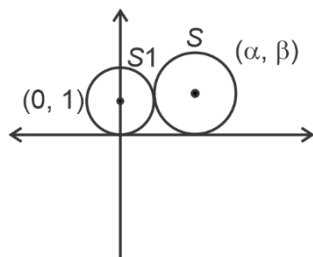

Radius of circle S touching x-axis and centre (α, β) is $|\beta|$. According to given conditions

$$\alpha^2 + (\beta - 1)^2 = (|\beta| + 1)^2$$

$$\alpha^2 + \beta^2 - 2\beta + 1 = \beta^2 + 1 + 2|\beta|$$

$$\alpha^2 = 4\beta \text{ as } \beta > 0$$

\therefore Required locus is $L: x^2 = 4y$

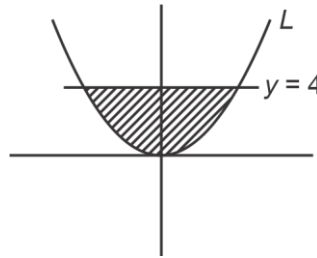

The area of shaded region $= 2 \int_0^4 2\sqrt{y} dy$

$$= 4 \cdot \left[\frac{3}{2} y^{\frac{3}{2}} \right]_0^4$$

$$= \frac{64}{3} \text{ square units.}$$

14. Let P be the plane containing the straight line $\frac{x-3}{9} = \frac{y+4}{-1} = \frac{z-7}{-5}$ and perpendicular to the

plane containing the straight lines $\frac{x}{2} = \frac{y}{3} = \frac{z}{5}$ and

$\frac{x}{3} = \frac{y}{7} = \frac{z}{8}$. If d is the distance P from the point

$(2, -5, 11)$, then d^2 is equal to :

- (A) $\frac{147}{2}$ (B) 96
 (C) $\frac{32}{3}$ (D) 54

Answer (C*)

Sol. Let $\langle a, b, c \rangle$ be direction ratios of plane containing

lines $\frac{x}{2} = \frac{y}{3} = \frac{z}{5}$ and $\frac{x}{3} = \frac{y}{7} = \frac{z}{8}$.

$$\therefore 2a + 3b + 5c = 0 \quad \dots(i)$$

$$\text{and } 3a + 7b + 8c = 0 \quad \dots(ii)$$

$$\text{from eq. (i) and (ii) : } \frac{a}{24-35} = \frac{b}{15-16} = \frac{c}{14-9}$$

\therefore D.R^s of plane are $\langle 11, 1, -5 \rangle$

Let D.R^s of plane P be $\langle a_1, b_1, c_1 \rangle$ then.

$$11a_1 + b_1 - 5c_1 = 0 \quad \dots(iii)$$

$$\text{and } 9a_1 - b_1 - 5c_1 = 0 \quad \dots(iv)$$

From eq. (iii) and (iv) :

$$\frac{a_1}{-5-5} = \frac{b_1}{-45+55} = \frac{c_1}{-11-9}$$

\therefore D.A^s of plane P are $\langle 1, -1, 2 \rangle$

Equation plane P is : $1(x-3) - 1(y+4) + 2(z-7) = 0$
 $\Rightarrow x - y + 2z - 21 = 0$

Distance from point $(2, -5, 11)$ is $d = \frac{|2+5+22-21|}{\sqrt{6}}$

$\therefore d^2 = \frac{32}{3}$

15. Let ABC be a triangle such that $\vec{BC} = \vec{a}, \vec{CA} = \vec{b}, \vec{AB} = \vec{c}, |\vec{a}| = 6\sqrt{2}, |\vec{b}| = 2\sqrt{3}$ and $\vec{b} \cdot \vec{c} = 12$. Consider the statements :

(S1) : $|\vec{a} \times \vec{b} + \vec{c} \times \vec{b}| - |\vec{c}| = 6(2\sqrt{2} - 1)$

(S2) : $\angle ACB = \cos^{-1}\left(\sqrt{\frac{2}{3}}\right)$

Then

- (A) Both (S1) and (S2) are true
- (B) Only (S1) is true
- (C) Only (S2) is true
- (D) Both (S1) and (S2) are false

Answer (C*)

Sol.

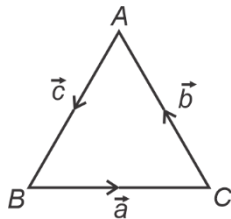

$\therefore \vec{a} + \vec{b} + \vec{c} = 0$... (i)

then $\vec{a} + \vec{c} = -\vec{b}$

then $(\vec{a} + \vec{c}) \times \vec{b} = -\vec{b} \times \vec{b}$

$\therefore \vec{a} \times \vec{b} + \vec{c} \times \vec{b} = \vec{0}$... (i)

For (S1) : $|\vec{a} \times \vec{b} + \vec{c} \times \vec{b}| - |\vec{c}| = 6(2\sqrt{2} - 1)$

$|\vec{a} + \vec{c}| \times |\vec{b}| - |\vec{c}| = 6(2\sqrt{2} - 1)$

$|\vec{c}| = 6 - 12\sqrt{2}$ (not possible)

Hence (S1) is not correct

For (S2) : from (i) $\vec{b} + \vec{c} = -\vec{a}$

$\Rightarrow \vec{b} \cdot \vec{b} + \vec{c} \cdot \vec{b} = -\vec{a} \cdot \vec{b}$

$\Rightarrow 12 + 12 = -6\sqrt{2} \cdot 2\sqrt{3} \cos(\pi - \angle ACB)$

$\therefore \cos(\angle ACB) = \sqrt{\frac{2}{3}}$

$\therefore \angle ACB = \cos^{-1}\sqrt{\frac{2}{3}}$

\therefore (S2) is correct.

16. If the sum and the product of mean and variance of a binomial distribution are 24 and 128 respectively, then the probability of one or two successes is :

- (A) $\frac{33}{2^{32}}$
- (B) $\frac{33}{2^{29}}$
- (C) $\frac{33}{2^{28}}$
- (D) $\frac{33}{2^{27}}$

Answer (C)

Sol. If n is number of trials, p is probability of success and q is probability of unsuccess then,

Mean = np and variance = npq .

Here $np + npq = 24$... (i)

$np \cdot npq = 128$... (ii)

and $q = 1 - p$... (iii)

from eq. (i), (ii) and (iii) : $p = q = \frac{1}{2}$ and $n = 32$.

\therefore Required probability = $p(X = 1) + p(X = 2)$

$$= {}^{32}C_1 \cdot \left(\frac{1}{2}\right)^{32} + {}^{32}C_2 \cdot \left(\frac{1}{2}\right)^{32}$$

$$= \left(32 + \frac{32 \times 31}{2}\right) \cdot \frac{1}{2^{32}}$$

$$= \frac{33}{2^{28}}$$

17. If the numbers appeared on the two throws of a fair six faced die are α and β , then the probability that $x^2 + \alpha x + \beta > 0$, for all $x \in R$, is :

- (A) $\frac{17}{36}$
- (B) $\frac{4}{9}$
- (C) $\frac{1}{2}$
- (D) $\frac{19}{36}$

Answer (A)

Sol. For $x^2 + \alpha x + \beta > 0 \forall x \in R$ to hold, we should have $\alpha^2 - 4\beta < 0$

If $\alpha = 1$, β can be 1, 2, 3, 4, 5, 6 i.e., 6 choices

If $\alpha = 2$, β can be 2, 3, 4, 5, 6 i.e., 5 choices

If $\alpha = 3$, β can be 3, 4, 5, 6 i.e., 4 choices

If $\alpha = 4$, β can be 5 or 6 i.e., 2 choices

If $\alpha = 6$, No possible value for β i.e., 0 choices

1. Let $A = \begin{pmatrix} 2 & -1 & -1 \\ 1 & 0 & -1 \\ 1 & -1 & 0 \end{pmatrix}$ and $B = A - I$. If $\omega = \frac{\sqrt{3}i - 1}{2}$,

then the number of elements in the set $\{n \in \{1, 2, \dots, 100\} : A^n + (\omega B)^n = A + B\}$ is equal to _____.

Answer (17)

Sol. Here $A = \begin{pmatrix} 2 & -1 & -1 \\ 1 & 0 & -1 \\ 1 & -1 & 0 \end{pmatrix}$

We get $A^2 = A$ and similarly for

$$B = A - I = \begin{bmatrix} 1 & -1 & -1 \\ 1 & -1 & -1 \\ 1 & -1 & -1 \end{bmatrix}$$

We get $B^2 = -B \Rightarrow B^3 = B$

$$\therefore A^n + (\omega B)^n = A + (\omega B)^n \text{ for } n \in \mathbb{N}$$

For ω^n to be unity n shall be multiple of 3 and for B^n to be B , n shall be 3, 5, 7, ... 99

$$\therefore n = \{3, 9, 15, \dots, 99\}$$

Number of elements = 17.

2. The letters of the word 'MANKIND' are written in all possible orders and arranged in serial order as in an English dictionary. Then the serial number of the word 'MANKIND' is _____.

Answer (1492)

Sol. Arranging letter in alphabetical order A D I K M N N for finding rank of MANKIND making arrangements of dictionary we get

$$A \dots \rightarrow \frac{6!}{2!} = 360$$

$$D \dots \rightarrow 360$$

$$I \dots \rightarrow 360$$

$$K \dots \rightarrow 360$$

$$M A D \dots \rightarrow \frac{4!}{2!} = 12$$

$$M A I \dots \rightarrow 12$$

$$M A K \dots \rightarrow 12$$

$$M A N D \dots \rightarrow 3! = 6$$

$$M A N I \dots \rightarrow 6$$

$$M A N K D \dots \rightarrow 2$$

$$M A N K I D \dots \rightarrow 1$$

$$M A N K I N D \dots \rightarrow 1$$

$$\therefore \text{Rank of MANKIND} = 1440 + 36 + 12 + 2 + 2 = 1492$$

3. If the maximum value of the term independent of t in the expansion of $\left(t^2 x^{\frac{1}{5}} + \frac{(1-x)^{\frac{1}{10}}}{t}\right), x \geq 0$ is K , then $8K$ is equal to _____.

Answer (6006)

Sol. General Term = ${}^{15}C_r \left(t^2 x^{\frac{1}{5}}\right)^{15-r} \left(\frac{(1-x)^{\frac{1}{10}}}{t}\right)^r$

for term independent on t

$$2(15-r) - r = 0$$

$$\Rightarrow r = 10$$

$$\therefore T_{11} = {}^{15}C_{10} x(1-x)$$

Maximum value of $x(1-x)$ occur at $x = \frac{1}{2}$

$$\text{i.e., } (x(1-x))_{\max} = \frac{1}{4}$$

$$\Rightarrow K = {}^{15}C_{10} \times \frac{1}{4}$$

$$\Rightarrow 8K = 2({}^{15}C_{10}) = 6006$$

4. Let a, b be two non-zero real numbers. If p and r are the roots of the equation $x^2 - 8ax + 2a = 0$ and q and s are the roots of the equation $x^2 + 12bx + 6b = 0$, such that $\frac{1}{p}, \frac{1}{q}, \frac{1}{r}, \frac{1}{s}$ are in A.P., then $a^{-1} - b^{-1}$ is equal to _____.

Answer (38)

Sol. \therefore Roots of $2ax^2 - 8ax + 1 = 0$ are $\frac{1}{p}$ and $\frac{1}{r}$ and

roots of $6bx^2 + 12bx + 1 = 0$ are $\frac{1}{q}$ and $\frac{1}{s}$.

Let $\frac{1}{p}, \frac{1}{q}, \frac{1}{r}, \frac{1}{s}$ as $\alpha - 3\beta, \alpha - \beta, \alpha + \beta, \alpha + 3\beta$

So sum of roots $2\alpha - 2\beta = 4$ and $2\alpha + 2\beta = -2$

Clearly $\alpha = \frac{1}{2}$ and $\beta = -\frac{3}{2}$

Now product of roots, $\frac{1}{p} \cdot \frac{1}{r} = \frac{1}{2a} = -5 \Rightarrow \frac{1}{a} = -10$

and $\frac{1}{q} \cdot \frac{1}{x} = \frac{1}{6b} = -8 \Rightarrow \frac{1}{b} = -48$

So, $\frac{1}{a} - \frac{1}{b} = 38$

5. Let $a_1 = b_1 = 1$, $a_n = a_{n-1} + 2$ and $b_n = a_n + b_{n-1}$ for every natural number $n \geq 2$. Then $\sum_{n=1}^{15} a_n \cdot b_n$ is equal to _____.

Answer (27560)

Sol. $a_1 = b_1 = 1$

$a_n = a_{n-1} + 2$ (for $n \geq 2$) $b_n = a_n + b_{n-1}$

$a_2 = a_1 + 2 = 1 + 2 = 3$ $b_2 = a_2 + b_1 = 3 + 1 = 4$

$a_3 = a_2 + 2 = 3 + 2 = 5$ $b_3 = a_3 + b_2 = 5 + 4 = 9$

$a_4 = a_3 + 2 = 5 + 2 = 7$ $b_4 = a_4 + b_3 = 7 + 9 = 16$

$a_{15} = a_{14} + 2 = 29$ $b_{15} = 225$

$\sum_{n=1}^{15} a_n b_n = 1 \times 1 + 3 \times 4 + 5 \times 9 + \dots + 29 \times 225$

$\therefore \sum_{n=1}^{11} a_n b_n = \sum_{n=1}^{15} (2n-1)n^2 = \sum_{n=1}^{15} 2n^3 - \sum_{n=1}^{15} n^2$
 $= 2 \left[\frac{15 \times 16}{2} \right]^2 - \left[\frac{15 \times 16 \times 31}{6} \right] = 27560.$

6. Let $f(x) = \begin{cases} \lfloor 4x^2 - 8x + 5 \rfloor, & \text{if } 8x^2 - 6x + 1 \geq 0 \\ \lceil 4x^2 - 8x + 5 \rceil, & \text{if } 8x^2 - 6x + 1 < 0 \end{cases}$

where $\lfloor \alpha \rfloor$ denotes the greatest integer less than or equal to α . Then the number of points in \mathbf{R} where f is not differentiable is

Answer (3)

Sol. $f(x) = \begin{cases} \lfloor 4x^2 - 8x + 5 \rfloor, & \text{if } 8x^2 - 6x + 1 \geq 0 \\ \lceil 4x^2 - 8x + 5 \rceil, & \text{if } 8x^2 - 6x + 1 < 0 \end{cases}$

$= \begin{cases} 4x^2 - 8x + 5, & \text{if } x \in \left[-\infty, \frac{1}{4}\right] \cup \left[\frac{1}{2}, \infty\right) \\ \lceil 4x^2 - 8x + 5 \rceil & \text{if } x \in \left(\frac{1}{4}, \frac{1}{2}\right) \end{cases}$

$$f(x) = \begin{cases} 4x^2 - 8x + 5 & \text{if } x \in \left(-\infty, \frac{1}{4}\right] \cup \left[\frac{1}{2}, \infty\right) \\ 3 & \text{if } x \in \left(\frac{1}{4}, \frac{2-\sqrt{2}}{2}\right) \\ 2 & \text{if } x \in \left(\frac{2-\sqrt{2}}{2}, \frac{1}{2}\right) \end{cases}$$

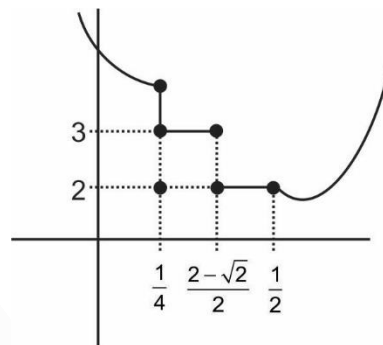

\therefore Non-diff at $x = \frac{1}{4}, \frac{2-\sqrt{2}}{2}, \frac{1}{2}$

7. If $\lim_{n \rightarrow \infty} \frac{(n+1)^{k-1}}{n^{k+1}} [(nk+1) + (nk+2) + \dots + (nk+n)] = 33 \cdot \lim_{n \rightarrow \infty} \frac{1}{n^{k+1}} [1^k + 2^k + 3^k + \dots + n^k]$, then the integral value of k is equal to _____.

Answer (5)

Sol. $\lim_{n \rightarrow \infty} \left(\frac{n+1}{n}\right)^{k-1} \frac{1}{n} \sum_{r=1}^n \left(k + \frac{r}{n}\right) = 33 \lim_{n \rightarrow \infty} \frac{1}{n} \sum_{k=1}^n \left(\frac{r}{n}\right)^k$
 $\Rightarrow \int_0^1 (k+x) dx = 33 \int_0^1 x^k dx$
 $\Rightarrow \frac{2k+1}{2} = \frac{33}{k+1}$
 $\Rightarrow k = 5$

8. Let the equation of two diameters of a circle $x^2 + y^2 - 2x + 2fy + 1 = 0$ be $2px - y = 1$ and $2x + py = 4p$. Then the slope $m \in (0, \infty)$ of the tangent to the hyperbola $3x^2 - y^2 = 3$ passing through the centre of the circle is equal to _____.

Answer (2)

Sol. $x^2 + y^2 - 2x + 2fy + 1 = 0$ [entre = $(1, -f)$]
 Diameter $2px - y = 1$... (i)
 $2x + py = 4p$... (ii)

$x = \frac{5P}{2P^2 + 2}$ $y = \frac{4P^2 - 1}{1 + P^2}$

$\therefore x = 1$ $f = 0$ [for $P = \frac{1}{2}$]

$$\frac{5P}{2P^2 + 2} = 1 \quad f = 3 \quad [\text{for } P = 2]$$

$$\therefore P = \frac{1}{2}, 2$$

Centre can be $(\frac{1}{2}, 0)$ or $(1, 3)$

$(\frac{1}{2}, 0)$ will not satisfy

\therefore Tangent should pass through $(2, 3)$ for $3x^2 - y^2 = 3$

$$\frac{x^2}{1} - \frac{y^2}{3} = 1$$

$$y = mx \pm \sqrt{m^2 - 3}$$

substitute $(2, 3)$

$$3 = m \pm \sqrt{m^2 - 3}$$

$$\therefore \boxed{m = 2}$$

9. The sum of diameters of the circles that touch (i) the parabola $75x^2 = 64(5y - 3)$ at the point $(\frac{8}{5}, \frac{6}{5})$ and (ii) the y -axis, is equal to _____.

Answer (10)

Sol.

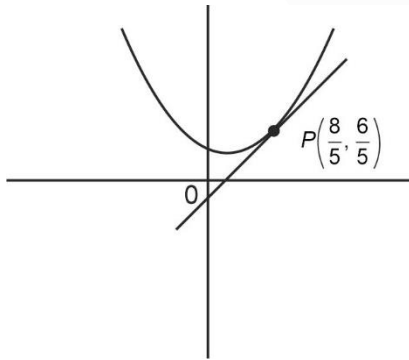

Equation of tangent to the parabola at $P(\frac{8}{5}, \frac{6}{5})$

$$75x \cdot \frac{8}{5} = 160 \left(y + \frac{6}{5} \right) - 192$$

$$\Rightarrow 120x = 160y$$

$$\Rightarrow 3x = 4y$$

Equation of circle touching the given parabola at P can be taken as

$$\left(x - \frac{8}{5} \right)^2 + \left(y - \frac{6}{5} \right)^2 + \lambda(3x - 4y) = 0$$

If this circle touches y -axis then

$$\frac{64}{25} + \left(y - \frac{6}{5} \right)^2 + \lambda(-4y) = 0$$

$$\Rightarrow y^2 - 2y \left(2\lambda + \frac{6}{5} \right) + 4 = 0$$

$$\Rightarrow D = 0$$

$$\Rightarrow \left(2\lambda + \frac{6}{5} \right)^2 = 4$$

$$\Rightarrow \lambda = \frac{2}{5} \text{ or } -\frac{8}{5}$$

Radius = 1 or 4

Sum of diameter = 10

10. The line of shortest distance between the lines $\frac{x-2}{0} = \frac{y-1}{1} = \frac{z}{1}$ and $\frac{x-3}{2} = \frac{y-5}{2} = \frac{z-1}{1}$ makes an angle of $\cos^{-1} \left(\frac{\sqrt{2}}{\sqrt{27}} \right)$ with the plane $P : ax - y - z = 0$, ($a > 0$). If the image of the point $(1, 1, -5)$ in the plane P is (α, β, γ) , then $\alpha + \beta - \gamma$ is equal to _____.

Answer (*)

Sol. Line of shortest distance will be along $\vec{b}_1 \times \vec{b}_2$

Where, $\vec{b}_1 = \hat{j} + \hat{k}$ and $\vec{b}_2 = 2\hat{i} + 2\hat{j} + \hat{k}$

$$\vec{b}_1 \times \vec{b}_2 = \begin{vmatrix} \hat{i} & \hat{j} & \hat{k} \\ 0 & 1 & 1 \\ 2 & 2 & 1 \end{vmatrix} = -\hat{i} + 2\hat{j} - 2\hat{k}$$

Angle between $\vec{b}_1 \times \vec{b}_2$ and plane P ,

$$\sin \theta = \frac{|-a - 2 + 2|}{3 \cdot \sqrt{a^2 + 2}} = \frac{5}{\sqrt{27}} \Rightarrow \frac{|a|}{\sqrt{a^2 + 2}} = \frac{5}{\sqrt{3}}$$

$$\Rightarrow a^2 = -\frac{25}{11} \text{ (not possible)}$$

