

27/07/2022

Evening



Corporate Office : Aakash Tower, 8, Pusa Road, New Delhi-110005 | Ph.: 011-47623456

## Answers & Solutions

Time : 3 hrs.

*for*

M.M. : 300

## JEE (Main)-2022 (Online) Phase-2

(Physics, Chemistry and Mathematics)

### IMPORTANT INSTRUCTIONS:

- (1) The test is of **3 hours** duration.
- (2) The Test Booklet consists of 90 questions. The maximum marks are 300.
- (3) There are **three** parts in the question paper consisting of **Physics, Chemistry** and **Mathematics** having 30 questions in each part of equal weightage. Each part (subject) has two sections.
  - (i) **Section-A:** This section contains 20 multiple choice questions which have only one correct answer. Each question carries **4 marks** for correct answer and **-1 mark** for wrong answer.
  - (ii) **Section-B:** This section contains 10 questions. In Section-B, attempt any **five questions out of 10**. The answer to each of the questions is a numerical value. Each question carries **4 marks** for correct answer and **-1 mark** for wrong answer. For Section-B, the answer should be rounded off to the nearest integer.

**PHYSICS**

**SECTION - A**

**Multiple Choice Questions:** This section contains 20 multiple choice questions. Each question has 4 choices (1), (2), (3) and (4), out of which **ONLY ONE** is correct.

**Choose the correct answer :**

1. An expression of energy density is given by  $u = \frac{\alpha}{\beta} \sin\left(\frac{\alpha x}{kt}\right)$ , where  $\alpha$ ,  $\beta$  are constants,  $x$  is displacement,  $k$  is Boltzmann constant and  $t$  is the temperature. The dimensions of  $\beta$  will be

- (A)  $[ML^2T^{-2}\theta^{-1}]$       (B)  $[M^0L^2T^{-2}]$   
(C)  $[M^0L^0T^0]$       (D)  $[M^0L^2T^0]$

**Answer (D)**

**Sol.**  $u = \frac{\alpha}{\beta} \sin\left(\frac{\alpha x}{kt}\right)$

$$[\alpha] = \left[\frac{kt}{x}\right] = \frac{[\text{Energy}]}{[\text{Distance}]}$$

$$[\beta] = \frac{[\alpha]}{[u]}$$

$$= \frac{[\text{Energy}]/[\text{Distance}]}{[\text{Energy}]/[\text{Volume}]}$$

$$= [L^2]$$

2. A body of mass 10 kg is projected at an angle of  $45^\circ$  with the horizontal. The trajectory of the body is observed to pass through a point (20, 10). If  $T$  is the time of flight, then its momentum vector, at time

$$t = \frac{T}{\sqrt{2}}, \text{ is } \underline{\hspace{2cm}}. [\text{Take } g = 10 \text{ m/s}^2]$$

- (A)  $100\hat{i} + (100\sqrt{2} - 200)\hat{j}$   
(B)  $100\sqrt{2}\hat{i} + (100 - 200\sqrt{2})\hat{j}$   
(C)  $100\hat{i} + (100 - 200\sqrt{2})\hat{j}$   
(D)  $100\sqrt{2}\hat{i} + (100\sqrt{2} - 200)\hat{j}$

**Answer (D)**

**Sol.**  $m = 10 \text{ kg}$

$$\theta = 45^\circ$$

$$y = x \tan\theta \left(1 - \frac{x}{R}\right)$$

$$\Rightarrow 10 = 20 \left(1 - \frac{20}{R}\right)$$

$$\Rightarrow R = 40$$

$$40 = \frac{u^2}{10} \Rightarrow u = 20$$

$$\Rightarrow T = \frac{2 \times 20 \times \frac{1}{\sqrt{2}}}{10} = \frac{4}{\sqrt{2}} \text{ s} \Rightarrow t = 2 \text{ s}$$

$$\text{at } t = 2, \vec{v} = (10\sqrt{2}\hat{i}) + (10\sqrt{2} - 2 \times 10)\hat{j}$$

$$\Rightarrow \vec{p} = 10 [10\sqrt{2}\hat{i} + (10\sqrt{2} - 20)\hat{j}]$$

$$= 100\sqrt{2}\hat{i} + (100\sqrt{2} - 200)\hat{j}$$

3. A block of mass  $M$  slides down on a rough inclined plane with constant velocity. The angle made by the incline plane with horizontal is  $\theta$ . The magnitude of the contact force will be

- (A)  $Mg$       (B)  $Mg \cos\theta$   
(C)  $\sqrt{Mg \sin\theta + Mg \cos\theta}$       (D)  $Mg \sin\theta \sqrt{1 + \mu}$

**Answer (A)**

**Sol.** As the body is moving with constant velocity so forces acting on the body must be balanced.

$\Rightarrow$  Contact force from incline should balance weight of the body.

$$\Rightarrow |F_{\text{contact}}| = Mg$$

4. A block 'A' takes 2 s to slide down a frictionless incline of  $30^\circ$  and length ' $l$ ', kept inside a lift going up with uniform velocity ' $v$ '. If the incline is changed to  $45^\circ$ , the time taken by the block, to slide down the incline, will be approximately

- (A) 2.66 s      (B) 0.83 s  
(C) 1.68 s      (D) 0.70 s

**Answer (C)**

Sol.  $\theta_1 = 30^\circ, \theta_2 = 45^\circ$

$$a_1 = g \sin \theta_1 = 5 \text{ m/s}^2, a_2 = g \sin \theta_2 = 5\sqrt{2} \text{ m/s}^2$$

$$\frac{t_1}{t_2} = \frac{\sqrt{\frac{2l}{a_1}}}{\sqrt{\frac{2l}{a_2}}} = \sqrt{\frac{a_2}{a_1}}$$

$$\frac{t_1}{t_2} = (2)^{1/4}$$

$$t_2 = (2)^{3/4} \approx 1.68 \text{ s}$$

5. The velocity of the bullet becomes one third after it penetrates 4 cm in a wooden block. Assuming that bullet is facing a constant resistance during its motion in the block. The bullet stops completely after travelling at  $(4 + x)$  cm inside the block. The value of  $x$  is

- (A) 2.0 (B) 1.0  
(C) 0.5 (D) 1.5

**Answer (C)**

Sol.  $S = 4 \text{ cm}$

$$v'_4 = \frac{v}{3}, a = \text{constant}$$

$$v_{4+x} = 0$$

$$\left( v^2 - \frac{v^2}{9} \right) = 2a(4)$$

$$(v^2 - 0) = 2a(4 + x)$$

$$\frac{4}{4+x} = \frac{8}{9}$$

$$\Rightarrow x = 0.5 \text{ m}$$

6. A body of mass  $m$  is projected with velocity  $\lambda v_e$  in vertically upward direction from the surface of the earth into space. It is given that  $v_e$  is escape velocity and  $\lambda < 1$ . If air resistance is considered to be negligible, then the maximum height from the centre of earth, to which the body can go, will be:

( $R$  : radius of earth)

(A)  $\frac{R}{1+\lambda^2}$

(B)  $\frac{R}{1-\lambda^2}$

(C)  $\frac{R}{1-\lambda}$

(D)  $\frac{\lambda^2 R}{1-\lambda^2}$

**Answer (B)**

Sol. Using energy conservation

$$-\frac{GM_e m}{R_e} + \frac{1}{2} m \left( \lambda \sqrt{\frac{2GM_e}{R_e}} \right)^2 = -\frac{GM_e m}{r}$$

$$\frac{GM_e m}{r} = \frac{GM_e m}{R_e} - \frac{GM_e m}{R_e} \lambda^2$$

$$r = \frac{R_e}{1-\lambda^2}$$

7. A steel wire of length 3.2 m ( $Y_s = 2.0 \times 10^{11} \text{ Nm}^{-2}$ ) and a copper wire of length 4.4 m ( $Y_c = 1.1 \times 10^{11} \text{ Nm}^{-2}$ ), both of radius 1.4 mm are connected end to end. When stretched by a load, the net elongation is found to be 1.4 mm. The load applied, in Newton,

will be: (Given  $\pi = \frac{22}{7}$ )

- (A) 360  
(B) 180  
(C) 1080  
(D) 154

**Answer (D)**

Sol.  $\Delta l_s + \Delta l_c = 1.4$

$$\frac{W l_s}{Y_s A} + \frac{W l_c}{Y_c \times A} = 1.4 \times 10^{-3}$$

$$W = \frac{1.4 \times 10^{-3}}{\left[ \frac{3.2}{2 \times (\pi \times 1.4 \times 10^{-3})^2} + \frac{4.4}{1.1 \times (\pi \times 1.4 \times 10^{-3})^2} \right]} \frac{1}{10^{+11}}$$

$$W \approx 154 \text{ N}$$

8. In 1<sup>st</sup> case, Carnot engine operates between temperatures 300 K and 100 K. In 2<sup>nd</sup> case, as shown in the figure, a combination of two engines is used. The efficiency of this combination (in 2<sup>nd</sup> case) will be:

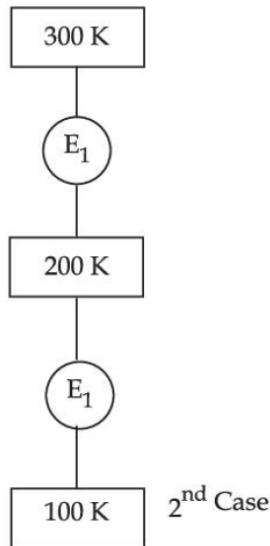

- (A) Same as the 1<sup>st</sup> case  
 (B) Always greater than the 1<sup>st</sup> case  
 (C) Always less than the 1<sup>st</sup> case  
 (D) May increase or decrease with respect to the 1<sup>st</sup> case

**Answer (C)**

**Sol.**  $\eta_{\text{net}} = \frac{W_1 + W_2}{Q_1}$

$$\eta_{\text{net}} = \frac{W_1}{Q_1} + \frac{W_2}{Q_1}$$

$$\eta_{\text{net}} = \eta_1 + \frac{W_2}{Q_2} \times \frac{Q_2}{Q_1}$$

$$\eta_{\text{net}} = \eta_1 + (\eta_2)(1 - \eta_1)$$

$$1 - \eta_1 < 1$$

$$\Rightarrow \eta_{\text{net}} < \eta_1 + \eta_2$$

9. Which statements are correct about degrees of freedom?
- (A) A molecule with  $n$  degrees of freedom has  $n^2$  different ways of storing energy.  
 (B) Each degree of freedom is associated with  $\frac{1}{2}RT$  average energy per mole.

- (C) A monatomic gas molecule has 1 rotational degree of freedom whereas diatomic molecule has 2 rotational degrees of freedom.  
 (D) CH<sub>4</sub> has a total of 6 degrees of freedom.

Choose the correct answer from the option given below:

- (A) (B) and (C) only      (B) (B) and (D) only  
 (C) (A) and (B) only      (D) (C) and (D) only

**Answer (B)**

**Sol.** Statement A is incorrect, statement B is correct by equipartition of energy. Statement C is incorrect as monoatomic does not have any rotational degree of freedom and CH<sub>4</sub> is a polyatomic gas so it has 6 degree of freedom. So only B and D are correct.

10. A charge of 4  $\mu\text{C}$  is to be divided into two. The distance between the two divided charges is constant. The magnitude of the divided charges so that the force between them is maximum, will be:

- (A) 1  $\mu\text{C}$  and 3  $\mu\text{C}$       (B) 2  $\mu\text{C}$  and 2  $\mu\text{C}$   
 (C) 0 and 4  $\mu\text{C}$       (D) 1.5  $\mu\text{C}$  and 2.5  $\mu\text{C}$

**Answer (B)**



**Sol.**  $q$        $4 - q$

$$\text{so } F = \frac{kq(4-q) \times 10^{-12}}{r^2}$$

so  $F_{\text{max}}$  will be at  $q = 2 \mu\text{C}$

11. (A) The drift velocity of electrons decreases with the increase in the temperature of conductor.  
 (B) The drift velocity is inversely proportional to the area of cross-section of given conductor.  
 (C) The drift velocity does not depend on the applied potential difference to the conductor.  
 (D) The drift velocity of electron is inversely proportional to the length of the conductor.  
 (E) The drift velocity increases with the increase in the temperature of conductor.

Choose the correct answer from the options given below

- (A) (A) and (B) only      (B) (A) and (D) only  
 (C) (B) and (E) only      (D) (B) and (C) only

**Answer (A)**

**Sol.**  $V_d$  decreases with increase in temperature and  $V_d$  is inversely proportional to the area of cross section.

12. A compass needle of oscillation magnetometer oscillates 20 times per minute at a place  $P$  of dip  $30^\circ$ . The number of oscillations per minute become 10 at another place  $Q$  of  $60^\circ$  dip. The ratio of the total magnetic field at the two places ( $B_Q : B_P$ ) is

- (A)  $\sqrt{3} : 4$  (B)  $4 : \sqrt{3}$   
 (C)  $\sqrt{3} : 2$  (D)  $2 : \sqrt{3}$

**Answer (A)**

**Sol.**  $T \propto \frac{1}{\sqrt{B \cos \delta}}$

$$\Rightarrow \frac{T_1}{T_2} = \sqrt{\frac{B_2 \cos \delta_2}{B_1 \cos \delta_1}}$$

$$\Rightarrow \frac{3 \text{ s}}{6 \text{ s}} = \sqrt{\frac{B_2}{B_1} \times \frac{\frac{1}{2}}{\frac{\sqrt{3}}{2}}}$$

$$\Rightarrow \frac{B_2}{B_1} = \left(\frac{1}{2}\right)^2 \times \sqrt{3} = \frac{\sqrt{3}}{4}$$

13. A cyclotron is used to accelerate protons. If the operating magnetic field is 1.0 T and the radius of the cyclotron 'dees' is 60 cm, the kinetic energy of the accelerated protons in MeV will be

[Use  $m_p = 1.6 \times 10^{-27}$  kg,  $e = 1.6 \times 10^{-19}$  C]

- (A) 12 (B) 18  
 (C) 16 (D) 32

**Answer (B)**

**Sol.**  $R = \frac{mv}{Bq} = \frac{\sqrt{2mK}}{Bq}$

$$\Rightarrow K = \frac{B^2 q^2 R^2}{2m}$$

$$= \frac{(1.6 \times 10^{-19})^2 \times 0.6^2}{2 \times 1.6 \times 10^{-27}} \text{ J}$$

$$= 18 \text{ MeV}$$

14. A series LCR circuit has  $L = 0.01$  H,  $R = 10 \Omega$  and  $C = 1 \mu\text{F}$  and it is connected to ac voltage of amplitude ( $V_m$ ) 50 V. At frequency 60% lower than resonant frequency, the amplitude of current will be approximately

- (A) 466 mA (B) 312 mA  
 (C) 238 mA (D) 196 mA

**Answer (C)**

**Sol.**  $\omega = 0.4\omega_0$  ... (i)

$$\Rightarrow I = \frac{V}{Z} = \frac{50}{\sqrt{R^2 + \left(\omega L - \frac{1}{\omega C}\right)^2}} \dots (ii)$$

$$\Rightarrow I = 238 \text{ mA}$$

15. Identify the correct statements from the following descriptions of various properties of electromagnetic waves.

- (A) In a plane electromagnetic wave electric field and magnetic field must be perpendicular to each other and direction of propagation of wave should be along electric field or magnetic field.  
 (B) The energy in electromagnetic wave is divided equally between electric and magnetic fields.  
 (C) Both electric field and magnetic field are parallel to each other and perpendicular to the direction of propagation of wave.  
 (D) The electric field, magnetic field and direction of propagation of wave must be perpendicular to each other.  
 (E) The ratio of amplitude of magnetic field to the amplitude of electric field is equal to speed of light.

Choose the **most appropriate** answer from the options given below

- (A) (D) only  
 (B) (B) and (D) only  
 (C) (B), (C) and (E) only  
 (D) (A), (B) and (E) only

**Answer (B)**

**Sol.** In an EM wave :

1.  $\vec{E} \perp \vec{B}$
2.  $\vec{V} \equiv \vec{E} \times \vec{B}$
3. Energy is equally divided
4.  $|\vec{V}| = |\vec{E}| / |\vec{B}|$

16. Two coherent sources of light interfere. The intensity ratio of two sources is 1 : 4. For this interference pattern if the value of  $\frac{I_{\max} + I_{\min}}{I_{\max} - I_{\min}}$  is

equal to  $\frac{2\alpha + 1}{\beta + 3}$ , then  $\frac{\alpha}{\beta}$  will be

- (A) 1.5                                      (B) 2  
(C) 0.5                                      (D) 1

**Answer (B)**

**Sol.**  $I_{\max} = (\sqrt{I_1} + \sqrt{I_2})^2$

$$I_{\min} = (\sqrt{I_1} - \sqrt{I_2})^2$$

$$\therefore \frac{I_{\max} + I_{\min}}{I_{\max} - I_{\min}} = \frac{2(I_1 + I_2)}{4 \times \sqrt{I_1 I_2}}$$

$$= \frac{1}{2} \times \frac{\left(\frac{I_1}{I_2} + 1\right)}{\sqrt{\frac{I_1}{I_2}}}$$

$$= \frac{1}{2} \times \frac{\left(\frac{1}{4} + 1\right)}{\left(\frac{1}{2}\right)}$$

$$= \frac{5}{4} = \frac{2 \times 2 + 1}{1 + 3}$$

$$\therefore \frac{\alpha}{\beta} = \frac{2}{1} = 2$$

17. With reference to the observations in photo-electric effect, identify the correct statements from below:

- (A) The square of maximum velocity of photoelectrons varies linearly with frequency of incident light.

- (B) The value of saturation current increases on moving the source of light away from the metal surface.  
(C) The maximum kinetic energy of photo-electrons decreases on decreasing the power of LED (Light emitting diode) source of light.  
(D) The immediate emission of photo-electrons out of metal surface can not be explained by particle nature of light/electromagnetic waves.  
(E) Existence of threshold wavelength can not be explained by wave nature of light/electromagnetic waves.

Choose the correct answer from the options given below.

- (A) (A) and (B) only  
(B) (A) and (E) only  
(C) (C) and (E) only  
(D) (D) and (E) only

**Answer (B)**

**Sol.**  $\therefore \frac{1}{2} m v_m^2 = h\nu - \phi$

$\Rightarrow v_m^2$  varies linearly with frequency.

And, threshold wavelength can be explained by particle nature of light.

18. The activity of a radioactive material is  $6.4 \times 10^{-4}$  curie. Its half life is 5 days. The activity will become  $5 \times 10^{-6}$  curie after

- (A) 7 days                                      (B) 15 days  
(C) 25 days                                      (D) 35 days

**Answer (D)**

**Sol.**  $\therefore A = \frac{A_0}{2^{t/T_{1/2}}}$

$$\Rightarrow 2^{t/5} = \frac{6.4 \times 10^{-4}}{5 \times 10^{-6}} = 128 = 2^7$$

$$\Rightarrow \frac{t}{5} = 7$$

$$\Rightarrow t = 35 \text{ days}$$

19. For a constant collector-emitter voltage of 8 V, the collector current of a transistor reached to the value of 6 mA from 4 mA, whereas base current changed from 20  $\mu$ A to 25  $\mu$ A value. If transistor is in active state, small signal current gain (current amplification factor) will be

- (A) 240
- (B) 400
- (C) 0.0025
- (D) 200

**Answer (B)**

**Sol.**  $\beta = \frac{\Delta I_C}{\Delta I_B}$

$$= \frac{(6 - 4) \times 10^{-3}}{(25 - 20) \times 10^{-6}}$$

$$= \frac{2}{5} \times 10^3$$

$$= 400$$

20. A square wave of the modulating signal is shown in the figure. The carrier wave is given by  $C(t) = 5 \sin(8\pi t)$  Volt. The modulation index is

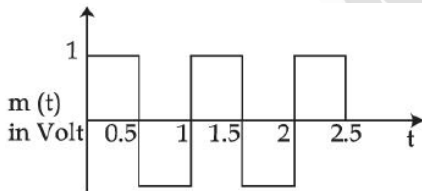

- (A) 0.2
- (B) 0.1
- (C) 0.3
- (D) 0.4

**Answer (A)**

**Sol.**  $\mu = \frac{A_m}{A_c}$

$$= \frac{1}{5}$$

$$= 0.2$$

**SECTION - B**

**Numerical Value Type Questions:** This section contains 10 questions. In Section B, attempt any five questions out of 10. The answer to each question is a **NUMERICAL VALUE**. For each question, enter the correct numerical value (in decimal notation, truncated/rounded-off to the second decimal place; e.g. 06.25, 07.00, -00.33, -00.30, 30.27, -27.30) using the mouse and the on-screen virtual numeric keypad in the place designated to enter the answer.

1. In an experiment to determine the Young's modulus, steel wires of five different lengths (1, 2, 3, 4 and 5 m) but of same cross section (2 mm<sup>2</sup>) were taken and curves between extension and load were obtained. The slope (extension/load) of the curves were plotted with the wire length and the following graph is obtained. If the Young's modulus of given steel wires is  $x \times 10^{11}$  Nm<sup>-2</sup>, then the value of x is \_\_\_\_\_.

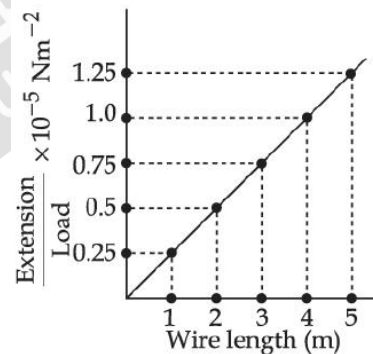

**Answer (2)**

**Sol.**  $Y = \frac{F \times l}{A \times \Delta l}$

$$= \frac{1}{A} \times \frac{\text{Wire length}}{\frac{\text{Extension}}{\text{load}}}$$

$$Y = \frac{1}{A} \times \left( \frac{1}{0.25 \times 10^{-5}} \right)$$

$$Y = 10^{11} \times 2$$

$$\Rightarrow x = 2$$



2. In the given figure of meter of bridge experiment, the balancing length AC corresponding to null deflection of the galvanometer is 40 cm. The balancing length, if the radius of the wire AB is doubled, will be \_\_\_\_\_ cm.

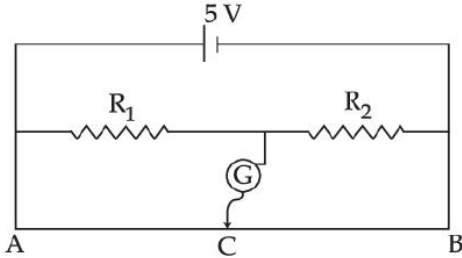

**Answer (40)**

**Sol.** Even if the radius of wire is doubled, the balancing point would not change as  $\frac{x}{l-x} = \frac{R_1}{R_2}$ , which is not including a term of area.

3. A thin prism of angle  $6^\circ$  and refractive index for yellow light ( $n_Y$ ) 1.5 is combined with another prism of angle  $5^\circ$  and  $n_Y = 1.55$ . The combination produces no dispersion. The net average deviation ( $\delta$ ) produced by the combination is  $\left(\frac{1}{x}\right)^\circ$ . The value of  $x$  is \_\_\_\_\_.

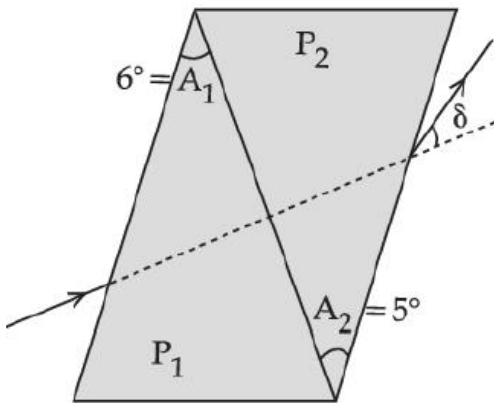

**Answer (4)**

**Sol.**  $\delta_{\text{net}} = \delta_1 + \delta_2$   
 $= |(\mu_1 - 1)A_1 - (\mu_2 - 1)A_2|$   
 $= |3^\circ - 2.75^\circ|$   
 $\delta_{\text{net}} = \frac{1^\circ}{4}$   
 $\Rightarrow x = 4$

4. A conducting circular loop is placed in X-Y plane in presence of magnetic field  $\vec{B} = (3t^3 \hat{j} + 3t^2 \hat{k})$  in SI unit. If the radius of the loop is 1 m, the induced emf in the loop, at time  $t = 2$  s is  $n\pi$  V. The value of  $n$  is \_\_\_\_\_.

**Answer (12)**

**Sol.**  $B_{\perp} = 3t^2$

$$\frac{dB_{\perp}}{dt} = 6t = 12 \text{ at } t = 2$$

$$\frac{d\phi_1}{dt} = 12 \times \pi(1)^2 = 12\pi$$

5. As show in the figure, in the steady state, the charge stored in the capacitor is \_\_\_\_\_  $\times 10^{-6}$  C,

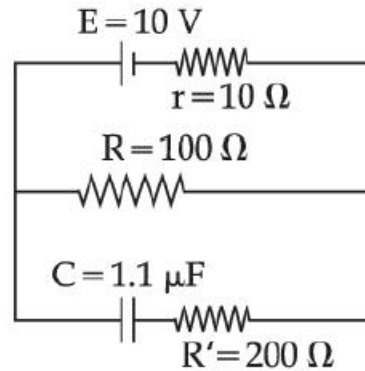

**Answer (10)**

**Sol.** At steady state potential difference across capacitor

$$V_c = \frac{10 \times 100}{110} \text{ V}$$

$$Q = CV_c$$

$$= \frac{1.1 \times 10^{-6} \times 10 \times 100}{110} \text{ C} = 10 \mu\text{C}$$

6. A parallel plate capacitor with width 4 cm, length 8 cm and separation between the plates of 4 mm is connected to a battery of 20 V. A dielectric slab of dielectric constant 5 having length 1 cm, width 4 cm and thickness 4 mm is inserted between the plates of parallel plate capacitor. The electrostatic energy of this system will be \_\_\_\_\_  $\epsilon_0$  J. (Where  $\epsilon_0$  is the permittivity of free space)

**Answer (240)**



Sol.  $d_1 = 4 \times 10^{-3}$

$A_1 = 8 \times 4 \times 10^{-4} \text{ m}^2$

$V = 20 \text{ V}$

$d_2 = 4 \times 10^{-3}$ ,

$A_2 = 4 \times 1 \times 10^{-4} \text{ m}^2$

$$C_{eq} = \frac{(A_1 + 5A_2 - A_2)\epsilon_0}{d} = \frac{3(16) \times 10^{-4}}{4 \times 10^{-3}} \epsilon_0$$

$$\epsilon = \frac{1}{2} C_{eq} V^2 = \frac{3}{2} \left( \frac{4}{10} \right) (400) \epsilon_0 = 240 \epsilon_0$$

7. A wire of length 30 cm, stretched between rigid supports, has its  $n^{\text{th}}$  and  $(n + 1)^{\text{th}}$  harmonics at 400 Hz and 450 Hz, respectively. If tension in the string is 2700 N, its linear mass density is \_\_\_\_\_ kg/m.

**Answer (3)**

Sol.  $\frac{v}{2l} = 50 \text{ Hz}$

$$\Rightarrow T = \left[ 100 \times \left( \frac{30}{100} \right) \right]^2 \times \mu$$

$$\Rightarrow \mu = \frac{2700}{900} = 3$$

8. A spherical soap bubble of radius 3 cm is formed inside another spherical soap bubble of radius 6 cm. If the internal pressure of the smaller bubble of radius 3 cm in the above system is equal to the internal pressure of the another single soap bubble of radius  $r$  cm. The value of  $r$  is \_\_\_\_\_

**Answer (2)**

Sol.  $\frac{4T}{R_1} + \frac{4T}{R_2} = \frac{4T}{r}$

$$\Rightarrow \frac{1}{r} = \frac{1}{3} + \frac{1}{6} \Rightarrow r = 2 \text{ cm}$$

9. A solid cylinder length is suspended symmetrically through two massless strings, as shown in the figure. The distance from the initial rest position, the cylinder should be unbinding the strings to achieve a speed of 4 m/s, is \_\_\_\_\_ cm. (Take  $g = 10 \text{ m/s}^2$ ).

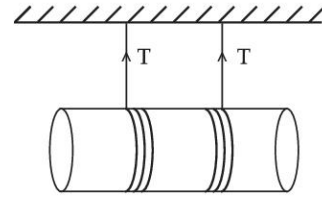

**Answer (120)**

Sol.  $\alpha = \frac{(mg)(r)}{\frac{3}{2}mr^2} = \frac{2g}{3r}$

$$\Rightarrow a = \frac{2g}{3}$$

$$\Rightarrow v^2 = 2as$$

$$16 = \frac{40}{3} \times s \Rightarrow s = 0.3 \times 4 = 120 \text{ cm}$$

10. Two inclined planes are placed as shown in figure. A block is projected from the point A of inclined plane AB along its surface with a velocity just sufficient to carry it to the top point B at a height 10 m. After reaching the point B the block sides down on inclined plane BC. Time it takes to reach to the point C from point A is  $t(\sqrt{2} + 1) \text{ s}$ . The value of  $t$  is \_\_\_\_\_. (Use  $g = 10 \text{ m/s}^2$ )

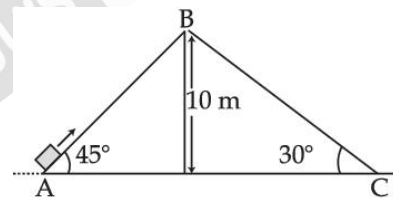

**Answer (2)**

Sol.  $AB = 10\sqrt{2} \text{ m}$

$$v_A = \sqrt{2 \times 10 \times 10} = 10\sqrt{2} \text{ m/s}$$

$$v_C = 10\sqrt{2} \text{ m/s}$$

$$a_{BC} = g \sin(30^\circ) = 5 \text{ m/s}^2$$

$$t_{BC} = 2\sqrt{2} \text{ s} \left( \frac{v_C}{a_{BC}} \right)$$

$$t_{AB} = \frac{v_A}{5\sqrt{2}} = 2 \text{ s}$$

$$t_{AB} + t_{BC} = 2(\sqrt{2} + 1)$$

$$\Rightarrow t = 2$$

## CHEMISTRY

### SECTION - A

**Multiple Choice Questions:** This section contains 20 multiple choice questions. Each question has 4 choices (1), (2), (3) and (4), out of which **ONLY ONE** is correct.

**Choose the correct answer :**

1. The correct decreasing order of energy for the orbitals having, following set of quantum numbers:

- (A)  $n = 3, l = 0, m = 0$     (B)  $n = 4, l = 0, m = 0$   
 (C)  $n = 3, l = 1, m = 0$     (D)  $n = 3, l = 2, m = 1$

- (A)  $(D) > (B) > (C) > (A)$   
 (B)  $(B) > (D) > (C) > (A)$   
 (C)  $(C) > (B) > (D) > (A)$   
 (D)  $(B) > (C) > (D) > (A)$

**Answer (A)**

**Sol.** Energy of an orbital is directly proportional to the  $(n + l)$  value

- |                    |  | $(n + l)$ |
|--------------------|--|-----------|
| (A) $n = 3, l = 0$ |  | 3         |
| (B) $n = 4, l = 0$ |  | 4         |
| (C) $n = 3, l = 1$ |  | 4         |
| (D) $n = 3, l = 2$ |  | 5         |

If  $n + l$  value is same then the orbital with lower value of 'n' will have lower energy.

$\therefore$  correct order of energy

$$D > B > C > A$$

2. Match List-I with List -II

- | List-I                            | List-II                              |
|-----------------------------------|--------------------------------------|
| (A) $\Psi_{MO} = \Psi_A - \Psi_B$ | (I) Dipole moment                    |
| (B) $\mu = Q \times r$            | (II) Bonding molecular orbital       |
| (C) $\frac{N_b - N_a}{2}$         | (III) Anti-bonding molecular orbital |
| (D) $\Psi_{MO} = \Psi_A + \Psi_B$ | (IV) Bond order                      |

Choose the correct answer from options given below:

- (A) (A)-(II), (B)-(I), (C)-(IV), (D)-(III)  
 (B) (A)-(III), (B)-(IV), (C)-(I), (D)-(II)  
 (C) (A)-(III), (B)-(I), (C)-(IV), (D)-(II)  
 (D) (A)-(III), (B)-(IV), (C)-(II), (D)-(I)

**Answer (C)**

**Sol.**  $\Psi_A - \Psi_B = \Psi_{MO}$  is anti-bonding molecular orbital

$\mu = Q \times r$  is dipole moment

$$\frac{N_b - N_a}{2} = \text{bond order}$$

$\Psi_A + \Psi_B = \Psi_{MO}$  is bonding molecular orbital.

3. The plot of pH-metric titration of weak base  $\text{NH}_4\text{OH}$  vs strong acid  $\text{HCl}$  looks like :

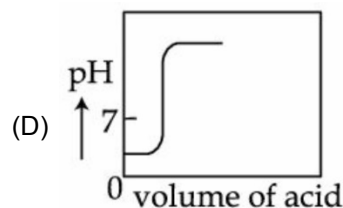
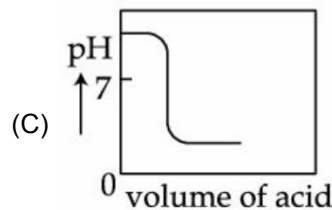
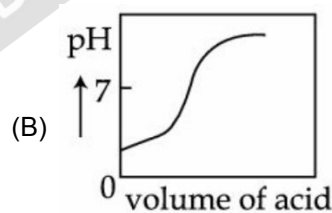
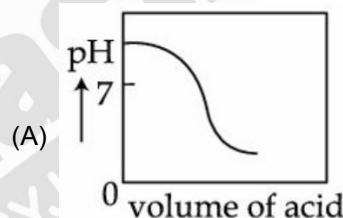

**Answer (A)**



**Sol** Lithium belongs to group-1, which has maximum hydration enthalpy among the group-1 elements.

Lithium shows diagonal relationship with Mg

8. Given below are two statements: one is labelled as **Assertion (A)** and the other is labelled as **Reason (R)**

**Assertion (A)** : Boron is unable to form  $\text{BF}_6^{3-}$

**Reason (R)** : Size of B is very small

In the light of the above statements, choose the correct answer from the options given below:

- (A) Both **(A)** and **(R)** are true and **(R)** is the correct explanation of **(A)**  
 (B) Both **(A)** and **(R)** are true but **(R)** is not the correct explanation of **(A)**  
 (C) **(A)** is true but **(R)** is false  
 (D) **(A)** is false but **(R)** is true

**Answer (B)**

**Sol** The outer most shell of Boron is 2 and its maximum covalency is 4.

Therefore, boron cannot form  $\text{BF}_6^{3-}$ .

Hence Assertion is correct

Boron is the first element of group-13 of modern periodic table. It is very small in size.

But it does not provide correct explanation of Assertion

9. In neutral or alkaline solution,  $\text{MnO}_4^-$  oxidises thiosulphate to :

- (A)  $\text{S}_2\text{O}_7^{2-}$                       (B)  $\text{S}_2\text{O}_8^{2-}$   
 (C)  $\text{SO}_3^{2-}$                         (D)  $\text{SO}_4^{2-}$

**Answer (D)**

**Sol**  $\text{H}_2\text{O} + 8\text{MnO}_4^- + 3\text{S}_2\text{O}_3^{2-} \rightarrow 8\text{MnO}_2 + 6\text{SO}_4^{2-} + 2\text{OH}^-$

10. Low oxidation state of metals in their complexes are common when ligands :

- (A) Have good  $\pi$ -accepting character  
 (B) Have good  $\sigma$ -donor character  
 (C) Are having good  $\pi$ -donating ability  
 (D) Are having poor  $\sigma$ -donating ability

**Answer (A)**

**Sol** Ligands like  $:\text{CO}$ , are sigma donor and  $\pi$ -acceptor and they make stronger bond with lower oxidation state metal ion, in this case back bonding is more effective

11. Given below are two statements:

**Statement I** : The non bio-degradable fly ash and slag from steel industry used by cement industry.

**Statement II** : The fuel obtained from plastic waste is lead free.

In the light of the above statements, choose the most appropriate answer from the options given below:

- (A) Both Statement I and Statement II are correct  
 (B) Both Statement I and Statement II are incorrect  
 (C) Statement I is correct but Statement II is incorrect  
 (D) Statement I is incorrect but Statement II is correct

**Answer (A)**

**Sol.** Both Statement are correct.

- Fuel obtained from plastic waste has high octane rating. It contain no lead and is known as "green fuel".
- The non bio-degradable fly ash and slag from steel industry can be used by cement industry.

12. The structure of A in the given reaction is:

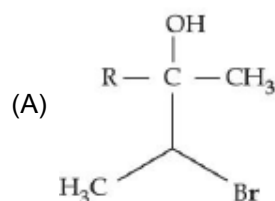
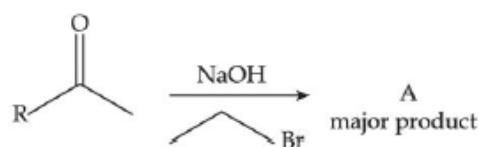

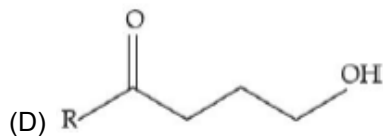
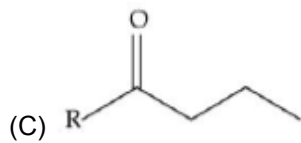
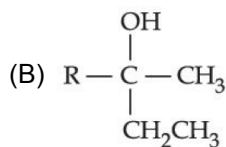

**Answer (C)**

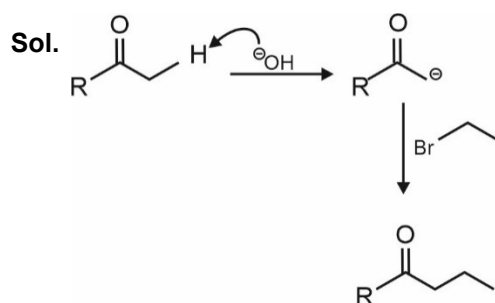

13. Major product 'B' of the following reaction sequence is:

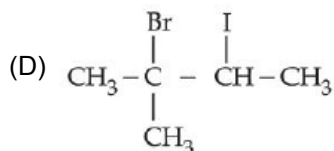
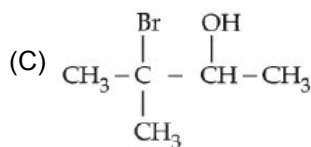
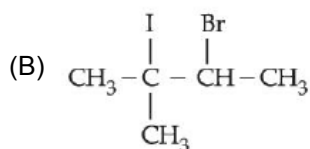
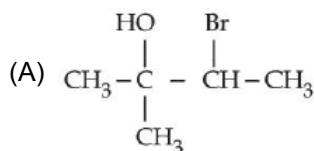
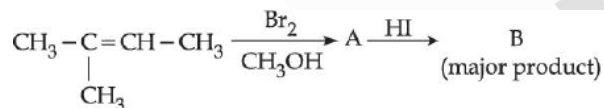

**Answer (B)**

**Sol.**

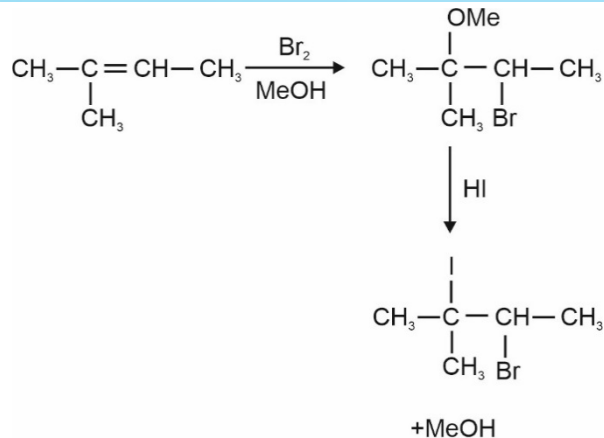

14. Match List-I with List-II

**List-I**

**List-II**

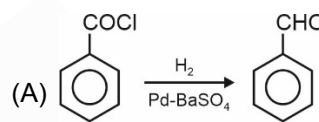

(I) Gatterman Koch reaction

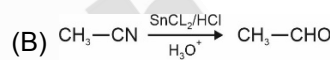

(II) Etard reaction

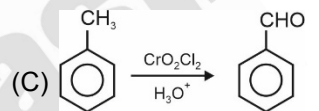

(III) Stephen reaction

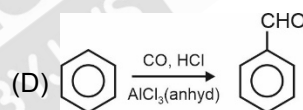

(IV) Rosenmund reaction

Choose the correct answer from the options given below:

(A) (A) - (IV), (B) - (III), (C) - (II), (D) - (I)

(B) (A) - (I), (B) - (II), (C) - (III), (D) - (IV)

(C) (A) - (II), (B) - (III), (C) - (IV), (D) - (I)

(D) (A) - (III), (B) - (II), (C) - (I), (D) - (IV)

**Answer (A)**

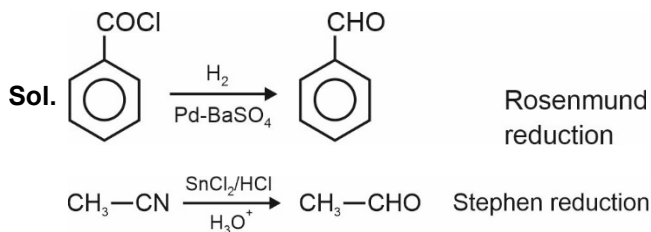

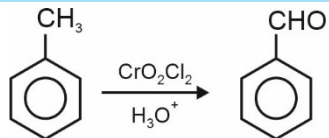

Etard reaction

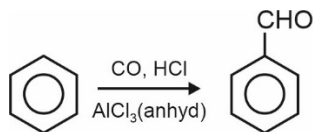

Gatterman-Koch reaction

15. Match List-I with List-II

**List-I**

**(Polymer)**

- (A) Neoprene
- (B) Teflon
- (C) Acrilan
- (D) Natural rubber

**List-II**

**(Monomer)**

- (I) Acrylonitrile
- (II) Chloroprene
- (III) Tetrafluoroethene
- (IV) Isoprene

Choose the correct answer from the options given below:

- (A) (A) - (II), (B) - (III), (C) - (I), (D) - (IV)
- (B) (A) - (II), (B) - (I), (C) - (III), (D) - (IV)
- (C) (A) - (II), (B) - (I), (C) - (IV), (D) - (III)
- (D) (A) - (I), (B) - (II), (C) - (III), (D) - (IV)

**Answer (A)**

**Sol. Polymer**

- Neoprene
- Teflon
- Acrilan (PAN)
- Natural rubber

**Monomer**

- Chloroprene
- $\text{CF}_2 = \text{CF}_2$
- Acrylonitrile
- Isoprene

16. An organic compound 'A' contains nitrogen and chlorine. It dissolves readily in water to give a solution that turns litmus red. Titration of compound 'A' with standard base indicates that the molecular weight of 'A' is  $131 \pm 2$ . When a sample of 'A' is treated with aq. NaOH, a liquid separates which contains N but not Cl. Treatment of the obtained liquid with nitrous acid followed by phenol gives orange precipitate. The compound A is :

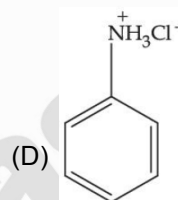
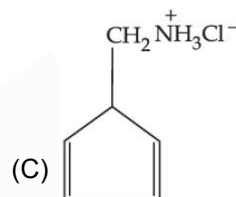
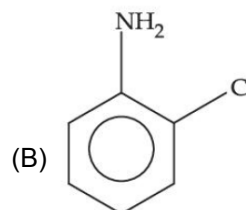
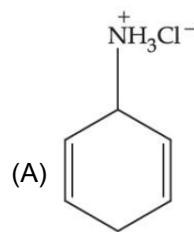

**Answer (D)**

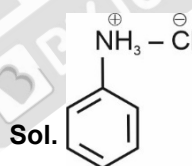

is acidic in nature as it can undergo cationic (A) hydrolysis in aqueous solution.

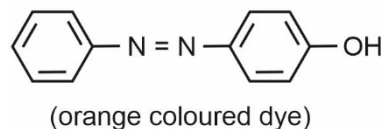
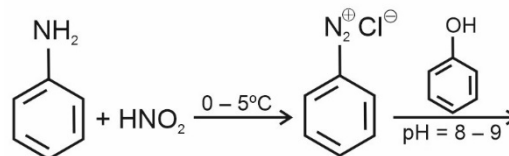
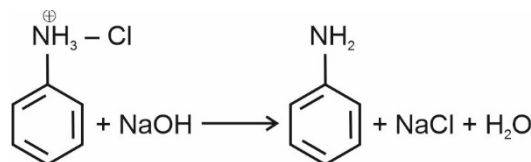



17. Match List-I with List-II

List-I	List-II
(A) Glucose + HI	(I) Gluconic acid
(B) Glucose + Br <sub>2</sub> water	(II) Glucose pentacetate
(C) Glucose + acetic anhydride	(III) Saccharic acid
(D) Glucose + HNO <sub>3</sub>	(IV) Hexane

Choose the correct answer from the options given below:

- (A) (A)-(IV), (B)-(I), (C)-(II), (D)-(III)  
 (B) (A)-(IV), (B)-(III), (C)-(II), (D)-(I)  
 (C) (A)-(III), (B)-(I), (C)-(IV), (D)-(II)  
 (D) (A)-(I), (B)-(III), (C)-(IV), (D)-(II)

**Answer (A)**

**Sol.** The correct match is:

- (A) Glucose+HI/Red P→(IV) Hexane  
 (B) Glucose+Br<sub>2</sub>/water→(I) Gluconic acid  
 (C) Glucose + acetic →(II) Glucose pentacetate Anhydride  
 (D) Glucose + HNO<sub>3</sub> →(III) Saccharic acid

All the above reactions establish open chain structure of glucose.

18. Which of the following enhances the lathering property of soap?

- (A) Sodium stearate      (B) Sodium carbonate  
 (C) Sodium rosinate      (D) Trisodium phosphate

**Answer (C)**

**Sol.** A gum called rosin is added to soap which forms sodium rosinate. It helps to produce lather.

19. Match List-I with List-II

List-I (Mixture)	List-II (Purification Process)
(A) Chloroform & Aniline	(I) Steam distillation
(B) Benzoic acid & Napthalene	(II) Sublimation
(C) Water & Aniline	(III) Distillation
(D) Napthalene & Sodium chloride	(IV) Crystallisation

Choose the correct answer from the options given below:

- (A) (A)-(IV), (B)-(III), (C)-(I), (D)-(II)  
 (B) (A)-(III), (B)-(I), (C)-(IV), (D)-(II)  
 (C) (A)-(III), (B)-(IV), (C)-(II), (D)-(I)  
 (D) (A)-(III), (B)-(IV), (C)-(I), (D)-(II)

**Answer (D)**

**Sol.** The correct match is

- (A) Chloroform & Aniline      (III) Simple distillation  
 (B) Benzoic acid & Napthalene      (IV) Crystallisation (Sublimation is not used as both sublime heating)  
 (C) Water & Aniline      (I) Steam distillation  
 (D) Napthalene & Sodium chloride      (II) Sublimation (only naphthalene has the tendency for sublimation)

20. Fe<sup>3+</sup> cation gives a Prussian blue precipitate on addition of potassium ferrocyanide solution due to the formation of:

- (A) [Fe(H<sub>2</sub>O)<sub>6</sub>]<sub>2</sub> [Fe(CN)<sub>6</sub>]  
 (B) Fe<sub>2</sub>[Fe(CN)<sub>6</sub>]<sub>2</sub>  
 (C) Fe<sub>3</sub>[Fe(OH)<sub>2</sub> (CN)<sub>4</sub>]<sub>2</sub>  
 (D) Fe<sub>4</sub>[Fe(CN)<sub>6</sub>]<sub>3</sub>

**Answer (D)**

**Sol.** Fe<sup>+3</sup> + K<sub>4</sub>[Fe(CN)<sub>6</sub>] → Fe<sub>4</sub>[Fe(CN)<sub>6</sub>]<sub>3</sub>

Prussian blue ppt

**SECTION - B**

**Numerical Value Type Questions:** This section contains 10 questions. In Section B, attempt any five questions out of 10. The answer to each question is a **NUMERICAL VALUE**. For each question, enter the correct numerical value (in decimal notation, truncated/rounded-off to the second decimal place; e.g. 06.25, 07.00, -00.33, -00.30, 30.27, -27.30) using the mouse and the on-screen virtual numeric keypad in the place designated to enter the answer.



1. The normality of  $\text{H}_2\text{SO}_4$  in the solution obtained on mixing 100 mL of 0.1 M  $\text{H}_2\text{SO}_4$  with 50 mL of 0.1 M  $\text{NaOH}$  is \_\_\_\_\_  $\times 10^{-1}$  N. (Nearest Integer)

**Answer (01.00)**

**Sol.**

	$\text{H}_2\text{SO}_4 + 2\text{NaOH} \longrightarrow \text{Na}_2\text{SO}_4 + \text{H}_2\text{O}$			
Initial millimoles	10	5	-	-
Final millimoles	7.5	-	2.5	-

$$\text{Molarity of } \text{H}_2\text{SO}_4 = \frac{7.5}{150} = \frac{1}{20} \text{ M}$$

$$\begin{aligned} \text{Normality of } \text{H}_2\text{SO}_4 &= \frac{1}{20} \times 2 = 0.1 \text{ N} \\ &= 1 \times 10^{-1} \text{ N} \end{aligned}$$

2. For a real gas at  $25^\circ\text{C}$  temperature and high pressure (99 bar) the value of compressibility factor is 2, so the value of Van der Waal's constant 'b' should be \_\_\_\_\_  $\times 10^{-2}$  L  $\text{mol}^{-1}$  (Nearest integer)

(Given  $R = 0.083$  L bar  $\text{K}^{-1}$   $\text{mol}^{-1}$ )

**Answer (25.00)**

**Sol.** For 1 mole at high pressure

$$P(V - b) = RT$$

$$PV - Pb = RT$$

$$\frac{PV}{RT} = 1 + \frac{Pb}{RT}$$

$$Z = 1 + \frac{Pb}{RT}$$

$$1 = \frac{99(b)}{0.083 \times 298}$$

$$b = \frac{0.083 \times 298}{99} \approx 0.249 \approx 25 \times 10^{-2}$$

3. A gas (Molar mass =  $280 \text{ g mol}^{-1}$ ) was burnt in excess  $\text{O}_2$  in a constant volume calorimeter and during combustion the temperature of calorimeter increased from  $298.0 \text{ K}$  to  $298.45 \text{ K}$ . If the heat capacity of calorimeter is  $2.5 \text{ kJ K}^{-1}$  and enthalpy of combustion of gas is  $9 \text{ kJ mol}^{-1}$  then amount of gas burnt is \_\_\_\_\_ g. (Nearest Integer)

**Answer (35.00)**

**Sol.**  $\Delta U = C \Delta T$

$$= 2.5 \times 10^3 \times 0.45$$

$$= 1.125 \text{ kJ}$$

Considering  $\Delta H \approx \Delta U$

$$\Delta H = 9 \text{ kJ/mol} \approx \Delta U$$

$$\therefore \text{Mass of gas burnt} = \frac{1.125}{9} \times 280 = 35 \text{ g}$$

4. When a certain amount of solid A is dissolved in 100 g of water at  $25^\circ\text{C}$  to make a dilute solution, the vapour pressure of the solution is reduced to one-half of that of pure water. The vapour pressure of pure water is  $23.76 \text{ mmHg}$ . The number of moles of solute A added is \_\_\_\_\_. (Nearest Integer)

**Answer (06.00)**

**Sol.**  $\frac{P_o - P_s}{P_s} = \frac{n_A}{n_B}$

$$1 = \frac{n_A}{n_B}$$

$$n_A = n_B$$

$\therefore$  Moles of solute added considering it as a non-electrolyte

$$= \frac{100}{18} \approx 5.55$$

$$\approx 6$$

5.  $[\text{A}] \rightarrow [\text{B}]$   
 Reactant                      Product

If formation of compound [B] follows the first order of kinetics and after 70 minutes the concentration of [A] was found to be half of its initial concentration. Then the rate constant of the reaction is  $x \times 10^{-6} \text{ s}^{-1}$ . The value of x is \_\_\_\_\_. (Nearest Integer)

**Answer (165)**

**Sol.** A  $\longrightarrow$  B

Reactant                      Product

$$k = \frac{0.693}{70 \times 60} = 165 \times 10^{-6} \text{ s}^{-1}$$

$$\therefore x = 165$$

6. Among the following ores Bauxite, Siderite, Cuprite, Calamine, Haematite, Kaolinite, Malachite, Magnetite, Sphalerite, Limonite, Cryolite, the number of principal ores of iron is \_\_\_\_.

**Answer (04.00)**

**Sol.** The principal ores of iron are :

Siderite, Haematite, Magnetite, Limonite.

7. The oxidation state of manganese in the product obtained in a reaction of potassium permanganate and hydrogen peroxide in basic medium is \_\_\_\_.

**Answer (04.00)**

**Sol.**  $2\text{MnO}_4^- + 3\text{H}_2\text{O}_2 \rightarrow 2\text{MnO}_2 + 3\text{O}_2 + 2\text{H}_2\text{O} + 2\text{OH}^-$

Oxidation state of Mn in  $\text{MnO}_2 = +4$

8. The number of molecules(s) or ions(s) from the following having non-planar structure is \_\_\_\_.

$\text{NO}_3^-$ ,  $\text{H}_2\text{O}_2$ ,  $\text{BF}_3$ ,  $\text{PCl}_3$ ,  $\text{XeF}_4$ ,  $\text{SF}_4$ ,  $\text{SF}_4$ ,

$\text{XeO}_3$ ,  $\text{PH}_4^+$ ,  $\text{SO}_3$ ,  $[\text{Al}(\text{OH})_4]^-$

**Answer (06.00)**

**Sol.**  $\text{NO}_3^- \rightarrow$  Trigonal planar (Planar)

$\text{H}_2\text{O}_2 \rightarrow$  Open book (Non-planar)

$\text{BF}_3 \rightarrow$  Trigonal planar (Planar)

$\text{PCl}_3 \rightarrow$  Pyramidal (Non-planar)

$\text{XeF}_4 \rightarrow$  Square planar (Planar)

$\text{SF}_4 \rightarrow$  See-Saw (Non-planar)

$\text{XeO}_3 \rightarrow$  Pyramidal (Non-planar)

$\text{PH}_4^+ \rightarrow$  Tetrahedral (Non-planar)

$\text{SO}_3 \rightarrow$  Trigonal planar (Planar)

$[\text{Al}(\text{OH})_4]^- \rightarrow$  Tetrahedral (Non-planar)

9. The spin only magnetic moment of the complex present in Fehling's reagent is \_\_\_\_ B.M. (Nearest integer).

**Answer (02.00)**

**Sol.** In the complex present in Fehling's reagent,  $\text{Cu}^{+2}$  ion is present.

So, spin only magnetic moment

$$= \sqrt{1(1+2)}$$

$$= \sqrt{3} \approx 2 \text{ B.M.}$$

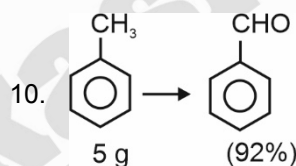

In the above reaction, 5 g of toluene is converted into benzaldehyde with 92% yield. The amount of benzaldehyde produced is \_\_\_\_  $\times 10^{-2}$  g. (Nearest integer).

**Answer (530)**

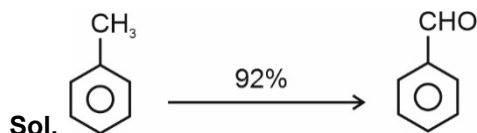

$$\text{Moles} = \frac{5}{92}$$

$$\text{Moles of benzaldehyde produced} = \frac{5}{92} \times 0.92 = 0.05$$

$\therefore$  Mass of benzaldehyde formed

$$= 0.05 \times 106$$

$$= 5.3 \text{ g}$$

$$= 530 \times 10^{-2}$$

**MATHEMATICS**

**SECTION - A**

**Multiple Choice Questions:** This section contains 20 multiple choice questions. Each question has 4 choices (1), (2), (3) and (4), out of which **ONLY ONE** is correct.

**Choose the correct answer :**

1. The domain of the function

$$f(x) = \sin^{-1}[2x^2 - 3] + \log_2 \left( \log_1 \left( x^2 - 5x + 5 \right) \right),$$

where  $[t]$  is the greatest integer function, is

- (A)  $\left(-\sqrt{\frac{5}{2}}, \frac{5-\sqrt{5}}{2}\right)$       (B)  $\left(\frac{5-\sqrt{5}}{2}, \frac{5+\sqrt{5}}{2}\right)$   
 (C)  $\left(1, \frac{5-\sqrt{5}}{2}\right)$       (D)  $\left(1, \frac{5+\sqrt{5}}{2}\right)$

**Answer (C)**

**Sol.**  $-1 \leq 2x^2 - 3 < 2$        $\log_1(x^2 - 5x + 5) > 0$   
 or  $2 \leq 2x^2 < 5$        $0 < x^2 - 5x + 5 < 1$   
 or  $1 \leq x^2 < \frac{5}{2}$        $x^2 - 5x + 5 > 0$  &  $x^2 - 5x + 4 < 0$   
 $x \in \left(-\sqrt{\frac{5}{2}}, -1\right]$        $x \in \left(-\infty, \frac{5-\sqrt{5}}{2}\right) \cup \left(\frac{5+\sqrt{5}}{2}, \infty\right)$   
 $\cup \left[1, \sqrt{\frac{5}{2}}\right)$       &  $x \in (-\infty, 1) \cup (4, \infty)$

Taking intersection

$$x \in \left(1, \frac{5-\sqrt{5}}{2}\right)$$

2. Let S be the set of all  $(\alpha, \beta)$ ,  $\pi < \alpha, \beta < 2\pi$ , for which the complex number  $\frac{1-i\sin\alpha}{1+2i\sin\alpha}$  is purely imaginary

and  $\frac{1+i\cos\beta}{1-2i\cos\beta}$  is purely real, Let  $Z_{\alpha\beta} = \sin 2\alpha + i$

$\cos 2\beta$ ,  $(\alpha, \beta) \in S$ . Then  $\sum_{(\alpha,\beta) \in S} \left( iZ_{\alpha\beta} + \frac{1}{iZ_{\alpha\beta}} \right)$  is

equal to

- (A) 3      (B)  $3i$   
 (C) 1      (D)  $2-i$

**Answer (C)**

**Sol.**  $\therefore \frac{1-i\sin\alpha}{1+2i\sin\alpha}$  is purely imaginary

$$\therefore \frac{1-i\sin\alpha}{1+2i\sin\alpha} + \frac{1+i\sin\alpha}{1-2i\sin\alpha} = 0$$

$$\Rightarrow 1 - 2\sin^2\alpha = 0$$

$$\therefore \alpha = \frac{5\pi}{4}, \frac{7\pi}{4}$$

and  $\frac{1+i\cos\beta}{1-2i\cos\beta}$  is purely real

$$\frac{1+i\cos\beta}{1-2i\cos\beta} - \frac{1-i\cos\beta}{1+2i\cos\beta} = 0$$

$$\Rightarrow \cos\beta = 0$$

$$\therefore \beta = \frac{3\pi}{2}$$

$$\therefore S = \left\{ \left( \frac{5\pi}{4}, \frac{3\pi}{2} \right), \left( \frac{7\pi}{4}, \frac{3\pi}{2} \right) \right\}$$

$$Z_{\alpha\beta} = 1-i \text{ and } Z_{\alpha\beta} = -1-i$$

$$\therefore \sum_{(\alpha,\beta) \in S} \left( iZ_{\alpha\beta} + \frac{1}{iZ_{\alpha\beta}} \right) = i(-2i) + \frac{1}{i} \left[ \frac{1}{1+i} + \frac{1}{-1+i} \right]$$

$$= 2 + \frac{1 \cdot 2i}{i-2} = 1$$

3. If  $\alpha, \beta$  are the roots of the equation

$$x^2 - \left( 5 + 3\sqrt{\log_3 5} - 5\sqrt{\log_5 3} \right) + 3 \left( 3^{(\log_3 5)^{\frac{1}{3}}} - 5^{(\log_5 3)^{\frac{2}{3}}} - 1 \right) = 0,$$

then the equation, whose roots are  $\alpha + \frac{1}{\beta}$  and

$\beta + \frac{1}{\alpha}$ , is

- (A)  $3x^2 - 20x - 12 = 0$       (B)  $3x^2 - 10x - 4 = 0$   
 (C)  $3x^2 - 10x + 2 = 0$       (D)  $3x^2 - 20x + 16 = 0$

**Answer (B)**

**Sol.**  $3\sqrt{\log_3 5} - 5\sqrt{\log_5 3} = 3\sqrt{\log_3 5} - \left( 3^{\log_3 5} \right)^{\sqrt{\log_5 3}}$   
 $= 0$

$$3^{(\log_3 5)^{\frac{1}{3}}} - 5^{(\log_5 3)^{\frac{2}{3}}} = 5^{(\log_5 3)^{\frac{2}{3}}} - 5^{(\log_5 3)^{\frac{2}{3}}}$$

$$= 0$$

Note : IN the given equation 'x' is missing.

$$\text{So } x^2 - 5x + 3(-1) = 0 \begin{cases} \alpha \\ \beta \end{cases}$$

$$\alpha + \beta + \frac{1}{\alpha} + \frac{1}{\beta} = (\alpha + \beta) + \frac{\alpha + \beta}{\alpha\beta}$$

$$= 5 - \frac{5}{3} = \frac{10}{3}$$

$$\left(\alpha + \frac{1}{\beta}\right)\left(\beta + \frac{1}{\alpha}\right) = 2 + \alpha\beta + \frac{1}{\alpha\beta} = 2 - 3 - \frac{1}{3}$$

$$= -\frac{4}{3}$$

So Equation must be option (B)

4. Let  $A = \begin{pmatrix} 4 & -2 \\ \alpha & \beta \end{pmatrix}$

If  $A^2 + \gamma A + 18I = 0$ , then  $\det(A)$  is equal to \_\_\_\_\_.

- (A) -18                      (B) 18  
(C) -50                      (D) 50

**Answer (B)**

**Sol.** Characteristic equation of  $A$  is given by

$$|A - \lambda I| = 0$$

$$\begin{vmatrix} 4 - \lambda & -2 \\ \alpha & \beta - \lambda \end{vmatrix} = 0$$

$$\Rightarrow \lambda^2 - (4 + \beta)\lambda + (4\beta + 2\alpha) = 0$$

$$\text{So, } A^2 - (4 + \beta)A + (4\beta + 2\alpha)I = 0$$

$$|A| = 4\beta + 2\alpha = 18$$

5. If for  $p \neq q \neq 0$ , the function  $f(x) = \frac{\sqrt[7]{p(729+x)} - 3}{\sqrt[3]{729+qx} - 9}$

is continuous at  $x = 0$ , then

- (A)  $7pq f(0) - 1 = 0$               (B)  $63q f(0) - p^2 = 0$   
(C)  $21q f(0) - p^2 = 0$               (D)  $7pq f(0) - 9 = 0$

**Answer (B)**

**Sol.**  $f(x) = \frac{\sqrt[7]{p(729+x)} - 3}{\sqrt[3]{729+qx} - 9}$

for continuity at  $x = 0$ ,  $\lim_{x \rightarrow 0} f(x) = f(0)$

$$\text{Now, } \therefore \lim_{x \rightarrow 0} f(x) = \lim_{x \rightarrow 0} \frac{\sqrt[7]{p(729+x)} - 3}{\sqrt[3]{729+qx} - 9}$$

$\Rightarrow p = 3$  (To make indeterminate form)

$$\text{So, } \lim_{x \rightarrow 0} f(x) = \lim_{x \rightarrow 0} \frac{(3^7 + 3x)^{\frac{1}{7}} - 3}{(729 + qx)^{\frac{1}{3}} - 9}$$

$$= \lim_{x \rightarrow 0} \frac{3 \left[ \left(1 + \frac{x}{3^6}\right)^{\frac{1}{7}} - 1 \right]}{9 \left[ \left(1 + \frac{q}{729}x\right)^{\frac{1}{3}} - 1 \right]} = \frac{1}{3} \cdot \frac{1}{\frac{1}{7} \cdot \frac{1}{3^6}} \cdot \frac{1}{\frac{1}{3} \cdot \frac{1}{729}}$$

$$\therefore f(0) = \frac{1}{7q}$$

$\therefore$  Option (B) is correct

6. Let  $f(x) = 2 + |x| - |x-1| + |x+1|, x \in R$ . Consider

$$(S1): f'\left(-\frac{3}{2}\right) + f'\left(-\frac{1}{2}\right) + f'\left(\frac{1}{2}\right) + f'\left(\frac{3}{2}\right) = 2$$

$$(S2): \int_{-2}^2 f(x) dx = 12$$

Then,

- (A) Both (S1) and (S2) are correct  
(B) Both (S1) and (S2) are wrong  
(C) Only (S1) is correct  
(D) Only (S2) is correct

**Answer (D)**

**Sol.**  $f(x) = 2 + |x| - |x-1| + |x+1|, x \in R$

$$\therefore f(x) = \begin{cases} -x & , x < -1 \\ x+2 & , -1 \leq x < 0 \\ 3x+2 & , 0 \leq x < 1 \\ x+4 & , x \geq 1 \end{cases}$$

$$\therefore f'\left(-\frac{3}{2}\right) + f'\left(-\frac{1}{2}\right) + f'\left(\frac{1}{2}\right) + f'\left(\frac{3}{2}\right) = -1 + 1 + 3 + 1 = 4$$

$$\text{and } \int_{-2}^2 f(x) dx = \int_{-2}^{-1} f(x) dx + \int_{-1}^0 f(x) dx + \int_0^1 f(x) dx + \int_1^2 f(x) dx$$

$$= \left[-\frac{x^2}{2}\right]_{-2}^{-1} + \left[\frac{(x+2)^2}{2}\right]_{-1}^0 + \left[\frac{(3x+2)^2}{6}\right]_0^1 + \left[\frac{(x+4)^2}{2}\right]_1^2$$

$$= \frac{3}{2} + \frac{3}{2} + \frac{7}{2} + \frac{11}{2} = \frac{24}{2} = 12$$

$\therefore$  Only (S2) is correct

7. Let the sum of an infinite G.P., whose first term is  $a$  and the common ratio is  $r$ , be 5. Let the sum of its first five terms be  $\frac{98}{25}$ . Then the sum of the first 21 terms of an AP, whose first term is  $10ar$ ,  $n^{\text{th}}$  term is  $a_n$  and the common difference is  $10ar^2$ , is equal to
- (A)  $21 a_{11}$                       (B)  $22 a_{11}$   
(C)  $15 a_{16}$                       (D)  $14 a_{16}$

**Answer (A)**

**Sol.** Let first term of G.P. be  $a$  and common ratio is  $r$

Then,  $\frac{a}{1-r} = 5 \dots(i)$

$$a \frac{(r^5 - 1)}{(r - 1)} = \frac{98}{25} \Rightarrow 1 - r^5 = \frac{98}{125}$$

$$\therefore r^5 = \frac{27}{125}, r = \left(\frac{3}{5}\right)^{\frac{3}{5}}$$

$$\begin{aligned} \therefore \text{Then, } S_{21} &= \frac{21}{2} [2 \times 10ar + 20 \times 10ar^2] \\ &= 21 [10ar + 10 \cdot 10ar^2] \\ &= 21 a_{11} \end{aligned}$$

8. The area of the region enclosed by  $y \leq 4x^2$ ,  $x^2 \leq 9y$  and  $y \leq 4$ , is equal to
- (A)  $\frac{40}{3}$                       (B)  $\frac{56}{3}$   
(C)  $\frac{112}{3}$                       (D)  $\frac{80}{3}$

**Answer (D)**

**Sol.**

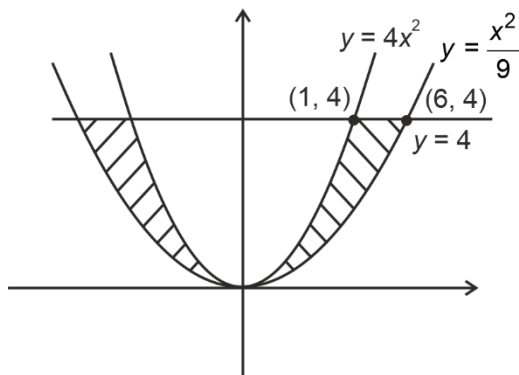

$$y \leq 4x^2, x^2 \leq 9y, y \leq 4$$

So, required area

$$\begin{aligned} A &= 2 \int_0^4 \left( 3\sqrt{y} - \frac{1}{2}\sqrt{y} \right) dy \\ &= 2 \cdot \frac{5}{2} \left[ \frac{2}{3} y^{\frac{3}{2}} \right]_0^4 \\ &= \frac{10}{3} \left[ 4^{\frac{3}{2}} - 0 \right] = \frac{80}{3} \end{aligned}$$

9.  $\int_0^2 \left( |2x^2 - 3x| + \left[ x - \frac{1}{2} \right] \right) dx$ , where  $[f]$  is the greatest integer function, is equal to
- (A)  $\frac{7}{6}$                       (B)  $\frac{19}{12}$   
(C)  $\frac{31}{12}$                       (D)  $\frac{3}{2}$

**Answer (B)**

**Sol.**  $\int_0^2 |2x^2 - 3x| dx + \int_0^2 \left[ x - \frac{1}{2} \right] dx$

$$\begin{aligned} &= \int_0^{\frac{3}{2}} (3x - 2x^2) dx + \int_{\frac{3}{2}}^2 (2x^2 - 3x) dx + \int_0^{\frac{1}{2}} -1 dx \\ &\quad + \int_{\frac{1}{2}}^{\frac{3}{2}} 0 dx + \int_{\frac{3}{2}}^2 1 dx \\ &= \left( \frac{3x^2}{2} - \frac{2x^3}{3} \right) \Big|_0^{\frac{3}{2}} + \left( \frac{2x^3}{3} - \frac{3x^2}{2} \right) \Big|_{\frac{3}{2}}^2 - \frac{1}{2} + \frac{1}{2} \\ &= \left( \frac{27}{8} - \frac{27}{12} \right) + \left( \frac{16}{3} - 6 - \frac{27}{12} + \frac{27}{8} \right) \\ &= \frac{19}{12} \end{aligned}$$

10. Consider a curve  $y = y(x)$  in the first quadrant as shown in the figure. Let the area  $A_1$  is twice the area  $A_2$ . Then the normal to the curve perpendicular to the line  $2x - 12y = 15$  does **NOT** pass through the point.

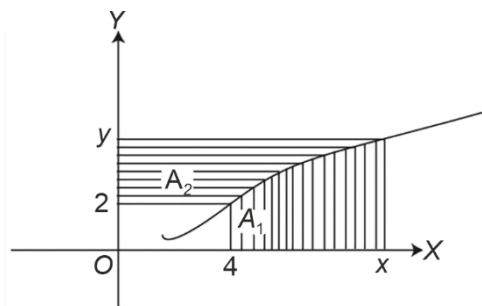

- (A) (6, 21)                      (B) (8, 9)  
(C) (10, -4)                      (D) (12, -15)

**Answer (C)**

Sol.

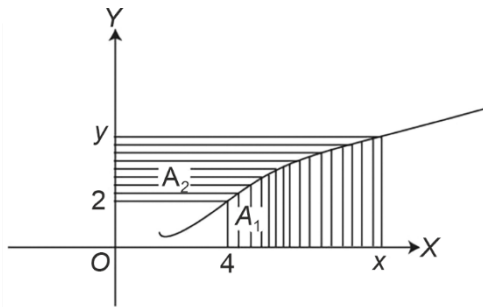

$$A_1 + A_2 = xy - 8 \text{ \& } A_1 = 2A_2$$

$$A_1 + \frac{A_1}{2} = xy - 8$$

$$A_1 = \frac{2}{3}(xy - 8)$$

$$\int_4^x f(x) dx = \frac{2}{3}(xf(x) - 8)$$

Differentiate w.r.t.  $x$

$$f(x) = \frac{2}{3}\{xf'(x) + f(x)\}$$

$$\frac{2}{3}xf'(x) = \frac{1}{3}f(x)$$

$$2 \int \frac{f'(x)}{f(x)} dx = \int \frac{dx}{x}$$

$$2 \ln f(x) = \ln x + \ln c$$

$$f^2(x) = cx$$

Which passes through  $(4, 2)$

$$4 = c \times 4 \Rightarrow c = 1$$

Equation of required curve

$$\boxed{y^2 = x}$$

Equation of normal having slope  $(-6)$  is

$$y = -6x - 2\left(\frac{1}{4}\right)(-6) - \frac{1}{4}(-6)^3$$

$$y = -6x + 57$$

Which does not pass through  $(10, -4)$

11. The equations of the sides  $AB$ ,  $BC$  and  $CA$  of a triangle  $ABC$  are  $2x + y = 0$ ,  $x + py = 39$  and  $x - y = 3$  respectively and  $P(2, 3)$  is its circumcentre. Then which of the following is **NOT** true?

- (A)  $(AC)^2 = 9p$
- (B)  $(AC)^2 + p^2 = 136$
- (C)  $32 < \text{area}(\Delta ABC) < 36$
- (D)  $34 < \text{area}(\Delta ABC) < 38$

**Answer (D)**

Sol. Intersection of  $2x + y = 0$  and  $x - y = 3 : A(1, -2)$

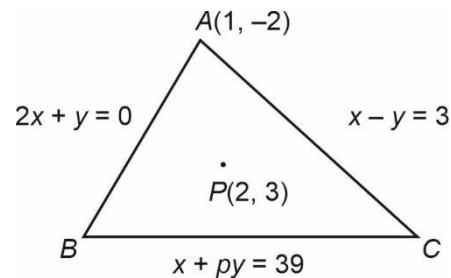

Equation of perpendicular bisector of  $AB$  is

$$x - 2y = -4$$

Equation of perpendicular bisector of  $AC$  is

$$x + y = 5$$

Point  $B$  is the image of  $A$  in line  $x - 2y + 4 = 0$

which can be obtained as  $B\left(\frac{-13}{5}, \frac{26}{5}\right)$

Similarly vertex  $C : (7, 4)$

Equation of line  $BC : x + 8y = 39$

So,  $p = 8$

$$AC = \sqrt{(7-1)^2 + (4+2)^2} = 6\sqrt{2}$$

Area of triangle  $ABC = 32.4$

12. A circle  $C_1$  passes through the origin  $O$  and has diameter 4 on the positive  $x$ -axis. The line  $y = 2x$  gives a chord  $OA$  of circle  $C_1$ . Let  $C_2$  be the circle with  $OA$  as a diameter. If the tangent to  $C_2$  at the point  $A$  meets the  $x$ -axis at  $P$  and  $y$ -axis at  $Q$ , then  $QA : AP$  is equal to
- (A) 1 : 4
  - (B) 1 : 5
  - (C) 2 : 5
  - (D) 1 : 3

**Answer (A)**

Sol. Equation of  $C_1$

$$x^2 + y^2 - 4x = 0$$

Intersection with

$$y = 2x$$

$$x^2 + 4x^2 - 4x = 0$$

$$5x^2 - 4x = 0 \Rightarrow x = 0, \frac{4}{5}$$

$$y = 0, \frac{8}{5}$$

$$A : \left(\frac{4}{5}, \frac{8}{5}\right)$$

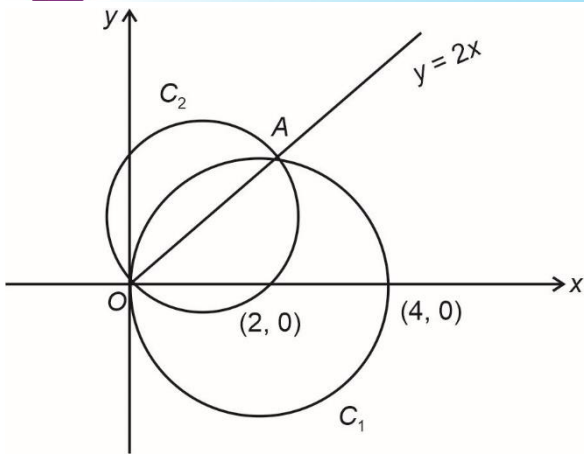

Tangent of  $C_2$  at  $A\left(\frac{4}{5}, \frac{8}{5}\right)$

$$x + 2y = 4 \Rightarrow P : (4, 0), Q : (0, 2)$$

$$QA : AP = 1 : 4$$

13. If the length of the latus rectum of a parabola, whose focus is  $(a, a)$  and the tangent at its vertex is  $x + y = a$ , is 16, then  $|a|$  is equal to :

- (A)  $2\sqrt{2}$                       (B)  $2\sqrt{3}$   
(C)  $4\sqrt{2}$                       (D) 4

**Answer (C)**

**Sol.** Equation of tangent at vertex :  $L \equiv x + y - a = 0$

Focus :  $F \equiv (a, a)$

Perpendicular distance of  $L$  from  $F$

$$= \left| \frac{a + a - a}{\sqrt{2}} \right| = \left| \frac{a}{\sqrt{2}} \right|$$

$$\text{Length of latus rectum} = 4 \left| \frac{a}{\sqrt{2}} \right|$$

$$\text{Given } 4 \cdot \left| \frac{a}{\sqrt{2}} \right| = 16$$

$$\Rightarrow |a| = 4\sqrt{2}$$

14. If the length of the perpendicular drawn from the point  $P(a, 4, 2)$ ,  $a > 0$  on the line  $\frac{x+1}{2} = \frac{y-3}{3} = \frac{z-1}{-1}$  is  $2\sqrt{6}$  units and  $Q(\alpha_1, \alpha_2, \alpha_3)$  is the image of the point  $P$  in this line, then  $a + \sum_{i=1}^3 \alpha_i$  is equal to :

- (A) 7                                      (B) 8  
(C) 12                                    (D) 14

**Answer (B)**

**Sol.**  $\because PR$  is perpendicular to given line, so

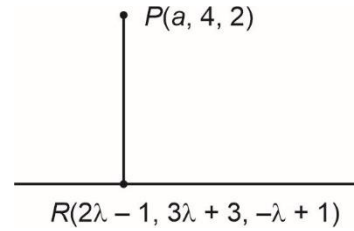

$$2(2\lambda - 1 - a) + 3(3\lambda - 1) - 1(-\lambda - 1) = 0$$

$$\Rightarrow a = 7\lambda - 2$$

Now

$$\because PR = 2\sqrt{6}$$

$$\Rightarrow (-5\lambda + 1)^2 + (3\lambda - 1)^2 + (\lambda + 1)^2 = 24$$

$$\Rightarrow 5\lambda^2 - 2\lambda - 3 = 0 \Rightarrow \lambda = 1 \text{ or } -\frac{3}{5}$$

$$\because a > 0 \text{ so } \lambda = 1 \text{ and } a = 5$$

$$\text{Now } \sum_{i=1}^3 \alpha_i = 2(\text{Sum of co-ordinate of } R)$$

$$- (\text{Sum of coordinates of } P)$$

$$= 2(7) - 11 = 3$$

$$a + \sum_{i=1}^3 \alpha_i = 5 + 3 = 8$$

15. If the line of intersection of the planes  $ax + by = 3$  and  $ax + by + cz = 0$ ,  $a > 0$  makes an angle  $30^\circ$  with the plane  $y - z + 2 = 0$ , then the direction cosines of the line are :

- (A)  $\frac{1}{\sqrt{2}}, \frac{1}{\sqrt{2}}, 0$                       (B)  $\frac{1}{\sqrt{2}}, -\frac{1}{\sqrt{2}}, 0$   
(C)  $\frac{1}{\sqrt{5}}, -\frac{2}{\sqrt{5}}, 0$                       (D)  $\frac{1}{2}, -\frac{\sqrt{3}}{2}, 0$

**Answer (B)**

**Sol.**  $P_1 : ax + by + 0z = 3$ , normal vector :  $\vec{n}_1 = (a, b, 0)$

$P_2 : ax + by + cz = 0$ , normal vector :  $\vec{n}_2 = (a, b, c)$

Vector parallel to the line of intersection =  $\vec{n}_1 \times \vec{n}_2$

$$\vec{n}_1 \times \vec{n}_2 = (bc, -ac, 0)$$

Vector normal to  $0 \cdot x + y - z + 2 = 0$  is

$$\vec{n}_3 = (0, 1, -1)$$





19. Let  $S = \left\{ \theta \in \left(0, \frac{\pi}{2}\right) : \sum_{m=1}^9 \sec\left(\theta + (m-1)\frac{\pi}{6}\right) \sec\left(\theta + \frac{m\pi}{6}\right) = -\frac{8}{\sqrt{3}} \right\}$ .

Then

(A)  $S = \left\{ \frac{\pi}{12} \right\}$                       (B)  $S = \left\{ \frac{2\pi}{3} \right\}$

(C)  $\sum_{\theta \in S} \theta = \frac{\pi}{2}$                       (D)  $\sum_{\theta \in S} \theta = \frac{3\pi}{4}$

**Answer (C)**

**Sol.**  $S = \left\{ \theta \in \left(0, \frac{\pi}{2}\right) : \sum_{m=1}^9 \sec\left(\theta + (m-1)\frac{\pi}{6}\right) \sec\left(\theta + \frac{m\pi}{6}\right) = -\frac{8}{\sqrt{3}} \right\}$ .

$$\sum_{m=1}^9 \frac{1}{\cos\left(\theta + (m-1)\frac{\pi}{6}\right)} \cos\left(\theta + m\frac{\pi}{6}\right)$$

$$\frac{1}{\sin\left(\frac{\pi}{6}\right)} \sum_{m=1}^9 \frac{\sin\left[\left(\theta + \frac{m\pi}{6}\right) - \left(\theta + (m-1)\frac{\pi}{6}\right)\right]}{\cos\left(\theta + (m-1)\frac{\pi}{6}\right) \cos\left(\theta + m\frac{\pi}{6}\right)}$$

$$= 2 \sum_{m=1}^9 \left[ \tan\left(\theta + \frac{m\pi}{6}\right) - \tan\left(\theta + (m-1)\frac{\pi}{6}\right) \right]$$

Now,  $m = 1$      $2 \left[ \tan\left(\theta + \frac{\pi}{6}\right) - \tan(\theta) \right]$

$m = 2$      $2 \left[ \tan\left(\theta + \frac{2\pi}{6}\right) - \tan\left(\theta + \frac{\pi}{6}\right) \right]$

⋮

$m = 9$      $2 \left[ \tan\left(\theta + \frac{9\pi}{6}\right) - \tan\left(\theta + 8\frac{\pi}{6}\right) \right]$

$$\therefore = 2 \left[ \tan\left(\theta + \frac{3\pi}{2}\right) - \tan\theta \right] = \frac{-8}{\sqrt{3}}$$

$$= -2[\cot\theta + \tan\theta] = \frac{-8}{\sqrt{3}}$$

$$= -\frac{2 \times 2}{2\sin\theta\cos\theta} = \frac{-8}{\sqrt{3}}$$

$$= \frac{1}{\sin 2\theta} = \frac{2}{\sqrt{3}}$$

$$\Rightarrow \sin 2\theta = \frac{\sqrt{3}}{2}$$

$$2\theta = \frac{\pi}{3} \quad 2\theta = \frac{2\pi}{3}$$

$$\theta = \frac{\pi}{6} \quad \theta = \frac{\pi}{3}$$

$$\sum \theta_i = \frac{\pi}{6} + \frac{\pi}{3} = \frac{\pi}{2}$$

20. If the truth value of the statement  $(P \wedge (\sim R)) \rightarrow ((\sim R) \wedge Q)$  is  $F$ , then the truth value of which of the following is  $F$ ?

- (A)  $P \vee Q \rightarrow \sim R$   
 (B)  $R \vee Q \rightarrow \sim P$   
 (C)  $\sim (P \vee Q) \rightarrow \sim R$   
 (D)  $\sim (R \vee Q) \rightarrow \sim P$

**Answer (D)**

**Sol.**  $\underbrace{P \wedge (\sim R)}_X \rightarrow \underbrace{((\sim R) \wedge Q)}_Y = \text{False}$

$X \rightarrow Y = \text{False}$

$X \quad Y \quad X \rightarrow Y$

$F \quad F \quad T$

$T \quad T \quad T$

$F \quad T \quad T$

$T \quad F \quad F$

$P \wedge \sim R = T$  and  $(\sim R) \wedge Q = F$

$\Rightarrow P = T$

$\sim R = T \Rightarrow R = F$

$\Rightarrow P = T, Q = F$  and  $R = F$

$T \wedge Q = F$

$\Rightarrow Q = F$

Now  $\sim(R \vee Q) \rightarrow \sim P$

$\sim(F \vee F) \rightarrow F$

$F \rightarrow F = \text{False}$

**SECTION - B**

**Numerical Value Type Questions:** This section contains 10 questions. In Section B, attempt any five questions out of 10. The answer to each question is a **NUMERICAL VALUE**. For each question, enter the correct numerical value (in decimal notation, truncated/rounded-off to the second decimal place; e.g. 06.25, 07.00, -00.33, -00.30, 30.27, -27.30) using the mouse and the on-screen virtual numeric keypad in the place designated to enter the answer.

1. Consider a matrix  $A = \begin{bmatrix} \alpha & \beta & \gamma \\ \alpha^2 & \beta^2 & \gamma^2 \\ \beta + \gamma & \gamma + \alpha & \alpha + \beta \end{bmatrix}$ , where

$\alpha, \beta, \gamma$  are three distinct natural numbers.

If  $\frac{\det(\text{adj}(\text{adj}(\text{adj}(\text{adj} A))))}{(\alpha - \beta)^{16} (\beta - \gamma)^{16} (\gamma - \alpha)^{16}} = 2^{32} \times 3^{16}$ , then the

number of such 3-tuples  $(\alpha, \beta, \gamma)$  is \_\_\_\_\_.

**Answer (42)**

**Sol.**  $\det(A) = \begin{vmatrix} \alpha & \beta & \gamma \\ \alpha^2 & \beta^2 & \gamma^2 \\ \beta + \gamma & \gamma + \alpha & \alpha + \beta \end{vmatrix}$

$R_3 \rightarrow R_3 + R_1$

$\Rightarrow (\alpha + \beta + \gamma) \begin{vmatrix} \alpha & \beta & \gamma \\ \alpha^2 & \beta^2 & \gamma^2 \\ 1 & 1 & 1 \end{vmatrix}$

$\therefore \det(A) = (\alpha + \beta + \gamma) (\alpha - \beta) (\beta - \gamma) (\gamma - \alpha)$

Also,  $\det(\text{adj}(\text{adj}(\text{adj}(\text{adj}(A))))))$

$= (\det(A))^{2^4} = (\det(A))^{16}$

$\therefore \frac{(\alpha + \beta + \gamma)^{16} (\alpha - \beta)^{16} (\beta - \gamma)^{16} (\gamma - \alpha)^{16}}{(\alpha - \beta)^{16} (\beta - \gamma)^{16} (\gamma - \alpha)^{16}} = (4.3)^{16}$

$\Rightarrow \alpha + \beta + \gamma = 12$

$\Rightarrow (\alpha, \beta, \gamma)$  distinct natural triplets

$= {}^{11}C_2 - 1 - {}^3C_2(4) = 55 - 1 - 12$

$= 42$

2. The number of functions  $f$ , from the set  $A = \{x \in N : x^2 - 10x + 9 \leq 0\}$  to the set  $B = \{n^2 : n \in N\}$  such that  $f(x) \leq (x - 3)^2 + 1$ , for every  $x \in A$ , is \_\_\_\_\_.

**Answer (1440)**

**Sol.**  $A = \{x \in N, x^2 - 10x + 9 \leq 0\}$

$= \{1, 2, 3, \dots, 9\}$

$B = \{1, 4, 9, 16, \dots\}$

$f(x) \leq (x - 3)^2 + 1$

$f(1) \leq 5, f(2) \leq 2, \dots, f(9) \leq 37$

$x = 1$  has 2 choices

$x = 2$  has 1 choice

$x = 3$  has 1 choice

$x = 4$  has 1 choice

$x = 5$  has 2 choices

$x = 6$  has 3 choices

$x = 7$  has 4 choices

$x = 8$  has 5 choices

$x = 9$  has 6 choices

$\therefore$  Total functions  $= 2 \times 1 \times 1 \times 1 \times 2 \times 3 \times 4 \times 5 \times 6 = 1440$

3. Let for the 9<sup>th</sup> term in the binomial expansion of  $(3 + 6x)^n$ , in the increasing powers of  $6x$ , to be the greatest for  $x = \frac{3}{2}$ , the least value of  $n$  is  $n_0$ . If  $k$  is

the ratio of the coefficient of  $x^6$  to the coefficient of  $x^3$ , then  $k + n_0$  is equal to :

**Answer (24)**

**Sol.**  $(3 + 6x)^n = 3^n (1 + 2x)^n$

If  $T_9$  is numerically greatest term

$\therefore T_8 \leq T_9 \geq T_{10}$

${}^nC_7 3^{n-7} (6x)^7 \leq {}^nC_8 3^{n-8} (6x)^8 \geq {}^nC_9 3^{n-9} (6x)^9$

$\Rightarrow \frac{n!}{(n-7)!7!} 9 \leq \frac{n!}{(n-8)!8!} 3 \cdot (6x) \geq \frac{n!}{(n-9)!9!} (6x)^2$

$\Rightarrow \frac{9}{(n-7)(n-8)} \leq \frac{18 \left(\frac{3}{2}\right)}{(n-8)8} \geq \frac{36}{9.8.4}$

$72 \leq 27(n-7)$  and  $27 \geq 9(n-8)$

$\frac{29}{3} \leq n$  and  $n \leq 11$

$\therefore n_0 = 10$

For  $(3 + 6x)^{10}$

$T_{r+1} = {}^{10}C_r 3^{10-r} (6x)^r$

For coeff. of  $x^6$

$r = 6 \Rightarrow {}^{10}C_6 3^4 \cdot 6^6$

For coeff. of  $x^3$

$r = 3 \Rightarrow {}^{10}C_3 3^7 \cdot 6^3$

$\therefore k = \frac{{}^{10}C_6 \cdot 3^4 \cdot 6^6}{{}^{10}C_3 \cdot 3^7 \cdot 6^3} = \frac{10! 7! 3!}{6! 4! 10!} \cdot 8$

$\Rightarrow k = 14$

$\therefore k + n_0 = 24$

4.  $\frac{2^3 - 1^3}{1 \times 7} + \frac{4^3 - 3^3 + 2^2 - 1^3}{2 \times 11} + \frac{6^3 - 5^3 + 4^3 - 3^3 + 2^3 - 1^3}{3 \times 15}$   
 $+ \dots + \frac{30^3 - 29^3 + 28^3 - 27^3 + \dots + 2^3 - 1^3}{15 \times 63}$  is equal  
 to \_\_\_\_\_.

**Answer (120)**

**Sol.**  $T_n = \frac{\sum_{k=1}^n [(2k)^3 - (2k-1)^3]}{n(4n+3)}$

$$= \frac{\sum_{k=1}^n 4k^2 + (2k-1)^2 + 2k(2k-1)}{n(4n+3)}$$

$$= \frac{\sum_{k=1}^n (12k^2 - 6k + 1)}{n(4n+3)}$$

$$= \frac{2n(2n^2 + 3n + 1) - 3n^2 - 3n + n}{n(4n+3)}$$

$$= \frac{n^2(4n+3)}{n(4n+3)} = n$$

$\therefore T_n = n$

$S_n = \sum_{n=1}^{15} T_n = \frac{15 \times 16}{2} = 120$

5. A water tank has the shape of a right circular cone with axis vertical and vertex downwards. Its semi-vertical angle is  $\tan^{-1} \frac{3}{4}$ . Water is poured in it at a constant rate of 6 cubic meter per hour. The rate (in square meter per hour), at which the wet curved surface area of the tank is increasing, when the depth of water in the tank is 4 meters, is

**Answer (5)**

**Sol.**

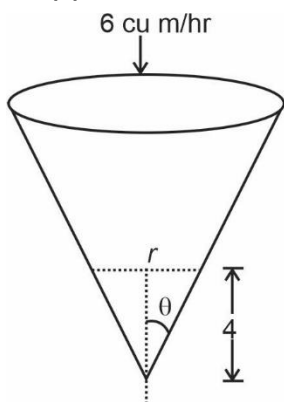

$\tan \theta = 3/4$

$v = \frac{1}{3} \pi r^2 h$  ... (i)

And  $\tan \theta = \frac{3}{4} = \frac{r}{h}$  ... (ii)

i.e. if  $h = 4, r = 3$

$v = \frac{1}{3} \pi r^2 \left( \frac{4r}{3} \right)$

$\frac{dv}{dt} = \frac{4\pi}{9} 3r^2 \frac{dr}{dt} \Rightarrow 6 = \frac{4\pi}{3} (9) \frac{dr}{dt}$

$\Rightarrow \frac{dr}{dt} = \frac{1}{2\pi}$

Curved area =  $\pi r \sqrt{r^2 + h^2}$

$= \pi r \sqrt{r^2 + \frac{16r^2}{9}}$

$= \frac{5}{3} \pi r^2$

$\frac{dA}{dt} = \frac{10}{3} \pi r \frac{dr}{dt}$

$= \frac{10}{3} \pi \cdot 3 \cdot \frac{1}{2\pi}$

$= 5$

6. For the curve  $C : (x^2 + y^2 - 3) + (x^2 - y^2 - 1)^5 = 0$ , the value of  $3y - y^3 y'$ , at the point  $(\alpha, \alpha), \alpha > 0$ , on  $C$  is equal to \_\_\_\_\_.

**Answer (16)**

**Sol.**  $\therefore C : (x^2 + y^2 - 3) + (x^2 - y^2 - 1)^5 = 0$  for point  $(\alpha, \alpha)$ .

$\alpha^2 + \alpha^2 - 3 + (\alpha^2 - \alpha^2 - 1)^5 = 0$

$\therefore \alpha = \sqrt{2}$ .

On differentiating  $(x^2 + y^2 - 3) + (x^2 - y^2 - 1)^5 = 0$  we get

$x + yy' + 5(x^2 - y^2 - 1)^4 (x - yy') = 0$  ... (i)

When  $x = y = \sqrt{2}$  then  $y' = \frac{3}{2}$ .

Again on differentiating eq. (i) we get :

$1 + (y')^2 + yy'' + 20(x^2 - y^2 - 1)(2x - 2yy')$   
 $(x - yy') + 5(x^2 - y^2 - 1)^4 (1 - y^2 - yy'') = 0$

For  $x = y = \sqrt{2}$  and  $y' = \frac{3}{2}$  we get  $y'' = -\frac{23}{4\sqrt{2}}$

$\therefore 3y - y^3 y'' = 3 \cdot \frac{3}{2} - (\sqrt{2})^3 \cdot \left( -\frac{23}{4\sqrt{2}} \right)$

$= 16$

7. Let  $f(x) = \min \{[x-1], [x-2], \dots, [x-10]\}$  where  $[t]$  denotes the greatest integer  $\leq t$ . Then  $\int_0^{10} f(x) dx + \int_0^{10} (f(x))^2 dx + \int_0^{10} |f(x)| dx$  is equal to \_\_\_\_\_.

**Answer (385)**

**Sol.**  $\therefore f(x) = \min \{[x-1], [x-2], \dots, [x-10]\} = [x-10]$

$$\text{Also } |f(x)| = \begin{cases} -f(x), & \text{if } x \leq 10 \\ f(x), & \text{if } x \geq 10 \end{cases}$$

$$\begin{aligned} \therefore \int_0^{10} f(x) dx + \int_0^{10} (f(x))^2 dx + \int_0^{10} (-f(x)) dx \\ = \int_0^{10} (f(x))^2 dx \\ = 10^2 + 9^2 + 8^2 + \dots + 1^2 \\ = \frac{10 \times 11 \times 21}{6} \\ = 385 \end{aligned}$$

8. Let  $f$  be a differential function satisfying

$$f(x) = \frac{2}{\sqrt{3}} \int_0^{\sqrt{3}} f\left(\frac{\lambda^2 x}{3}\right) d\lambda, x > 0 \text{ and } f(1) = \sqrt{3}. \text{ If}$$

$y = f(x)$  passes through the point  $(\alpha, 6)$ , then  $\alpha$  is equal to \_\_\_\_\_

**Answer (12)**

**Sol.**  $\therefore f(x) = \frac{2}{\sqrt{3}} \int_0^{\sqrt{3}} f\left(\frac{\lambda^2 x}{3}\right) d\lambda, x > 0 \dots(i)$

On differentiating both sides w.r.t.,  $x$ , we get

$$f'(x) = \frac{2}{\sqrt{3}} \int_0^{\sqrt{3}} \frac{\lambda^2}{3} f'\left(\frac{\lambda^2 x}{3}\right) d\lambda$$

$$f'(x) = \frac{1}{\sqrt{3}} \int_0^{\sqrt{3}} \lambda \cdot \frac{2\lambda}{3} f'\left(\frac{\lambda^2 x}{3}\right) d\lambda$$

$$\therefore \sqrt{3} f'(x) = \left[ \frac{\lambda}{x} \cdot f\left(\frac{\lambda^2 x}{3}\right) \right]_0^{\sqrt{3}} - \int_0^{\sqrt{3}} \frac{1}{x} f\left(\frac{\lambda^2 x}{3}\right) dx$$

$$\sqrt{3} x f'(x) = \sqrt{3} f(x) - \frac{\sqrt{3}}{2} f(x)$$

$$x f'(x) = \frac{f(x)}{2}$$

On integrating we get :  $\ln y = \frac{1}{2} \ln x + \ln c$

$$\therefore f(1) = \sqrt{3} \text{ then } c = \sqrt{3}$$

$\therefore (\alpha, 6)$  lies on

$$\therefore y = \sqrt{3x}$$

$$\therefore 6 = \sqrt{3\alpha} \Rightarrow \alpha = 12.$$

9. A common tangent  $T$  to the curves  $C_1 : \frac{x^2}{4} + \frac{y^2}{9} = 1$

and  $C_2 : \frac{x^2}{42} - \frac{y^2}{143} = 1$  does not pass through the fourth quadrant. If  $T$  touches  $C_1$  at  $(x_1, y_1)$  and  $C_2$  at  $(x_2, y_2)$ , then  $|2x_1 + x_2|$  is equal to \_\_\_\_\_.

**Answer (20)**

**Sol.** Equation of tangent to ellipse  $\frac{x^2}{4} + \frac{y^2}{9} = 1$  and

$$\text{given slope } m \text{ is : } y = mx + \sqrt{4m^2 + 9} \dots(i)$$

For slope  $m$  equation of tangent to hyperbola is :

$$y = mx + \sqrt{42m^2 - 143} \dots(ii)$$

Tangents from (i) and (ii) are identical then

$$4m^2 + 9 = 42m^2 - 143$$

$$\therefore m = \pm 2 \quad (+2 \text{ is not acceptable})$$

$$\therefore m = -2.$$

$$\text{Hence } x_1 = \frac{8}{5} \text{ and } x_2 = \frac{84}{5}$$

$$\therefore |2x_1 + x_2| = \left| \frac{16}{5} + \frac{84}{5} \right| = 20$$

10. Let  $\vec{a}, \vec{b}, \vec{c}$  be three non-coplanar vectors such that

$$\vec{a} \times \vec{b} = 4\vec{c}, \vec{b} \times \vec{c} = 9\vec{a} \text{ and } \vec{c} \times \vec{a} = \alpha\vec{b}, \alpha > 0. \text{ If}$$

$$|\vec{a}| + |\vec{b}| + |\vec{c}| = \frac{1}{36}, \text{ then } \alpha \text{ is equal to _____.}$$

**Answer (\*)**

**Sol.** Given  $\vec{a} \times \vec{b} = 4 \cdot \vec{c} \dots(i)$

$$\vec{b} \times \vec{c} = 9 \cdot \vec{a} \dots(ii)$$

$$\vec{c} \times \vec{a} = \alpha \cdot \vec{b} \dots(iii)$$

Taking dot products with  $\vec{c}, \vec{a}, \vec{b}$  we get

$$\vec{a} \cdot \vec{b} = \vec{b} \cdot \vec{c} = \vec{c} \cdot \vec{a} = 0$$

Hence (i)  $\Rightarrow |\vec{a}| \cdot |\vec{b}| = 4 \cdot |\vec{c}| \quad \dots(\text{iv})$

(ii)  $\Rightarrow |\vec{b}| \cdot |\vec{c}| = 9 \cdot |\vec{a}| \quad \dots(\text{v})$

(iii)  $\Rightarrow |\vec{c}| \cdot |\vec{a}| = \alpha \cdot |\vec{b}| \quad \dots(\text{vi})$

Multiplying (iv), (v) and (vi)

$\Rightarrow |\vec{a}| \cdot |\vec{b}| \cdot |\vec{c}| = 36\alpha \quad \dots(\text{vii})$

Dividing (vii) by (iv)  $\Rightarrow |\vec{c}|^2 = 9\alpha \Rightarrow |\vec{c}| = 3\sqrt{\alpha}$

$\dots(\text{viii})$

Dividing (vii) by (v)  $\Rightarrow |\vec{a}|^2 = 4\alpha \Rightarrow |\vec{a}| = 2\sqrt{\alpha}$

Dividing (vii) by (vi)  $\Rightarrow |\vec{b}|^2 = 36 \Rightarrow |\vec{b}| = 6$

Now, as given,  $3\sqrt{\alpha} + 2\sqrt{\alpha} + 6 = \frac{1}{36} \Rightarrow \sqrt{\alpha} = \frac{-43}{36}$

□ □ □

