

29/07/2022

Morning



Corporate Office : Aakash Tower, 8, Pusa Road, New Delhi-110005 | Ph.: 011-47623456

Answers & Solutions

Time : 3 hrs.

for

M.M. : 300

JEE (Main)-2022 (Online) Phase-2

(Physics, Chemistry and Mathematics)

IMPORTANT INSTRUCTIONS:

- (1) The test is of **3 hours** duration.
- (2) The Test Booklet consists of 90 questions. The maximum marks are 300.
- (3) There are **three** parts in the question paper consisting of **Physics, Chemistry** and **Mathematics** having 30 questions in each part of equal weightage. Each part (subject) has two sections.
 - (i) **Section-A:** This section contains 20 multiple choice questions which have only one correct answer. Each question carries **4 marks** for correct answer and **-1 mark** for wrong answer.
 - (ii) **Section-B:** This section contains 10 questions. In Section-B, attempt any **five questions out of 10**. The answer to each of the questions is a numerical value. Each question carries **4 marks** for correct answer and **-1 mark** for wrong answer. For Section-B, the answer should be rounded off to the nearest integer.

PHYSICS

SECTION - A

Multiple Choice Questions: This section contains 20 multiple choice questions. Each question has 4 choices (1), (2), (3) and (4), out of which **ONLY ONE** is correct.

Choose the correct answer :

1. Given below are two statements: One is labelled as **Assertion (A)** and other is labelled as **Reason (R)**.

Assertion (A) : Time period of oscillation of a liquid drop depends on surface tension (S), if density of the liquid is ρ and radius of the drop is r , then

$T = K\sqrt{\frac{\rho r^3}{S^{3/2}}}$ is dimensionally correct, where K is dimensionless.

Reason (R) : Using dimensional analysis we get R.H.S. having different dimension than that of time period.

In the light of above statements, choose the correct answer from the options given below.

- (A) Both (A) and (R) are true and (R) is the correct explanation of (A)
- (B) Both (A) and (R) are true but (R) is not the correct explanation of (A)
- (C) (A) is true but (R) is false
- (D) (A) is false but (R) is true

Answer (D)

Sol. $\left[\frac{\rho r^3}{T^{3/2}}\right] = \frac{[ML^{-3}][L^3]}{[ML^{-1}T^{-2}]^{3/2}} \neq [T]$

As the equation for first statement is wrong dimensionally.

\Rightarrow A is false and R is true

2. A ball is thrown up vertically with a certain velocity so that, it reaches a maximum height h . Find the ratio of the times in which it is at height $\frac{h}{3}$ while going up and coming down respectively

- (A) $\frac{\sqrt{2}-1}{\sqrt{2}+1}$
- (B) $\frac{\sqrt{3}-\sqrt{2}}{\sqrt{3}+\sqrt{2}}$
- (C) $\frac{\sqrt{3}-1}{\sqrt{3}+1}$
- (D) $\frac{1}{3}$

Answer (B)

Sol. $v = \sqrt{2gh}$

$$\frac{h}{3} = \sqrt{2gh} t - \frac{1}{2}gt^2$$

$$\frac{g}{2}t^2 - \sqrt{2gh} t + \frac{h}{3} = 0$$

$$\frac{t_1}{t_2} = \frac{\sqrt{2gh} + \sqrt{2gh - 2gh/3}}{\sqrt{2gh} - \sqrt{2gh - 2gh/3}}$$

$$= \frac{\sqrt{2} + \frac{2}{\sqrt{3}}}{\sqrt{2} - \frac{2}{\sqrt{3}}} = \frac{\sqrt{3} + \sqrt{2}}{\sqrt{3} - \sqrt{2}}$$

3. If $t = \sqrt{x} + 4$, then $\left(\frac{dx}{dt}\right)_{t=4}$ is

- (A) 4
- (B) Zero
- (C) 8
- (D) 16

Answer (B)

Sol. $x = (t - 4)^2$

$$\frac{dx}{dt} = 2t - 8 = 0$$

4. A smooth circular groove has a smooth vertical wall as shown in figure. A block of mass m moves against the wall with a speed v . Which of the following curve represents the correct relation between the normal reaction on the block by the wall (N) and speed of the block (v)?

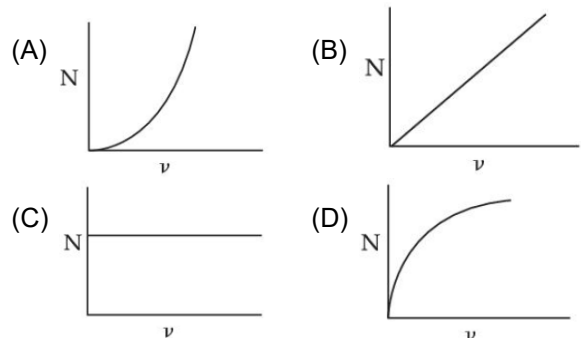
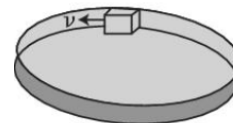

Answer (A)

Sol. $N = \frac{mv^2}{r}$

\Rightarrow The graph given in option A suits the best for the above relation.

5. A ball is projected with kinetic energy E , at an angle of 60° to the horizontal. The kinetic energy of this ball at the highest point of its flight will become

- (A) Zero (B) $\frac{E}{2}$
 (C) $\frac{E}{4}$ (D) E

Answer (C)

Sol. $K \cdot E = E = \frac{1}{2}mv^2$

at highest point

$$K \cdot E' = \frac{1}{2}mv^2 \cos^2 \theta$$

$$= \frac{1}{2}mv^2 \left(\frac{1}{4}\right)$$

$$= \frac{E}{4}$$

6. Two bodies of mass 1 kg and 3 kg have position vectors $\hat{i} + 2\hat{j} + \hat{k}$ and $-3\hat{i} - 2\hat{j} + \hat{k}$ respectively. The magnitude of position vector of centre of mass of this system will be similar to the magnitude of vector :

- (A) $\hat{i} + 2\hat{j} + \hat{k}$
 (B) $-3\hat{i} - 2\hat{j} + \hat{k}$
 (C) $-2\hat{j} + 2\hat{k}$
 (D) $-2\hat{i} - \hat{j} + 2\hat{k}$

Answer (A)

Sol. $\vec{r}_{com} = \frac{m_1\vec{r}_1 + m_2\vec{r}_2}{m_1 + m_2}$

$$= \frac{(1-9)\hat{i} + (2-6)\hat{j} + (1+3)\hat{k}}{4}$$

$$= \frac{-8\hat{i} - 4\hat{j} + 4\hat{k}}{4}$$

$$\vec{r}_{com} = -2\hat{i} - \hat{j} + \hat{k}$$

$$|\vec{r}| = \sqrt{4+1+1} = \sqrt{6}$$

$$|\hat{i} + 2\hat{j} + \hat{k}| = \sqrt{6}$$

7. Given below are two statements: One is labelled as **Assertion (A)** and the other is labelled as **Reason (R)**.

Assertion (A) : Clothes containing oil or grease stains cannot be cleaned by water wash.

Reason (R) : Because the angle of contact between the oil/ grease and water is obtuse.

In the light of the above statements, choose the correct answer from the option given below.

- (A) Both **(A)** and **(R)** are true and **(R)** is the correct explanation of **(A)**
 (B) Both **(A)** and **(R)** are true but **(R)** is not the correct explanation of **(A)**
 (C) **(A)** is true but **(R)** is false
 (D) **(A)** is false but **(R)** is true

Answer (A)

Sol. Due to obtuse angle of contact the water doesn't wet the oiled surface properly and cannot wash it also.

\Rightarrow Assertion is correct and Reason given is a correct explanation.

8. If the length of a wire is made double and radius is halved of its respective values. Then, the Young's modulus of the material of the wire will :

- (A) remain same
 (B) become 8 times its initial value
 (C) become $\frac{1}{4}$ th of its initial value
 (D) become 4 times its initial value

Answer (A)

Sol. young's modulus of matter depends on material of wire and is independent of the dimensions of the wire. As the material remains same so Young's modulus also remain same.

9. The time period of oscillation of a simple pendulum of length L suspended from the roof of a vehicle, which moves without friction down an inclined plane of inclination α , is given by:

- (A) $2\pi\sqrt{L/(g \cos \alpha)}$ (B) $2\pi\sqrt{L/(g \sin \alpha)}$
 (C) $2\pi\sqrt{L/g}$ (D) $2\pi\sqrt{L/(g \tan \alpha)}$

Answer (A)

Sol. $|g_{eff}| = |\bar{g} - \bar{a}|$

$$\Rightarrow g_{eff} = g \cos \theta$$

$$\Rightarrow T = 2\pi \sqrt{\frac{l}{g_{eff}}}$$

$$= 2\pi \sqrt{\frac{L}{g \cos \theta}}$$

10. A spherically symmetric charge distribution is considered with charge density varying as

$$\rho(r) = \begin{cases} \rho_0 \left(\frac{3}{4} - \frac{r}{R} \right) & \text{for } r \leq R \\ \text{zero} & \text{for } r > R \end{cases}$$

Where, $r (r < R)$ is the distance from the centre O (as shown in figure) The electric field at point P will be :

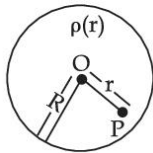

- (A) $\frac{\rho_0 r}{4\epsilon_0} \left(\frac{3}{4} - \frac{r}{R} \right)$ (B) $\frac{\rho_0 r}{3\epsilon_0} \left(\frac{3}{4} - \frac{r}{R} \right)$
- (C) $\frac{\rho_0 r}{4\epsilon_0} \left(1 - \frac{r}{R} \right)$ (D) $\frac{\rho_0 r}{5\epsilon_0} \left(1 - \frac{r}{R} \right)$

Answer (C)

Sol. $(4\pi r^2)E_p = \frac{Q_{in}}{\epsilon_0}$

$$= \frac{\int_0^r \rho_0 \left(\frac{3}{4} - \frac{r}{R} \right) 4\pi r^2 dr}{\epsilon_0}$$

$$= \frac{\rho_0 \pi 4 \left(\frac{r^3}{4} - \frac{r^4}{4R} \right)}{\epsilon_0}$$

$$E_p = \frac{\rho_0}{4\epsilon_0} \left(r - \frac{r^2}{R} \right)$$

$$= \frac{\rho_0 r}{4\epsilon_0} \left(1 - \frac{r}{R} \right)$$

11. Given below are two statements.

Statement I : Electric potential is constant within and at the surface of each conductor.

Statement II : Electric field just outside a charged conductor is perpendicular to the surface of the conductor at every point.

In the light of the above statements, choose the most appropriate answer from the options given below.

- (A) Both statement I and statement II are correct
 (B) Both statement I and statement II are incorrect
 (C) Statement I is correct but statement II is incorrect
 (D) Statement I is incorrect but statement II is correct

Answer (A)

Sol. Since $\vec{E}_{net} = \vec{0}$ in the bulk of a conductor

\Rightarrow Potential would be constant.

\Rightarrow Statement I is correct.

Since a conductor's surface is equipotential, \vec{E} just outside is perpendicular to the surface.

12. Two metallic wires of identical dimensions are connected in series. If σ_1 and σ_2 are the conductivities of these wires respectively, the effective conductivity of the combination is :

- (A) $\frac{\sigma_1 \sigma_2}{\sigma_1 + \sigma_2}$ (B) $\frac{2\sigma_1 \sigma_2}{\sigma_1 + \sigma_2}$
- (C) $\frac{\sigma_1 + \sigma_2}{2\sigma_1 \sigma_2}$ (D) $\frac{\sigma_1 + \sigma_2}{\sigma_1 \sigma_2}$

Answer (B)

Sol. $R = R_1 + R_2$

$$\Rightarrow \frac{l_1 + l_2}{\sigma A} = \frac{l_1}{\sigma_1 A} + \frac{l_2}{\sigma_2 A}$$

$$\Rightarrow \frac{2}{\sigma} = \frac{1}{\sigma_1} + \frac{1}{\sigma_2}$$

$$\Rightarrow \sigma = \frac{2\sigma_1 \sigma_2}{\sigma_1 + \sigma_2}$$

13. An alternating emf $E = 440 \sin 100\pi t$ is applied to a circuit containing an inductance of $\frac{\sqrt{2}}{\pi}$ H.

If an a.c. ammeter is connected in the circuit, its reading will be :

- (A) 4.4 A (B) 1.55 A
(C) 2.2 A (D) 3.11 A

Answer (C)

Sol. $I = \frac{V}{\omega L}$

$$= \frac{440}{100\pi \times \frac{\sqrt{2}}{\pi}} = \frac{44}{10\sqrt{2}}$$

$$\Rightarrow I_{\text{rms}} = \frac{I}{\sqrt{2}} = \frac{44}{20} = 2.2 \text{ A}$$

14. A coil of inductance 1 H and resistance 100 Ω is connected to a battery of 6 V. Determine approximately :

- (a) The time elapsed before the current acquires half of its steady – state value.
(b) The energy stored in the magnetic field associated with the coil at an instant 15 ms after the circuit is switched on.

(Given $\ln 2 = 0.693$, $e^{-3/2} = 0.25$)

- (A) $t = 10$ ms; $U = 2$ mJ (B) $t = 10$ ms; $U = 1$ mJ
(C) $t = 7$ ms; $U = 1$ mJ (D) $t = 7$ ms; $U = 2$ mJ

Answer (C)

Sol. $i(t) = \frac{V}{R}(1 - e^{-Rt/L})$... (1)

$$\frac{L}{R} = \frac{1}{100} \text{ s} \Rightarrow \frac{L}{R} = 10 \text{ ms} \dots (2)$$

$$\frac{V}{2R} = \frac{V}{R}(1 - e^{-Rt/L})$$

$$\Rightarrow e^{-Rt/L} = \frac{1}{2} \Rightarrow t = \frac{L}{R} \ln 2 = 6.93 \text{ ms}$$

$$U = \frac{1}{2} Li^2 = \frac{1}{2} [1 - e^{-15/10}]^2 \left[\frac{6}{100} \right]^2$$

$$= \frac{1}{2} [1 - 0.25]^2 \times 36 \times 10^{-4}$$

$$= 1 \text{ mJ}$$

15. Match **List-I** with **List-II**:

- | List-I | List-II |
|-------------------|---|
| (a) UV rays | (i) Diagnostic tool in medicine |
| (b) X-rays | (ii) Water purification |
| (c) Microwave | (iii) Communication, Radar |
| (d) Infrared wave | (iv) Improving visibility in foggy days |

Choose the correct answer from the options given below :

- (A) (a)-(iii), (b)-(ii), (c)-(i), (d)-(iv)
(B) (a)-(ii), (b)-(i), (c)-(iii), (d)-(iv)
(C) (a)-(ii), (b)-(iv), (c)-(iii), (d)-(i)
(D) (a)-(iii), (b)-(i), (c)-(ii), (d)-(iv)

Answer (B)

Sol. UV – Water purification

X-rays – Diagnostic tool in medicine

Microwave – Communication, Radar

Infrared wave – Improving visibility in foggy days.

16. The kinetic energy of emitted electron is E when the light incident on the metal has wavelength λ . To double the kinetic energy, the incident light must have wavelength :

- (A) $\frac{hc}{E\lambda - hc}$ (B) $\frac{hc\lambda}{E\lambda + hc}$
(C) $\frac{h\lambda}{E\lambda + hc}$ (D) $\frac{hc\lambda}{E\lambda - hc}$

Answer (B)

Sol. $k = \frac{hc}{\lambda} - \phi = E$

and, $2k = \frac{hc}{\lambda_2} - \phi = 2E$

$$\Rightarrow \frac{hc}{\lambda} - E = \frac{hc}{\lambda_2} - 2E$$

$$\Rightarrow \frac{hc}{\lambda_2} = \frac{hc}{\lambda} + E$$

$$\Rightarrow \lambda_2 = \frac{hc\lambda}{hc + \lambda E}$$

17. Find the ratio of energies of photons produced due to transition of an electron of hydrogen atom from its (i) second permitted energy level to the first level, and (ii) the highest permitted energy level to the first permitted level.

- (A) 3 : 4
- (B) 4 : 3
- (C) 1 : 4
- (D) 4 : 1

Answer (A)

Sol. $E_1 = E_0 \left(\frac{1}{1^2} - \frac{1}{2^2} \right) = E_0 \times \frac{3}{4}$

$E_2 = E_0$

$\therefore \frac{E_1}{E_2} = \frac{3}{4}$

18. Find the modulation index of an AM wave having 8 V variation where maximum amplitude of the AM wave is 9 V.

- (A) 0.8
- (B) 0.5
- (C) 0.2
- (D) 0.1

Answer (A)

Sol. $\mu = \frac{\frac{8}{2}}{\left(9 - \frac{8}{2} \right)} = \frac{4}{5} = 0.8$

19. A travelling microscope has 20 divisions per cm on the main scale while its vernier scale has total 50 divisions and 25 vernier scale divisions are equal to 24 main scale divisions, what is the least count of the travelling microscope?

- (A) 0.001 cm
- (B) 0.002 mm
- (C) 0.002 cm
- (D) 0.005 cm

Answer (C)

Sol. $1 \text{ MSD} = \frac{1}{20} \text{ cm}$

$1 \text{ VSD} = \frac{24}{25} \times \frac{1}{20} \text{ cm}$

$\therefore \text{Least count} = 1 \text{ MSD} - 1 \text{ VSD}$

$= \frac{1}{20} \left(1 - \frac{24}{25} \right) \text{ cm}$

$= \frac{1}{20} \times \frac{1}{25} \text{ cm}$

$= 0.002 \text{ cm}$

20. In an experiment to find out the diameter of wire using screw gauge, the following observations were noted :

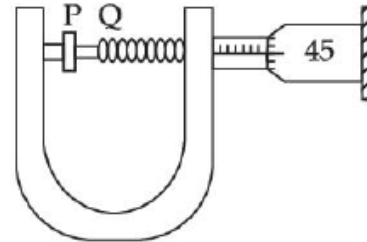

- (A) Screw moves 0.5 mm on main scale in one complete rotation
- (B) Total divisions on circular scale = 50
- (C) Main scale reading is 2.5 mm
- (D) 45th division of circular scale is in the pitch line
- (E) Instrument has 0.03 mm negative error

Then the diameter of wire is :

- (A) 2.92 mm
- (B) 2.54 mm
- (C) 2.98 mm
- (D) 3.45 mm

Answer (C)

Sol. $L.C. = \frac{0.5}{50} \text{ mm} = 0.01 \text{ mm}$

$d = (2.5 + 45 \times 0.01 + 0.03) \text{ mm}$

$= 2.98$

SECTION - B

Numerical Value Type Questions: This section contains 10 questions. In Section B, attempt any five questions out of 10. The answer to each question is a **NUMERICAL VALUE**. For each question, enter the correct numerical value (in decimal notation, truncated/rounded-off to the second decimal place; e.g. 06.25, 07.00, -00.33, -00.30, 30.27, -27.30) using the mouse and the on-screen virtual numeric keypad in the place designated to enter the answer.

1. An object is projected in the air with initial velocity u at an angle θ . The projectile motion is such that the horizontal range R , is maximum. Another object is projected in the air with a horizontal range half of the range of first object. The initial velocity remains same in both the case. The value of the angle of projection, at which the second object is projected, will be _____ degree.

Answer (15)

Sol. $\theta = 45^\circ$

$$R_1 = \frac{R}{2}$$

$$\frac{u^2 \sin 2\theta_1}{g} = \frac{u^2 \sin(90^\circ)}{2g}$$

$$\Rightarrow 2\theta_1 = 30^\circ$$

$$\theta_1 = 15^\circ$$

2. If the acceleration due to gravity experienced by a point mass at a height h above the surface of earth is same as that of the acceleration due to gravity at a depth αh ($h \ll R_e$) from the earth surface. The value of α will be _____.

(Use $R_e = 6400$ km)

Answer (2)

Sol. $g\left(1 - \frac{2h}{R}\right) = g\left(1 - \frac{d}{R}\right)$

$$\Rightarrow 2h = d$$

$$\Rightarrow \alpha = 2$$

3. The pressure P_1 and density d_1 of diatomic gas $\left(\gamma = \frac{7}{5}\right)$ changes suddenly to $P_2 (> P_1)$ and d_2 respectively during an adiabatic process. The temperature of the gas increases and becomes _____ times of its initial temperature.

(Given $\frac{d_2}{d_1} = 32$)

Answer (4)

Sol. $P_1 V_1^\gamma = P_2 V_2^\gamma$

$$\frac{P_1}{d_1^\gamma} = \frac{P_2}{d_2^\gamma}$$

$$\frac{d_1 T_1}{d_1^\gamma} = \frac{d_2 T_2}{d_2^\gamma}$$

$$T_2 = \left(\frac{d_2}{d_1}\right)^{\gamma-1} T_1$$

$$= (32)^{\frac{2}{5}} T_1$$

$$T_2 = 4 T_1$$

4. One mole of a monoatomic gas is mixed with three moles of a diatomic gas. The molecular specific heat of mixture at constant volume is $\frac{\alpha^2}{4} R$ J/mol K; then the value of α will be _____.
- (Assume that the given diatomic gas has no vibrational mode).

Answer (3)

Sol. $C_V = \frac{f}{2} R$

total degree of freedoms

$$= 1 \times 3 + 3 \times 5 = 18$$

$$\frac{\alpha^2}{4} = \frac{18}{2n} = \frac{18}{2 \times 4}$$

$$\Rightarrow \alpha^2 = 9$$

$$\alpha = 3$$

5. The current I flowing through the given circuit will be _____ A.

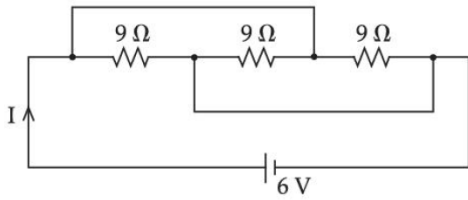

Answer (2)

Sol. All $9\ \Omega$ resistances are in parallel

$$R_{\text{eq}} = 3\ \Omega$$

$$I = \frac{6}{3} \text{ A} = 2 \text{ A}$$

6. A closely wound circular coil of radius 5 cm produces a magnetic field of 37.68×10^{-4} T at its center. The current through the coil is _____ A.

[Given, number of turns in the coil is 100 and $\pi = 3.14$]

Answer (3)

Sol. $B = \frac{\mu_0 n I}{2R}$

$$37.68 \times 10^{-4} = \frac{4\pi \times 10^{-7} \times 100 I}{2 \times 5 \times 10^{-2}}$$

$$I = \frac{300 \text{ A}}{100}$$

$$= 3 \text{ A}$$

7. Two light beams of intensities $4I$ and $9I$ interfere on a screen. The phase difference between these beams on the screen at point A is zero and at point B is π . The difference of resultant intensities, at the point A and B, will be _____ I .

Answer (24)

Sol. $I_A = (\sqrt{I_1} + \sqrt{I_2})^2 = 25I$

$$I_B = (\sqrt{I_1} - \sqrt{I_2})^2 = I$$

$$\text{So, } I_A - I_B = 24I$$

8. A wire of length 314 cm carrying current of 14 A is bent to form a circle. The magnetic moment of the coil is _____ A-m^2 . [Given $\pi = 3.14$]

Answer (11)

Sol. $R = \frac{l}{2\pi} = \frac{314}{2 \times 3.14} = 50 \text{ cm}$

$$\begin{aligned} \mu &= \pi R^2 i \\ &= 14 \times 3.14 \times (0.5)^2 \\ &= 11 \text{ A-m}^2 \end{aligned}$$

9. The X-Y plane be taken as the boundary between two transparent media M_1 and M_2 . M_1 in $Z \geq 0$ has a refractive index of $\sqrt{2}$ and M_2 with $Z < 0$ has a refractive index of $\sqrt{3}$. A ray of light travelling in M_1 along the direction given by the vector $\vec{P} = 4\sqrt{3}\hat{i} - 3\sqrt{3}\hat{j} - 5\hat{k}$, is incident on the plane of separation. The value of difference between the angle of incident in M_1 and the angle of refraction in M_2 will be _____ degree.

Answer (15)

Sol. Normal will be $-\hat{k}$ so

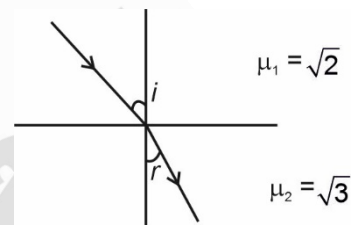

$$\cos i = \frac{\vec{P} \cdot \hat{n}}{|\vec{P}| \cdot |\hat{n}|}$$

$$\frac{5}{10} = \frac{1}{2}$$

$$\Rightarrow i = 60^\circ$$

and using snells law

$$\sqrt{2} \sin 60^\circ = \sqrt{3} \sin r$$

$$\frac{\sqrt{3}}{\sqrt{2}} = \sqrt{3} \sin r$$

$$\Rightarrow r = 45^\circ$$

$$\text{So, } i - r = 15^\circ$$

10. If the potential barrier across a p - n junction is 0.6 V. Then the electric field intensity, in the depletion region having the width of 6×10^{-6} m, will be _____ $\times 10^5$ N/C.

Answer (1)

Sol. $E = \frac{V}{d} = \frac{0.6}{6 \times 10^{-6}} = 1 \times 10^5$

CHEMISTRY

SECTION - A

Multiple Choice Questions: This section contains 20 multiple choice questions. Each question has 4 choices (1), (2), (3) and (4), out of which **ONLY ONE** is correct.

Choose the correct answer :

1. Which of the following pair of molecules contain odd electron molecule and an expanded octet molecule?

- (A) BCl_3 and SF_6 (B) NO and H_2SO_4
(C) SF_6 and H_2SO_4 (D) BCl_3 and NO

Answer (B)

Sol. NO is an odd electron species as N has 5 valence electrons and O has 6 valence electrons. Thus overall 1 electron on N remains unpaired.

S in H_2SO_4 has an expanded octet thus H_2SO_4 is expanded octet molecule.

2.
$$\text{N}_{2(g)} + 3\text{H}_{2(g)} \rightleftharpoons 2\text{NH}_{3(g)}$$

$$\begin{matrix} 20\text{ g} & 5\text{ g} & \end{matrix}$$

Consider the above reaction, the limiting reagent of the reaction and number of moles of NH_3 formed respectively are :

- (A) H_2 , 1.42 moles (B) H_2 , 0.71 moles
(C) N_2 , 1.42 moles (D) N_2 , 0.71 moles

Answer (C)

Sol.
$$\text{N}_{2(g)} + 3\text{H}_{2(g)} \rightleftharpoons 2\text{NH}_{3(g)}$$

$$\begin{matrix} 20\text{ g} & 5\text{ g} & \end{matrix}$$

Ideally 28 g N_2 reacts with 6 g H_2 limiting reagent is N_2

\therefore Amount of NH_3 formed on reacting 20 g N_2 is,

$$= \frac{34 \times 20}{28} = 24.28 \text{ g}$$

$$= 1.42 \text{ moles}$$

3. 100 mL of 5% (w/v) solution of NaCl in water was prepared in 250 mL beaker. Albumin from the egg was poured into NaCl solution and stirred well. This resulted in a/an :

- (A) Lyophilic sol (B) Lyophobic sol
(C) Emulsion (D) Precipitate

Answer (A)

Sol. Albumin from the egg was poured into 100 mL of 5% (w/v) NaCl solution in water. This would result in the formation of lyophilic sol. Albumin molecules get dispersed in water the colloidal particles of albumin are stabilised by hydrogen bond with water molecules.

4. The first ionization enthalpy of Na , Mg and Si , respectively, are : 496, 737 and 786 kJ mol^{-1} . The first ionization enthalpy (kJ mol^{-1}) of Al is:

- (A) 487 (B) 768
(C) 577 (D) 856

Answer (C)

Sol. The first ionisation enthalpy of Al would be more than that of (sodium) Na but less than that of (silicon) Si and (magnesium) Mg .

Thus first ionisation enthalpy of Al would be 577 kJ/mole .

5. In metallurgy the term "gangue" is used for :

- (A) Contamination of undesired earthy materials.
(B) Contamination of metals, other than desired metal.
(C) Minerals which are naturally occurring in pure form
(D) Magnetic impurities in an ore.

Answer (A)

Sol. The term "gangue" is used for earthy or undesired materials in ore.

6. The reaction of zinc with excess of aqueous alkali, evolves hydrogen gas and gives :

- (A) $\text{Zn}(\text{OH})_2$ (B) ZnO
(C) $[\text{Zn}(\text{OH})_4]^{2-}$ (D) $[\text{ZnO}_2]^{2-}$

Answer (D)

Sol. Reaction of zinc with excess of aqueous alkali evolving hydrogen gas is as

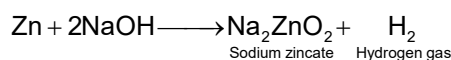

Thus along with H_2 it gives Na_2ZnO_2 or ZnO_2^{2-}

7. Lithium nitrate and sodium nitrate, when heated separately, respectively, give :

- (A) LiNO_2 and NaNO_2 (B) Li_2O and Na_2O
 (C) Li_2O and NaNO_2 (D) LiNO_2 and Na_2O

Answer (C)

Sol. Lithium nitrate when heated gives lithium oxide (Li_2O) whereas sodium nitrate on heating gives sodium nitrite

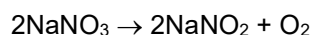

8. Number of lone pairs of electrons in the central atom of SCl_2 , O_3 , ClF_3 and SF_6 , respectively, are:

- (A) 0, 1, 2 and 2 (B) 2, 1, 2 and 0
 (C) 1, 2, 2 and 0 (D) 2, 1, 0 and 2

Answer (B)

Sol. The number of lone pair of electrons in the central atom of SCl_2 , O_3 , ClF_3 and SF_6 are 2, 1, 2 and 0 respectively

Their structures are as,

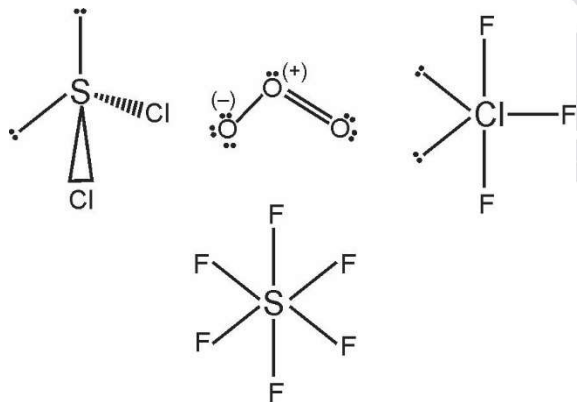

9. In following pairs, the one in which both transition metal ions are colourless is :

- (A) Sc^{3+} , Zn^{2+} (B) Ti^{4+} , Cu^{2+}
 (C) V^{2+} , Ti^{3+} (D) Zn^{2+} , Mn^{2+}

Answer (A)

Sol. Sc^{3+} and Zn^{2+} are colourless as they contain no unpaired electron. Whereas the transition metal ions Cu^{2+} , Ti^{3+} , V^{2+} and Mn^{2+} are coloured as they contain unpaired electrons.

The unpaired electron from lower energy d orbital gets excited to a higher energy d orbital on absorbing light of frequency which lies in visible region. The colour complementary to light absorbed is observed.

10. In neutral or faintly alkaline medium, KMnO_4 being a powerful oxidant can oxidize, thiosulphate almost quantitatively, to sulphate. In this reaction overall change in oxidation state of manganese will be

- (A) 5 (B) 1
 (C) 0 (D) 3

Answer (D)

Sol. In neutral or faintly alkaline medium, thiosulphate is oxidised almost quantitatively to sulphate ion according to reaction given below,

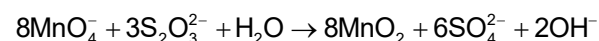

Here the Mn changes from Mn^{+7} to Mn^{+4}

Thus overall change in its oxidation number would be of 3.

11. Which among the following pairs has only herbicides?

- (A) Aldrin and Dieldrin
 (B) Sodium chlorate and Aldrin
 (C) Sodium arsenate and Dieldrin
 (D) Sodium chlorate and sodium arsenite

Answer (D)

Sol. Aldrin and Dieldrin are examples of pesticides whereas Sodium chlorate (NaClO_3) and Sodium arsenite (Na_3AsO_3) are examples of herbicides.

12. Which among the following is the strongest Bronsted base?

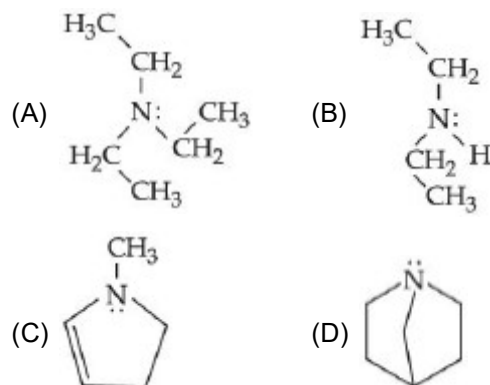

Answer (D)

Sol.  is the strongest base among the given

compounds due to the maximum +I effect and the lone pair of N is not in dynamic state so it can be donated easily.

13. Which among the following pairs of the structures will give different products on ozonolysis? (Consider the double bonds in the structures are rigid and not delocalized)

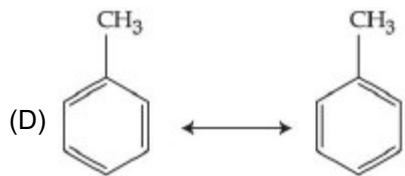
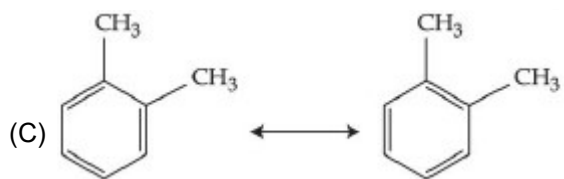
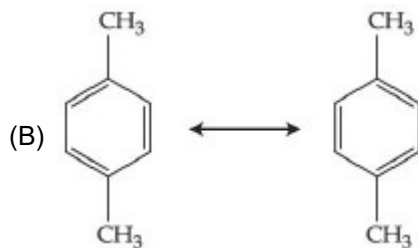
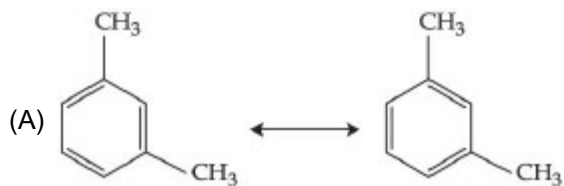

Answer (C)

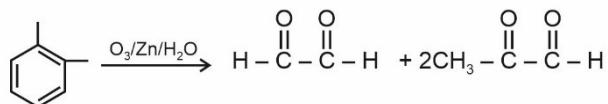
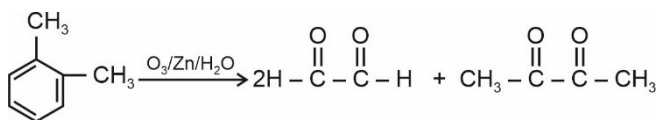

Sol.

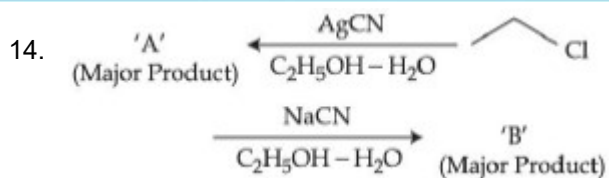

∴ in option (C) different products are produced.

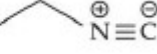
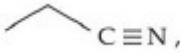
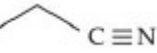
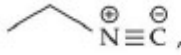
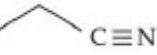

Considering the above reactions, the compound 'A' and compound 'B' respectively are :

- (A) , 
- (B) , 
- (C) , 
- (D) , 

Answer (C)

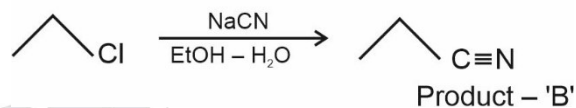
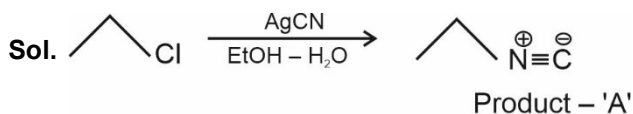

KCN is ionic so $\ominus\text{C}\equiv\text{N}$ attacks through 'C' - atom.

AgCN is covalent so CN attacks through 'N' - atom.

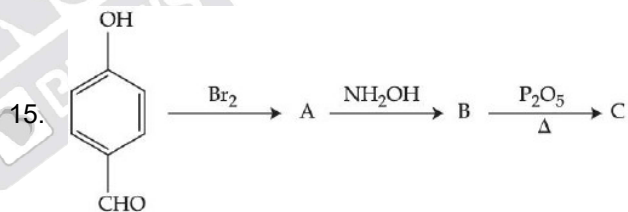

Consider the above reaction sequence, the product 'C' is

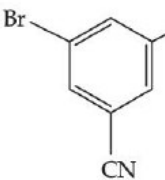
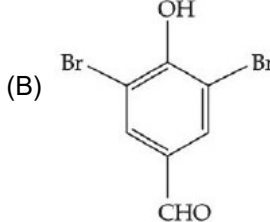
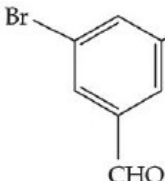
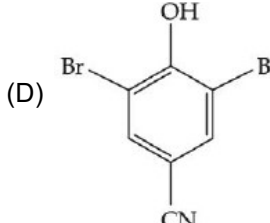
- (A) 
- (B) 
- (C) 
- (D) 

Answer (D)

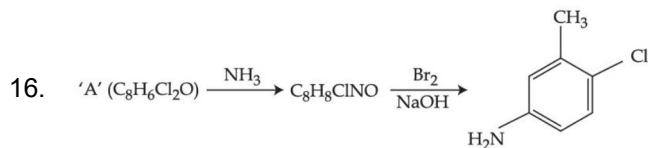
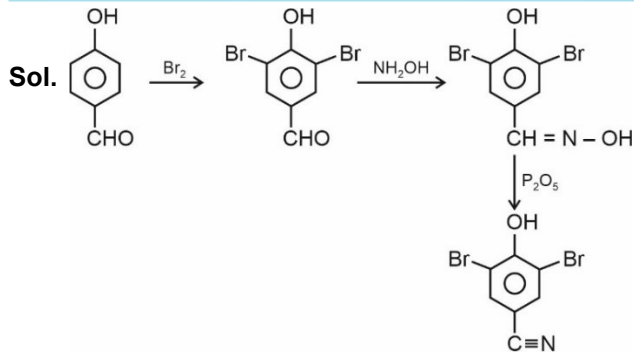

Consider the above reaction, the compound 'A' is :

- (A)
- (B)
- (C)
- (D)

Answer (C)

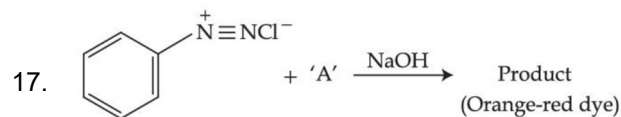
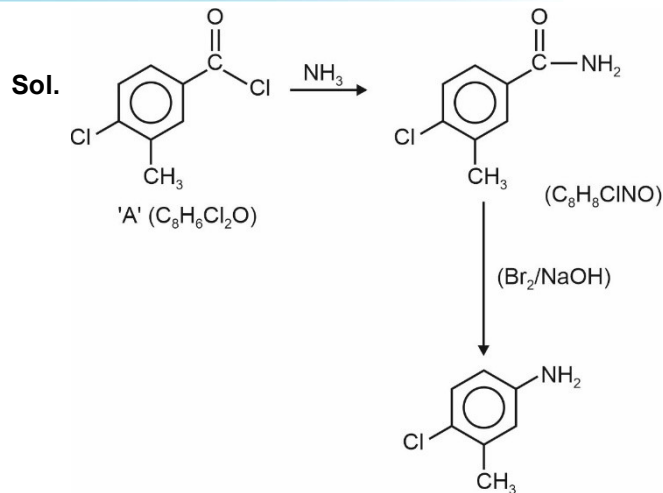

Which among the following represent reagent 'A'?

- (A)
- (B)
- (C)
- (D)

Answer (A)

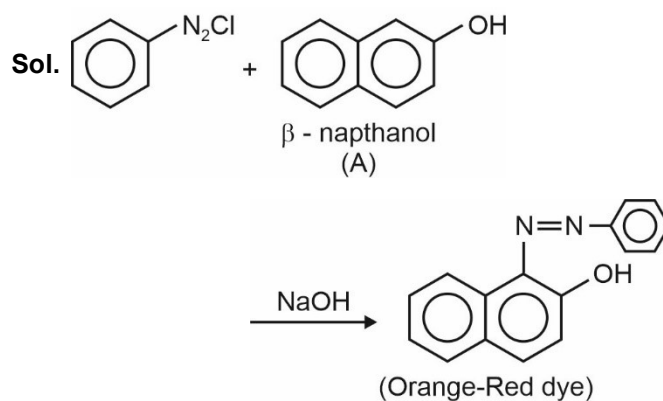

18. Consider the following reaction sequence :

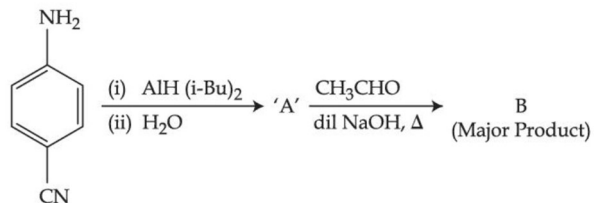

The product 'B' is :

- (A)
- (B)
- (C)
- (D)

Answer (B)

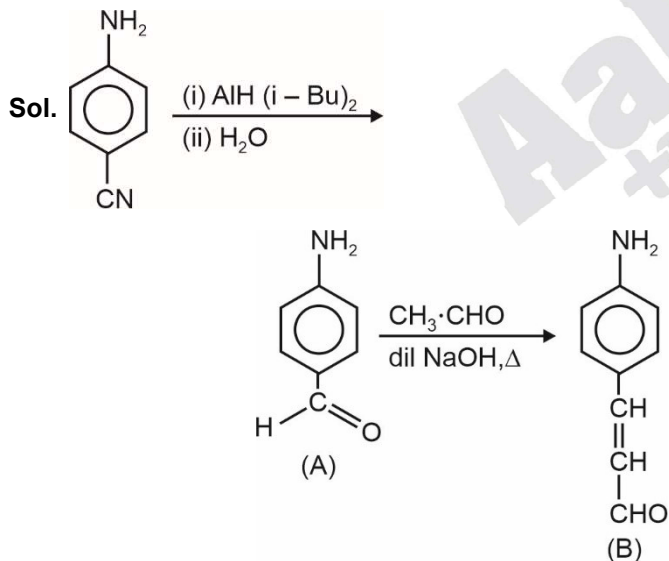

2nd reaction is the cross aldol reaction.

19. Which of the following compounds is an example of hypnotic drug?
- (A) Seldane (B) Amytal
(C) Aspartame (D) Prontosil

Answer (B)

Sol. Seldane → Antihistamine

Amytal → Barbiturate (Hypnotic)

Aspartame → Artificial sweetener

Prontosil → Antibiotics

20. A compound 'X' is acidic and it is soluble in NaOH solution, but insoluble in NaHCO₃ solution. Compound 'X' also gives violet colour with neutral FeCl₃ solution. The compound 'X' is :

- (A)
- (B)
- (C)
- (D)

Answer (B)

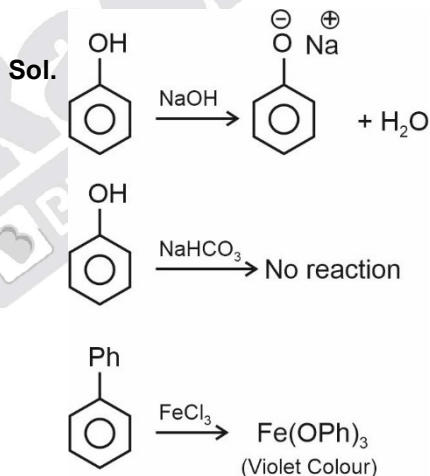

SECTION - B

Numerical Value Type Questions: This section contains 10 questions. In Section B, attempt any five questions out of 10. The answer to each question is a **NUMERICAL VALUE**. For each question, enter the correct numerical value (in decimal notation, truncated/rounded-off to the second decimal place; e.g. 06.25, 07.00, -00.33, -00.30, 30.27, -27.30) using the mouse and the on-screen virtual numeric keypad in the place designated to enter the answer.

1. Resistance of a conductivity cell (cell constant 129 m^{-1}) filled with 74.5 ppm solution of KCl is 100Ω (labelled as solution 1). When the same cell is filled with KCl solution of 149 ppm, the resistance is 50Ω (labelled as solution 2). The ratio of molar conductivity of solution 1 and solution 2 is $\frac{\Lambda_1}{\Lambda_2} = x \times 10^{-3}$. The value of x is _____. (Nearest integer)
(Given : molar mass of KCl is 74.5 g mol^{-1}).

Answer (1000)

Sol. Solution 1, $\Lambda_{m1} = \frac{1000 K}{M}$

$$M = \frac{74.5}{74.5} \times \frac{1000}{10^6} = 10^{-3} \text{ M}$$

[density of solution = 1 g/mol]

$$\Lambda_1 = \frac{1000 \times 129 \times 10^{-4}}{10^{-3}} = 129 \times 10^2 \text{ Scm}^2 \text{ mol}^{-1}$$

$$\left[K = \frac{x}{R} = \frac{129 \times 10^{-2}}{100} \right]$$

Solution 2,

$$K = \frac{129 \times 10^{-2}}{50}$$

$$\Lambda_2 = \frac{1000 \times 129 \times 10^{-2}}{50 \text{ M}}$$

$$M = \frac{149}{74.5} \times \frac{1000}{10^6} = 2 \times 10^{-3} \text{ M}$$

$$\Lambda_2 = \frac{1000 \times 129 \times 10^{-2}}{50 \times 2 \times 10^{-3}} = 129 \times 10^2 \text{ Scm}^2 \text{ mol}^{-1}$$

$$\frac{\Lambda_1}{\Lambda_2} = 1 = 1000 \times 10^{-3}$$

$$\Rightarrow x = 1000$$

2. Ionic radii of cation A^+ and anion B^- are 102 and 181 pm respectively. These ions are allowed to crystallize into an ionic solid. This crystal has cubic close packing for B^- . A^+ is present in all octahedral voids. The edge length of the unit cell of the crystal AB is _____pm. (Nearest integer)

Answer (566)

Sol. In cubic close packing, octahedral voids form at edge centers and body center of the cube

$$a = 2(r_{A^+} + r_{B^-})$$

$$a = 2(102 + 181)$$

$$a = 566 \text{ pm}$$

3. The minimum uncertainty in the speed of an electron in an one dimensional region of length $2a_0$ (Where a_0 = Bohr radius 52.9 pm) is _____ km s^{-1} .
(Given : Mass of electron = $9.1 \times 10^{-31} \text{ kg}$, Planck's constant $h = 6.63 \times 10^{-34} \text{ Js}$)

Answer (548)

Sol. $\Delta x \cdot \Delta v \geq \frac{h}{4\pi m}$

$$\Delta x = 2 \times 52.9 \times 10^{-12} \text{ m}$$

$$\Delta v \geq \frac{6.63 \times 10^{-34}}{4 \times 3.14 \times 9.1 \times 10^{-31} \times 2 \times 52.9 \times 10^{-12}}$$

$$\Delta v \geq 5.48 \times 10^{-4} \times 10^9 \text{ m/s}$$

$$\Delta v \geq 548 \text{ km/s (Rounded off to the nearest integer)}$$

4. When 600 mL of 0.2 M HNO_3 is mixed with 400 mL of 0.1 M NaOH solution in a flask, the rise in temperature of the flask is _____ $\times 10^{-2} \text{ }^\circ\text{C}$.
(Enthalpy of neutralisation = 57 kJ mol^{-1} and Specific heat of water = $4.2 \text{ JK}^{-1} \text{ g}^{-1}$)
(Neglect heat capacity of flask)

Answer (54)

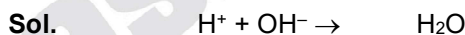

m moles	120	40	—
	80	—	40

Heat liberated from reaction

$$= 40 \times 10^{-3} \times 57 \times 10^3 \text{ J} \quad \dots(1)$$

Heat gained by solution = $m\Delta T$

$$m = \text{mass of solution} = V \times d = 1000 \times 1 = 1000 \text{ g}$$

$$\text{Heat gained by solution} = 1000 \times 4.2 \times \Delta T \quad \dots(2)$$

From (1) and (2)

Heat liberated = Heat gained

$$40 \times 10^{-3} \times 57 \times 10^3 = 1000 \times 4.2 \times \Delta T$$

$$\Delta T = 54 \times 10^{-2} \text{ }^\circ\text{C}$$

(Rounded off to the nearest integer)

5. If O_2 gas is bubbled through water at 303 K, the number of millimoles of O_2 gas that dissolve in 1 litre of water is _____. (Nearest integer)
(Given : Henry's Law constant for O_2 at 303 K is 46.82 k bar and partial pressure of $\text{O}_2 = 0.920 \text{ bar}$)
(Assume solubility of O_2 in water is too small, nearly negligible)

Answer (1)

Sol. From Henry's law,

$$X(\text{oxygen}) = \frac{p(\text{oxygen})}{K_H} = \frac{0.920}{46.82 \times 10^3} = 1.96 \times 10^{-5}$$

As 1 litre of water contains 55.5 mol of it, therefore,
→ n represents moles of O₂ in solution.

$$X(\text{oxygen}) = \frac{n}{n + 55.5} \approx \frac{n}{55.5} \quad (n \ll 55.5)$$

$$\frac{n}{55.5} = 1.96 \times 10^{-5}$$

$$n = 108.8 \times 10^{-5} = 1.08 \times 10^{-3} \text{ moles}$$

$$m \text{ moles of oxygen} = 1.08 \times 10^{-3} \times 10^3 = 1 \text{ m mole}$$

6. If the solubility product of PbS is 8×10^{-28} , then the solubility of PbS in pure water at 298 K is $x \times 10^{-16}$ mol L⁻¹. The value of x is _____. (Nearest integer)

$$[\text{Given} : \sqrt{2} = 1.41]$$

Answer (282)

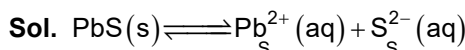

$$K_{sp} = S^2$$

$$8 \times 10^{-28} = S^2$$

$$S = 2\sqrt{2} \times 10^{-14} \text{ mol/L}$$

$$\Rightarrow 2.82 \times 10^{-14} \text{ mol/L} = 282 \times 10^{-16} \text{ mol/L}$$

Hence,

$$x = 282$$

7. The reaction between X and Y is first order with respect to X and zero order with respect to Y.

Experiment	$\frac{[X]}{\text{mol L}^{-1}}$	$\frac{[Y]}{\text{mol L}^{-1}}$	$\frac{\text{Initial rate}}{\text{mol L}^{-1} \text{ min}^{-1}}$
I	0.1	0.1	2×10^{-3}
II	L	0.2	4×10^{-3}
III	0.4	0.4	$M \times 10^{-3}$
IV	0.1	0.2	2×10^{-3}

Examine the data of table and calculate ratio of numerical values of M and L. (Nearest integer)

Answer (40)

Sol. Rate $\propto [X]^1[Y]^0$

$$\text{Rate} = k[X]$$

From Exp I and II,

$$\frac{4 \times 10^{-3}}{2 \times 10^{-3}} = \left(\frac{L}{0.1}\right)^1 \left(\frac{0.2}{0.1}\right)^0$$

$$2 = (10L)^1.$$

$$\text{Hence } L = 0.2 \text{ mol/L}$$

From Exp III and IV,

$$\frac{M \times 10^{-3}}{2 \times 10^{-3}} = \left(\frac{0.4}{0.1}\right) \left(\frac{0.4}{0.2}\right)^0$$

$$\frac{M}{2} = 4$$

$$M = 8$$

$$\frac{M}{L} = \frac{8}{0.2} = 40$$

8. In a linear tetrapeptide (constituted with different amino acids) – (number of peptide bonds) is _____.

Answer (1)

Sol. In a linear tetrapeptide, four amino acids are linked and three peptide bonds are present.

$$\text{Hence, } 4 - 3 = 1$$

9. In bromination of Propyne, with Bromine 1,1,2,2-tetrabromopropane is obtained in 27% yield. The amount of 1,1,2,2-tetrabromopropane obtained from 1 g of Bromine in this reaction is _____ $\times 10^{-1}$ g. (Nearest integer)

(Molar Mass : Bromine = 80 g/mol)

Answer (3)

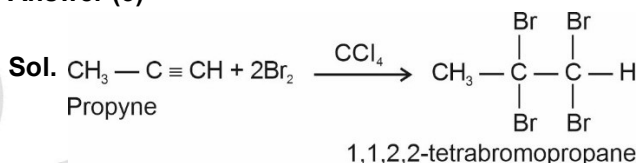

2 moles Br₂ \equiv 1 mole 1,1,2,2-tetrabromopropane

$$\frac{1}{160} \text{ mole Br}_2$$

$$\equiv \frac{1}{2} \times \frac{1}{160} \text{ mole 1,1,2,2-tetrabromopropane}$$

But yield of reaction is only 27%

Moles of 1,1,2,2-tetrabromopropane

$$= \frac{1}{2} \times \frac{1}{160} \times \frac{27}{100}$$

Molar mass of 1,1,2,2-tetrabromopropane = 360 g

Mass of 1,1,2,2-tetrabromopropane

$$= \frac{1}{2} \times \frac{1}{160} \times \frac{27}{100} \times 360 \text{ g}$$

$$\approx 3 \times 10^{-1} \text{ g}$$

10. [Fe(CN)⁶]³⁻ should be an inner orbital complex. Ignoring the pairing energy, the value of crystal field stabilization energy for this complex is (-) _____ Δ_0 . (Nearest integer)

Answer (2)

Sol. In [Fe(CN)⁶]³⁻, Fe is present in (+3) oxidation state Fe(III) \Rightarrow inner orbital complex $\Rightarrow d^5$ (with pairing)

$$\text{Configuration} \Rightarrow t_{2g}^5$$

$$\text{CFSE} = 5 \times \frac{-2}{5} \Delta_0 = -2\Delta_0$$

MATHEMATICS

SECTION - A

Multiple Choice Questions: This section contains 20 multiple choice questions. Each question has 4 choices (1), (2), (3) and (4), out of which **ONLY ONE** is correct.

Choose the correct answer :

1. Let R be a relation from the set $\{1, 2, 3, \dots, 60\}$ to itself such that $R = \{(a, b) : b = pq, \text{ where } p, q \geq 3 \text{ are prime numbers}\}$. Then, the number of elements in R is :
- (A) 600
(B) 660
(C) 540
(D) 720

Answer (B)

Sol. b can take its values as 9, 15, 21, 33, 39, 51, 57, 25, 35, 55, 49
 b can take these 11 values
and a can take any of 60 values
So, number of elements in $R = 60 \times 11 = 660$

2. If $z = 2 + 3i$, then $z^5 + (\bar{z})^5$ is equal to :
- (A) 244 (B) 224
(C) 245 (D) 265

Answer (A)

Sol. $z = (2 + 3i)$

$$\begin{aligned} \Rightarrow z^5 &= (2 + 3i)((2 + 3i)^2)^2 \\ &= (2 + 3i)(-5 + 12i)^2 \\ &= (2 + 3i)(-119 - 120i) \\ &= -238 - 240i - 357i + 360 \\ &= 122 - 597i \\ \bar{z}^5 &= 122 + 597i \\ z^5 + \bar{z}^5 &= 244 \end{aligned}$$

3. Let A and B be two 3×3 non-zero real matrices such that AB is a zero matrix. Then
- (A) the system of linear equations $AX = 0$ has a unique solution
(B) the system of linear equations $AX = 0$ has infinitely many solutions
(C) B is an invertible matrix
(D) $\text{adj}(A)$ is an invertible matrix

Answer (B)

Sol. AB is zero matrix

$$\begin{aligned} \Rightarrow |A| &= |B| = 0 \\ \text{So neither } A \text{ nor } B &\text{ is invertible} \\ \text{If } |A| &= 0 \\ \Rightarrow |\text{adj } A| &= 0 \text{ so adj } A \text{ is not invertible} \\ AX = 0 &\text{ is homogeneous system and } |A| = 0 \\ \text{So, it is having infinitely many solutions} \end{aligned}$$

4. If $\frac{1}{(20-a)(40-a)} + \frac{1}{(40-a)(60-a)} + \dots + \frac{1}{(180-a)(200-a)} = \frac{1}{256}$, then the maximum value of a is :
- (A) 198 (B) 202
(C) 212 (D) 218

Answer (C)

$$\begin{aligned} \text{Sol. } \frac{1}{20} \left(\frac{1}{20-a} - \frac{1}{40-a} + \frac{1}{40-a} - \frac{1}{60-a} + \dots + \frac{1}{180-a} - \frac{1}{200-a} \right) &= \frac{1}{256} \\ \Rightarrow \frac{1}{20} \left(\frac{1}{20-a} - \frac{1}{200-a} \right) &= \frac{1}{256} \\ \Rightarrow \frac{1}{20} \left(\frac{180}{(20-a)(200-a)} \right) &= \frac{1}{256} \\ \Rightarrow (20-a)(200-a) &= 9.256 \\ \text{OR } a^2 - 220a + 1696 &= 0 \\ \Rightarrow a &= 212, 8 \end{aligned}$$

5. If $\lim_{x \rightarrow 0} \frac{\alpha e^x + \beta e^{-x} + \gamma \sin x}{x \sin^2 x} = \frac{2}{3}$, where $\alpha, \beta, \gamma \in \mathbf{R}$, then which of the following is **NOT** correct?
- (A) $\alpha^2 + \beta^2 + \gamma^2 = 6$ (B) $\alpha\beta + \beta\gamma + \gamma\alpha + 1 = 0$
(C) $\alpha\beta^2 + \beta\gamma^2 + \gamma\alpha^2 + 3 = 0$ (D) $\alpha^2 - \beta^2 + \gamma^2 = 4$

Answer (C)

Sol. $\lim_{x \rightarrow 0} \frac{\alpha e^x + \beta e^{-x} + \gamma \sin x}{x \sin^2 x} = \frac{2}{3}$

$\Rightarrow \alpha + \beta = 0$ (to make indeterminate form) ... (i)

Now,

$\lim_{x \rightarrow 0} \frac{\alpha e^x - \beta e^{-x} + \gamma \cos x}{3x^2} = \frac{2}{3}$ (Using L-H Rule)

$\Rightarrow \alpha - \beta + \gamma = 0$ (to make indeterminate form) ... (ii)

Now,

$\lim_{x \rightarrow 0} \frac{\alpha e^x + \beta e^{-x} - \gamma \sin x}{6x} = \frac{2}{3}$ (Using L-H Rule)

$\Rightarrow \frac{\alpha - \beta - \gamma}{6} = \frac{2}{3}$

$\Rightarrow \alpha - \beta - \gamma = 4$... (iii)

$\Rightarrow \gamma = -2$

and (i) + (ii)

$2\alpha = -\gamma$

$\Rightarrow \alpha = 1$ and $\beta = -1$

and $\alpha\beta^2 + \beta\gamma^2 + \gamma\alpha^2 + 3 = 1 - 4 - 2 + 3 = -2$

6. The integral $\int_0^{\frac{\pi}{2}} \frac{1}{3 + 2 \sin x + \cos x} dx$ is equal to

(A) $\tan^{-1}(2)$ (B) $\tan^{-1}(2) - \frac{\pi}{4}$

(C) $\frac{1}{2} \tan^{-1}(2) - \frac{\pi}{8}$ (D) $\frac{1}{2}$

Answer (B)

Sol. $I = \int_0^{\pi/2} \frac{1}{3 + 2 \sin x + \cos x} dx$

$= \int_0^{\pi/2} \frac{(1 + \tan^2 x/2) dx}{3(1 + \tan^2 x/2) + 2(2 \tan x/2) + (1 - \tan^2 x/2)}$

Let $\tan x/2 = t \Rightarrow \sec^2 x/2 dx = 2dt$

$I = \int_0^1 \frac{2dt}{4 + 2t^2 + 4t}$

$= \int_0^1 \frac{dt}{t^2 + 2t + 2} = \int_0^1 \frac{dt}{(t+1)^2 + 1}$

$= \tan^{-1}(t+1) \Big|_0^1 = \tan^{-1} 2 - \frac{\pi}{4}$

7. Let the solution curve $y = y(x)$ of the differential equation $(1 + e^{2x}) \left(\frac{dy}{dx} + y \right) = 1$ pass through the point $\left(0, \frac{\pi}{2} \right)$. Then, $\lim_{x \rightarrow \infty} e^x y(x)$ is equal to

(A) $\frac{\pi}{4}$ (B) $\frac{3\pi}{4}$

(C) $\frac{\pi}{2}$ (D) $\frac{3\pi}{2}$

Answer (B)

Sol. D.E. $(1 + e^{2x}) \left(\frac{dy}{dx} + y \right) = 1$

$\Rightarrow \frac{dy}{dx} + y = \frac{1}{1 + e^{2x}}$

I.F. = $e^{\int 1 \cdot dx} = e^x$

\therefore Solution

$e^x y(x) = \int \frac{e^x}{1 + e^{2x}} dx$

$\Rightarrow e^x y(x) = \tan^{-1}(e^x) + C$

\therefore It passes through $\left(0, \frac{\pi}{2} \right)$, $C = \frac{\pi}{2} - \frac{\pi}{4} = \frac{\pi}{4}$

$\therefore \lim_{x \rightarrow \infty} e^x y(x) = \lim_{x \rightarrow \infty} \tan^{-1}(e^x) + \frac{\pi}{4}$

$= \frac{3\pi}{4}$

8. Let a line L pass through the point intersection of the lines $bx + 10y - 8 = 0$ and $2x - 3y = 0$, $b \in \mathbf{R} - \left\{ \frac{4}{3} \right\}$. If the line L also passes through the point $(1, 1)$ and touches the circle $17(x^2 + y^2) = 16$, then the eccentricity of the ellipse $\frac{x^2}{5} + \frac{y^2}{5} = 1$ is

(A) $\frac{2}{\sqrt{5}}$ (B) $\sqrt{\frac{3}{5}}$

(C) $\frac{1}{\sqrt{5}}$ (D) $\sqrt{\frac{2}{5}}$

Answer (B)

Sol. $L_1 : bx + 10y - 8 = 0$, $L_2 : 2x - 3y = 0$

then $L : (bx + 10y - 8) + \lambda(2x - 3y) = 0$

\therefore It passes through $(1, 1)$

$\therefore b + 2 - \lambda = 0 \Rightarrow \lambda = b + 2$

and touches the circle $x^2 + y^2 = \frac{16}{17}$

$$\left| \frac{8^2}{(2\lambda + b)^2 + (10 - 3\lambda)^2} \right| = \frac{16}{17}$$

$$\Rightarrow 4\lambda^2 + b^2 + 4b\lambda + 100 + 9\lambda^2 - 60\lambda = 68$$

$$\Rightarrow 13(b+2)^2 + b^2 + 4b(b+2) - 60(b+2) + 32 = 0$$

$$\Rightarrow 18b^2 = 36 \therefore b^2 = 2$$

\therefore Eccentricity of ellipse : $\frac{x^2}{5} + \frac{y^2}{b^2} = 1$ is

$$\therefore e = \sqrt{1 - \frac{2}{5}} = \sqrt{\frac{3}{5}}$$

9. If the foot of the perpendicular from the point $A(-1, 4, 3)$ on the plane $P : 2x + my + nz = 4$, is $\left(-2, \frac{7}{2}, \frac{3}{2}\right)$, then the distance of the point A from the plane P , measured parallel to a line with direction ratios $3, -1, -4$, is equal to

- (A) 1 (B) $\sqrt{26}$
(C) $2\sqrt{2}$ (D) $\sqrt{14}$

Answer (B)

Sol. $\left(-2, \frac{7}{2}, \frac{3}{2}\right)$ satisfies the plane $P : 2x + my + nz = 4$

$$-4 + \frac{7m}{2} + \frac{3n}{2} = 4 \Rightarrow 7m + 3n = 16 \quad (i)$$

Line joining $A(-1, 4, 3)$ and $\left(-2, \frac{7}{2}, \frac{3}{2}\right)$ is perpendicular to $P : 2x + my + nz = 4$

$$\frac{1}{2} = \frac{3}{m} = \frac{3}{n} \Rightarrow m = 1 \text{ \& } n = 3$$

Plane $P : 2x + y + 3z = 4$

Distance of P from $A(-1, 4, 3)$ parallel to the line

$$\frac{x+1}{3} = \frac{y-4}{-1} = \frac{z-3}{-4} : L$$

for point of intersection of P & L

$$2(3r-1) + (-r+4) + 3(-4r+3) = 4 \Rightarrow r = 1$$

Point of intersection : $(2, 3, -1)$

$$\begin{aligned} \text{Required distance} &= \sqrt{3^2 + 1^2 + 4^2} \\ &= \sqrt{26} \end{aligned}$$

10. Let $\vec{a} = 3\hat{i} + \hat{j}$ and $\vec{b} = \hat{i} + 2\hat{j} + \hat{k}$. Let \vec{c} be a vector satisfying $\vec{a} \times (\vec{b} \times \vec{c}) = \vec{b} + \lambda\vec{c}$. If \vec{b} and \vec{c} are non-parallel, then the value of λ is
- (A) -5 (B) 5
(C) 1 (D) -1

Answer (A)

Sol. $\vec{a} = 3\hat{i} + \hat{j}$ & $\vec{b} = \hat{i} + 2\hat{j} + \hat{k}$

$$\vec{a} \times (\vec{b} \times \vec{c}) = (\vec{a} \cdot \vec{c})\vec{b} - (\vec{a} \cdot \vec{b})\vec{c} = \vec{b} + \lambda\vec{c}$$

If \vec{b} & \vec{c} are non-parallel

$$\text{then } \vec{a} \cdot \vec{c} = 1 \text{ \& } \vec{a} \cdot \vec{b} = -\lambda$$

$$\text{but } \vec{a} \cdot \vec{b} = 5 \Rightarrow \lambda = -5$$

11. The angle of elevation of the top of a tower from a point A due north of it is α and from a point B at a distance of 9 units due west of A is $\cos^{-1}\left(\frac{3}{\sqrt{13}}\right)$. If the distance of the point B from the tower is 15 units, then $\cot \alpha$ is equal to :

- (A) $\frac{6}{5}$ (B) $\frac{9}{5}$
(C) $\frac{4}{3}$ (D) $\frac{7}{3}$

Answer (A)

Sol.

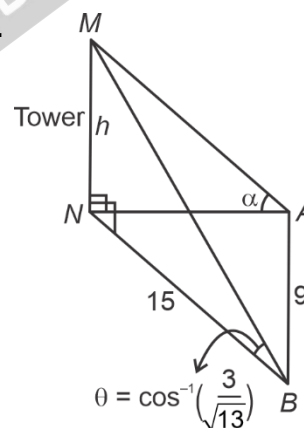

$$NA = \sqrt{15^2 - 9^2} = 12$$

$$\frac{h}{15} = \tan \theta = \frac{2}{3}$$

$$h = 10 \text{ units}$$

$$\cot \alpha = \frac{12}{10} = \frac{6}{5}$$

12. The statement $(p \wedge q) \Rightarrow (p \wedge r)$ is equivalent to :

- (A) $q \Rightarrow (p \wedge r)$ (B) $p \Rightarrow (p \wedge r)$
 (C) $(p \wedge r) \Rightarrow (p \wedge q)$ (D) $(p \wedge q) \Rightarrow r$

Answer (D)

Sol.

		A		B						
p	q	r	$p \wedge q$	$p \wedge r$	$A \rightarrow B$	$q \rightarrow B$	$p \rightarrow B$	$B \rightarrow A$	$A \rightarrow r$	
T	T	T	T	T	T	T	T	T	T	
T	F	T	F	T	T	T	T	F	T	
F	T	T	F	F	T	F	T	T	T	
F	F	T	F	F	T	T	T	T	T	
T	T	F	T	F	F	F	F	T	F	
T	F	F	F	F	T	T	F	T	T	
F	T	F	F	F	T	F	T	T	T	
F	F	F	F	F	T	T	T	T	T	

$(p \wedge q) \Rightarrow (p \wedge r)$ is equivalent to $(p \wedge q) \Rightarrow r$

13. Let the circumcentre of a triangle with vertices $A(a, 3)$, $B(b, 5)$ and $C(a, b)$, $ab > 0$ be $P(1, 1)$. If the line AP intersects the line BC at the point $Q(k_1, k_2)$, then $k_1 + k_2$ is equal to :

- (A) 2 (B) $\frac{4}{7}$
 (C) $\frac{2}{7}$ (D) 4

Answer (B)

Sol.

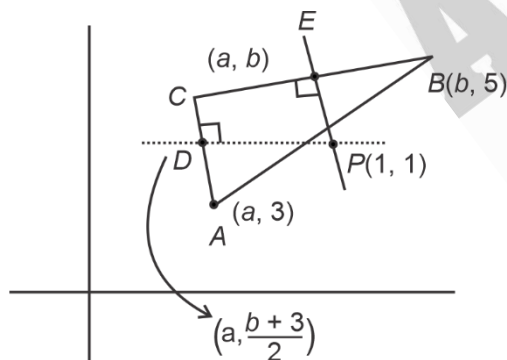

Let D be mid-point of AC , then

$$\frac{b+3}{2} = 1 \Rightarrow b = -1$$

Let E be mid-point of BC ,

$$\frac{5-b}{b-a} \cdot \frac{(3+b)}{2} = -1$$

On Putting $b = -1$, we get $a = 5$ or -3

But $a = 5$ is rejected as $ab > 0$

$A(-3, 3)$, $B(-1, 5)$, $C(-3, -1)$, $P(1, 1)$

Line $BC \Rightarrow y = 3x + 8$

Line $AP \Rightarrow y = \frac{3-x}{2}$

Point of intersection $\left(\frac{-13}{7}, \frac{17}{7}\right)$

14. Let \hat{a} and \hat{b} be two unit vectors such that the angle between them is $\frac{\pi}{4}$. If θ is the angle between the

vectors $(\hat{a} + \hat{b})$ and $(\hat{a} + 2\hat{b} + 2(\hat{a} \times \hat{b}))$, then the value of $164 \cos^2 \theta$ is equal to :

- (A) $90 + 27\sqrt{2}$
 (B) $45 + 18\sqrt{2}$
 (C) $90 + 3\sqrt{2}$
 (D) $54 + 90\sqrt{2}$

Answer (A)

Sol. $\hat{a} \cdot \hat{b} = \frac{1}{\sqrt{2}}$ and $|\hat{a} \times \hat{b}| = \frac{1}{\sqrt{2}}$

$$\frac{(\hat{a} + \hat{b}) \cdot (\hat{a} + 2\hat{b} + 2(\hat{a} \times \hat{b}))}{|\hat{a} + \hat{b}| |\hat{a} + 2\hat{b} + 2(\hat{a} \times \hat{b})|} = \cos \theta$$

$$\Rightarrow \cos \theta = \frac{1 + 3\hat{a}\hat{b} + 2}{|\hat{a} + \hat{b}| |\hat{a} + 2\hat{b} + 2(\hat{a} \times \hat{b})|}$$

$$|\hat{a} + \hat{b}|^2 = 2 + \sqrt{2}$$

$$|\hat{a} + 2\hat{b} + 2(\hat{a} \times \hat{b})|^2 = 1 + 4 + 4|\hat{a} \times \hat{b}|^2 + 4\hat{a}\hat{b} = 5 + 4 \cdot \frac{1}{2} + \frac{4}{\sqrt{2}} = 7 + 2\sqrt{2}$$

$$\text{So, } \cos^2 \theta = \frac{\left(3 + \frac{3}{\sqrt{2}}\right)^2}{(2 + \sqrt{2})(7 + 2\sqrt{2})} = \frac{9\sqrt{2}(5\sqrt{2} + 3)}{164}$$

$$\Rightarrow 164 \cos^2 \theta = 90 + 27\sqrt{2}$$

15. If $f(\alpha) = \int_1^\alpha \frac{\log_{10} t}{1+t} dt$, $\alpha > 0$, then $f(e^3) + f(e^{-3})$ is equal to :

- (A) 9 (B) $\frac{9}{2}$
 (C) $\frac{9}{\log_e(10)}$ (D) $\frac{9}{2\log_e(10)}$

Answer (D)

Sol. $f(\alpha) = \int_1^\alpha \frac{\log_{10} t}{1+t} dt \quad \dots(i)$

$$f\left(\frac{1}{\alpha}\right) = \int_1^{\frac{1}{\alpha}} \frac{\log_{10} t}{1+t} dt$$

Substituting $t \rightarrow \frac{1}{p}$

$$\begin{aligned} f\left(\frac{1}{\alpha}\right) &= \int_1^\alpha \frac{\log_{10}\left(\frac{1}{p}\right)}{1+\frac{1}{p}} \left(\frac{-1}{p^2}\right) dp \\ &= \int_1^\alpha \frac{\log_{10} p}{p(p+1)} dp = \int_1^\alpha \left(\frac{\log_{10} t}{t} - \frac{\log_{10} t}{t+1}\right) dt \end{aligned}$$

... (ii)

By (i) + (ii)

$$\begin{aligned} f(\alpha) + f\left(\frac{1}{\alpha}\right) &= \int_1^\alpha \frac{\log_{10} t}{t} dt = \int_1^\alpha \frac{\ln t}{t} \cdot \log_{10} e dt \\ &= \frac{(\ln \alpha)^2}{2 \log_e 10} \end{aligned}$$

$$\alpha = e^3 \Rightarrow f(e^3) + f(e^{-3}) = \frac{9}{2 \log_e 10}$$

16. The area of the region $\{(x, y); |x-1| \leq y \leq \sqrt{5-x^2}\}$

is equal to

(A) $\frac{5}{2} \sin^{-1}\left(\frac{3}{5}\right) - \frac{1}{2}$ (B) $\frac{5\pi}{4} - \frac{3}{2}$

(C) $\frac{3\pi}{4} + \frac{3}{2}$ (D) $\frac{5\pi}{4} - \frac{1}{2}$

Answer (D)

Sol. $A = \int_{-1}^1 (\sqrt{5-x^2} - (1-x)) dx$

$$+ \int_1^2 (\sqrt{5-x^2} - (x-1)) dx$$

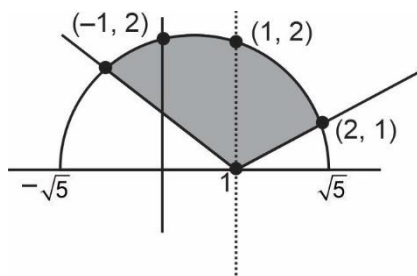

$$\begin{aligned} A &= 2 \left(\frac{x}{2} \sqrt{5-x^2} + \frac{5}{2} \sin^{-1} \frac{x}{\sqrt{5}} \right) - 2x \Big|_0^1 \\ &\quad + \frac{x}{2} \sqrt{5-x^2} + \frac{5}{2} \sin^{-1} \frac{x}{\sqrt{5}} - \frac{x^2}{2} + x \Big|_1^2 \\ &= \left(\frac{5\pi}{4} - \frac{1}{2} \right) \text{ sq. units} \end{aligned}$$

17. Let the focal chord of the parabola $P: y^2 = 4x$ along the line $L: y = mx + c, m > 0$ meet the parabola at the points M and N . Let the line L be a tangent to the hyperbola $H: x^2 - y^2 = 4$. If O is the vertex of P and F is the focus of H on the positive x -axis, then the area of the quadrilateral $OMFN$ is

(A) $2\sqrt{6}$

(B) $2\sqrt{14}$

(C) $4\sqrt{6}$

(D) $4\sqrt{14}$

Answer (B)

Sol. $H: \frac{x^2}{4} - \frac{y^2}{4} = 1$

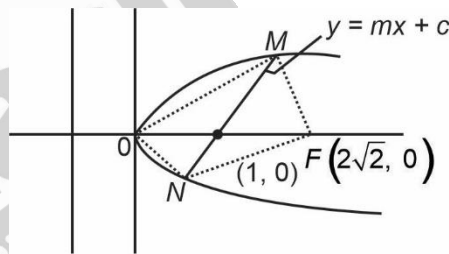

Focus $(ae, 0)$

$$F(2\sqrt{2}, 0)$$

$y = mx + c$ passes through $(1, 0)$

$$0 = m + c \quad \dots(i)$$

L is tangent to hyperbola

$$C = \pm \sqrt{4m^2 - 4}$$

$$-m = \pm \sqrt{4m^2 - 4}$$

$$m^2 = 4m^2 - 4$$

$$m = \frac{2}{\sqrt{3}}$$

$$C = \frac{-2}{\sqrt{3}}$$

$$T: y = \frac{2}{\sqrt{3}}x - \frac{2}{\sqrt{3}}$$

$$P: y^2 = 4x$$

$$y^2 = 4 \left(\frac{\sqrt{3}y + 2}{2} \right)$$

$$y^2 - 2\sqrt{3}y - 4 = 0$$

Area

$$\frac{1}{2} \begin{vmatrix} 0 & 0 \\ x_1 & y_1 \\ 2\sqrt{2} & 0 \\ x_2 & y_2 \\ 0 & 0 \end{vmatrix}$$

$$= \left| \frac{1}{2} (-2\sqrt{2}y_1 + 2\sqrt{2}y_2) \right|$$

$$= \sqrt{2} |y_2 - y_1| = \sqrt{2} \sqrt{(y_1 + y_2)^2 - 4y_1y_2}$$

$$= \sqrt{56}$$

$$= 2\sqrt{14}$$

18. The number of points, where the function $f: \mathbb{R} \rightarrow \mathbb{R}$,

$$f(x) = |x - 1| \cos|x - 2| \sin|x - 1| + (x - 3)|x^2 - 5x + 4|, \text{ is NOT differentiable, is}$$

- (A) 1 (B) 2
(C) 3 (D) 4

Answer (B)

Sol. $f: \mathbb{R} \rightarrow \mathbb{R}$.

$$\begin{aligned} f(x) &= |x - 1| \cos|x - 2| \sin|x - 1| + (x - 3)|x^2 - 5x + 4| \\ &= |x - 1| \cos|x - 2| \sin|x - 1| + (x - 3)|x - 1||x - 4| \\ &= |x - 1| [\cos|x - 2| \sin|x - 1| + (x - 3)|x - 4|] \end{aligned}$$

Sharp edges at $x = 1$ and $x = 4$

\therefore Non-differentiable at $x = 1$ and $x = 4$

19. Let $S = \{1, 2, 3, \dots, 2022\}$. Then the probability, that a randomly chosen number n from the set S such that $\text{HCF}(n, 2022) = 1$, is

- (A) $\frac{128}{1011}$ (B) $\frac{166}{1011}$
(C) $\frac{127}{337}$ (D) $\frac{112}{337}$

Answer (D)

Sol. $S = \{1, 2, 3, \dots, 2022\}$

$$\text{HCF}(n, 2022) = 1$$

$\Rightarrow n$ and 2022 have no common factor

Total elements = 2022

$$2022 = 2 \times 3 \times 337$$

M : numbers divisible by 2.

$$\{2, 4, 6, \dots, 2022\} \quad n(M) = 1011$$

N : numbers divisible by 3.

$$\{3, 6, 9, \dots, 2022\} \quad n(N) = 674$$

L : numbers divisible by 6.

$$\{6, 12, 18, \dots, 2022\} \quad n(L) = 337$$

$$n(M \cup N) = n(M) + n(N) - n(L)$$

$$= 1011 + 674 - 337$$

$$= 1348$$

O = Number divisible by 337 but not in $M \cup N$

$$\{337, 1685\}$$

Number divisible by 2, 3 or 337

$$= 1348 + 2 = 1350$$

$$\text{Required probability} = \frac{2022 - 1350}{2022}$$

$$= \frac{672}{2022}$$

$$= \frac{112}{337}$$

20. Let $f(x) = 3^{(x^2-2)^3+4}, x \in \mathbb{R}$. Then which of the following statements are true?

P : $x = 0$ is a point of local minima of f

Q : $x = \sqrt{2}$ is a point of inflection of f

R : f' is increasing for $x > \sqrt{2}$

- (A) Only P and Q (B) Only P and R
(C) Only Q and R (D) All P, Q and R

Answer (D)

Sol. $f(x) = 3^{(x^2-2)^3+4}, x \in \mathbb{R}$

$$f(x) = 81.3^{(x^2-2)^3}$$

$$f'(x) = 81.3^{(x^2-2)^3} \ln 2.3(x^2-2)2x$$

$$= (486 \ln 2) \left(3^{(x^2-2)^3} (x^2-2)x \right)$$

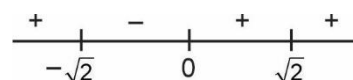

⇒ $x = 0$ is the local minima.

$$f'(x) = (486 \ln 2) \left(\begin{array}{l} 3(x^2-2)^3 \cdot (x^2-2) \\ (5x^2-2+6x^2 \ln 3(x^2-2)) \end{array} \right)$$

$$f''(x) = 0 \quad x = \sqrt{2}$$

$$f''(\sqrt{2}^+) > 0$$

$$f''(\sqrt{2}^-) < 0$$

⇒ $x = \sqrt{2}$ is point of inflection

$$f''(x) > 0 \quad \forall x > \sqrt{2}$$

⇒ $f(x)$ is increasing for $x > \sqrt{2}$

SECTION - B

Numerical Value Type Questions: This section contains 10 questions. In Section B, attempt any five questions out of 10. The answer to each question is a **NUMERICAL VALUE**. For each question, enter the correct numerical value (in decimal notation, truncated/rounded-off to the second decimal place; e.g. 06.25, 07.00, -00.33, -00.30, 30.27, -27.30) using the mouse and the on-screen virtual numeric keypad in the place designated to enter the answer.

1. Let $S = \{\theta \in (0, 2\pi) : 7 \cos^2\theta - 3 \sin^2\theta - 2 \cos^2 2\theta = 2\}$. Then, the sum of roots of all the equations $x^2 - 2(\tan^2\theta + \cot^2\theta)x + 6 \sin^2\theta = 0$, $\theta \in S$, is _____.

Answer (16)

Sol. $7 \cos^2\theta - 3 \sin^2\theta - 2 \cos^2 2\theta = 2$

$$\Rightarrow 4 \left(\frac{1 + \cos 2\theta}{2} \right) + 3 \cos 2\theta - 2 \cos^2 2\theta = 2$$

$$\Rightarrow 2 + 5 \cos^2\theta - 2 \cos^2 2\theta = 2$$

$$\Rightarrow \cos 2\theta = 0 \text{ or } \frac{5}{2} \text{ (rejected)}$$

$$\Rightarrow \cos 2\theta = 0 = \frac{1 - \tan^2\theta}{1 + \tan^2\theta} \Rightarrow \tan^2\theta = 1$$

$$\therefore \text{Sum of roots} = 2(\tan^2\theta + \cot^2\theta) = 2 \times 2 = 4$$

But as $\tan\theta = \pm 1$ for $\frac{\pi}{4}, \frac{3\pi}{4}, \frac{5\pi}{4}, \frac{7\pi}{4}$ in the interval $(0, 2\pi)$

∴ Four equations will be formed

Hence sum of roots of all the equations

$$= 4 \times 4 = 16.$$

2. Let the mean and the variance of 20 observations x_1, x_2, \dots, x_{20} be 15 and 9, respectively. For $a \in \mathbf{R}$, if the mean of $(x_1 + a)^2, (x_2 + a)^2, \dots, (x_{20} + a)^2$ is 178, then the square of the maximum value of a is equal to _____.

Answer (4)

Sol. Given $\sum_{i=1}^{20} x_i = 15 \Rightarrow \sum_{i=1}^{20} x_i = 300 \dots(1)$

and $\sum_{i=1}^{20} x_i^2 - (\bar{x})^2 = 9 \Rightarrow \sum_{i=1}^{20} x_i^2 = 4680 \dots(2)$

$$\text{Mean} = \frac{(x_1 + a)^2 + (x_2 + a)^2 + \dots + (x_{20} + a)^2}{20}$$

$$= 178$$

$$\Rightarrow \frac{\sum_{i=1}^{20} x_i^2 + 2a \sum_{i=1}^{20} x_i + 20a^2}{20} = 178$$

$$\Rightarrow 4680 + 600a + 20a^2 = 3560$$

$$\Rightarrow a^2 + 30a + 56 = 0$$

$$\Rightarrow a^2 + 28a + 2a + 56 = 0$$

$$\Rightarrow (a + 28)(a + 2) = 0$$

$$a_{\max} = -2 \Rightarrow a_{\max}^2 = 4.$$

3. Let a line with direction ratios $a, -4a, -7$ be perpendicular to the lines with direction ratios $3, -1, 2b$ and $b, a, -2$. If the point of intersection of the line $\frac{x+1}{a^2+b^2} = \frac{y-2}{a^2-b^2} = \frac{z}{1}$ and the plane $x - y + z = 0$ is (α, β, γ) , then $\alpha + \beta + \gamma$ is equal to _____.

Answer (10)

Sol. Given $a \cdot 3 + (-4a)(-1) + (-7) \cdot 2b = 0 \dots(1)$

and $ab - 4a^2 + 14 = 0 \dots(2)$

$$\Rightarrow a^2 = 4 \text{ and } b^2 = 1$$

$$\therefore \text{Line } L \equiv \frac{x+1}{5} = \frac{y-2}{3} = \frac{z}{1} = \lambda \text{ (say)}$$

$$\Rightarrow \text{General point on line is } (5\lambda - 1, 3\lambda + 2, \lambda)$$

for finding point of intersection with $x - y + z = 0$

$$\text{we get } (5\lambda - 1) - (3\lambda + 2) + \lambda = 0$$

$$\Rightarrow 3\lambda - 3 = 0 \Rightarrow \lambda = 1$$

$$\therefore \text{Point at intersection } (4, 5, 1)$$

$$\therefore \alpha + \beta + \gamma = 4 + 5 + 1 = 10$$

4. Let a_1, a_2, a_3, \dots be an A.P. If $\sum_{r=1}^{\infty} \frac{a_r}{2^r} = 4$, then $4a_2$ is equal to _____.

Answer (16)

Sol. Given

$$S = \frac{a_1}{2} + \frac{a_2}{2^2} + \frac{a_3}{2^3} + \frac{a_4}{2^4} + \dots \infty$$

$$\frac{1}{2}S = \frac{a_1}{2^2} + \frac{a_2}{2^3} + \dots \infty$$

$$\frac{S}{2} = \frac{a_1}{2} + \frac{(a_2 + a_1)}{2^2} + \frac{(a_3 + a_2)}{2^3} + \dots \infty$$

$$\Rightarrow \frac{S}{2} = \frac{a_1}{2} + \frac{d}{2}$$

$$\Rightarrow a_1 + d = a_2 = 4 \Rightarrow 4a_2 = 16$$

5. Let the ratio of the fifth term from the beginning to the fifth term from the end in the binomial expansion

of $\left(\sqrt[4]{2} + \frac{1}{\sqrt[4]{3}}\right)^n$, in the increasing powers of $\frac{1}{\sqrt[4]{3}}$ be

$\sqrt[4]{6} : 1$. If the sixth term from the beginning is $\frac{\alpha}{\sqrt[4]{3}}$,

then α is equal to _____.

Answer (84)

Sol. Fifth term from beginning = ${}^nC_4 \left(\frac{1}{2^4}\right)^{n-4} \left(\frac{-1}{3^4}\right)^4$

Fifth term from end = $(n - 5 + 1)^{\text{th}}$ term from begin

$$= {}^nC_{n-4} \left(\frac{1}{2^4}\right)^3 \left(\frac{-1}{3^4}\right)^{n-4}$$

$$\text{Given } \frac{{}^nC_4 2^{\frac{n-4}{4}} \cdot 3^{-1}}{{}^nC_{n-3} 2^4 \cdot 3^{-\left(\frac{n-4}{4}\right)}} = 6^4$$

$$\Rightarrow 6^{\frac{n-8}{4}} = 6^4$$

$$\Rightarrow \frac{n-8}{4} = \frac{1}{4} \Rightarrow n = 9$$

$$T_6 = T_{5+1} = {}^9C_5 \left(\frac{1}{2^4}\right)^4 \left(\frac{-1}{3^4}\right)^5$$

$$= \frac{{}^9C_5 \cdot 2}{3^4 \cdot 3} = \frac{84}{3^4} = \frac{\alpha}{3^4}$$

$$\Rightarrow \alpha = 84.$$

6. The number of matrices of order 3×3 , whose entries are either 0 or 1 and the sum of all the entries is a prime number, is _____.

Answer (282)

Sol. In a 3×3 order matrix there are 9 entries.

These nine entries are zero or one.

The sum of positive prime entries are 2, 3, 5 or 7.

$$\begin{aligned} \text{Total possible matrices} &= \frac{9!}{2! \cdot 7!} + \frac{9!}{3! \cdot 6!} + \frac{9!}{5! \cdot 4!} + \frac{9!}{7! \cdot 2!} \\ &= 36 + 84 + 126 + 36 \\ &= 282 \end{aligned}$$

7. Let p and $p + 2$ be prime numbers and let

$$\Delta = \begin{vmatrix} p! & (p+1)! & (p+2)! \\ (p+1)! & (p+2)! & (p+3)! \\ (p+2)! & (p+3)! & (p+4)! \end{vmatrix}$$

Then the sum of the maximum values of α and β , such that p^α and $(p + 2)^\beta$ divide Δ , is _____.

Answer (04)

$$\text{Sol. } \Delta = \begin{vmatrix} p! & (p+1)! & (p+2)! \\ (p+1)! & (p+2)! & (p+3)! \\ (p+2)! & (p+3)! & (p+4)! \end{vmatrix}$$

$$= p! \cdot (p+1)! \cdot (p+2)! \begin{vmatrix} 1 & p+1 & (p+1)(p+2) \\ 1 & (p+2) & (p+2)(p+3) \\ 1 & (p+3) & (p+3)(p+4) \end{vmatrix}$$

$$= p! \cdot (p+1)! \cdot (p+2)! \begin{vmatrix} 1 & p+1 & p^2 + 3p + 2 \\ 0 & 1 & 2p + 4 \\ 0 & 1 & 2p + 6 \end{vmatrix}$$

$$= 2(p!) \cdot ((p+1)!) \cdot ((p+2)!) \cdot$$

$$= 2(p+1) \cdot (p!)^2 \cdot ((p+2)!) \cdot$$

$$= 2(p+1)^2 \cdot (p!)^3 \cdot ((p+2)!) \cdot$$

\therefore Maximum value of α is 3 and β is 1.

$$\therefore \alpha + \beta = 4$$

8. If $\frac{1}{2 \times 3 \times 4} + \frac{1}{3 \times 4 \times 5} + \frac{1}{4 \times 5 \times 6} + \dots,$

$$+ \frac{1}{100 \times 101 \times 102} = \frac{k}{101}$$

then $34k$ is equal to _____.

Answer (286)

Sol. $S = \frac{1}{2 \times 3 \times 4} + \frac{1}{3 \times 4 \times 5} + \frac{1}{4 \times 5 \times 6}$

$$+ \dots + \frac{1}{100 \times 101 \times 102}$$

$$= \frac{1}{(3-1) \cdot 1} \left[\frac{1}{2 \times 3} - \frac{1}{101 \times 102} \right]$$

$$= \frac{1}{2} \left(\frac{1}{6} - \frac{1}{101 \times 102} \right)$$

$$= \frac{143}{102 \times 101} = \frac{k}{101}$$

$\therefore 34k = 286$

9. Let $S = \{4, 6, 9\}$ and $T = \{9, 10, 11, \dots, 1000\}$. If $A = \{a_1 + a_2 + \dots + a_k : k \in \mathbf{N}, a_1, a_2, a_3, \dots, a_k \in S\}$, then the sum of all the elements in the set $T - A$ is equal to _____.

Answer (11.00)

Sol. Here $S = \{4, 6, 9\}$

And $T = \{9, 10, 11, \dots, 1000\}$.

We have to find all numbers in the form of $4x + 6y + 9z$, where $x, y, z \in \{0, 1, 2, \dots\}$.

If a and b are coprime number then the least number from which all the number more than or equal to it can be express as $ax + by$ where $x, y \in \{0, 1, 2, \dots\}$ is $(a-1) \cdot (b-1)$.

Then for $6y + 9z = 3(2y + 3z)$

All the number from $(2-1) \cdot (3-1) = 2$ and above can be express as $2x + 3z$ (say t).

Now $4x + 6y + 9z = 4x + 3(t+2)$

$= 4x + 3t + 6$

again by same rule $4x + 3t$, all the number from $(4-1)(3-1) = 6$ and above can be express from $4x + 3t$.

Then $4x + 6y + 9z$ express all the numbers from 12 and above.

again 9 and 10 can be express in form $4x + 6y + 9z$.

Then set $A = \{9, 10, 12, 13, \dots, 1000\}$.

Then $T - A = \{11\}$

Only one element 11 is there.

Sum of elements of $T - A = 11$

10. Let the mirror image of a circle $c_1 : x^2 + y^2 - 2x - 6y + \alpha = 0$ in line $y = x + 1$ be $c_2 : 5x^2 + 5y^2 + 10gx + 10fy + 38 = 0$. If r is the radius of circle c_2 , then $\alpha + 6r^2$ is equal to _____.

Answer (12)

Sol. $c_1 : x^2 + y^2 - 2x - 6y + \alpha = 0$

Then centre = $(1, 3)$ and radius $(r) = \sqrt{10 - \alpha}$

Image of $(1, 3)$ w.r.t. line $x - y + 1 = 0$ is $(2, 2)$

$c_2 : 5x^2 + 5y^2 + 10gx + 10fy + 38 = 0$

or $x^2 + y^2 + 2gx + 2fy + \frac{38}{5} = 0$

Then $(-g, -f) = (2, 2)$

$\therefore g = f = -2 \dots(i)$

Radius of $c_2 = r = \sqrt{4 + 4 - \frac{38}{5}} = \sqrt{10 - \alpha}$

$\Rightarrow \frac{2}{5} = 10 - \alpha$

$\therefore \alpha = \frac{48}{5}$ and $r = \sqrt{\frac{2}{5}}$

$\therefore \alpha + 6r^2 = \frac{48}{5} + \frac{12}{5}$
 $= 12$

